

# ALU Accessories

Handle Globe RR

Handle Globe RR lockable/TBT

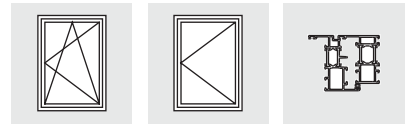

**Always** check the planning manual on aluminium (H4006.3042EN) for further details and specifications/information regarding the product and liability (guidelines: VHBH, TDBK and VHBE).

All dimensions given are final dimensions after the surface of the sections has been treated (painted, powder coated etc.).

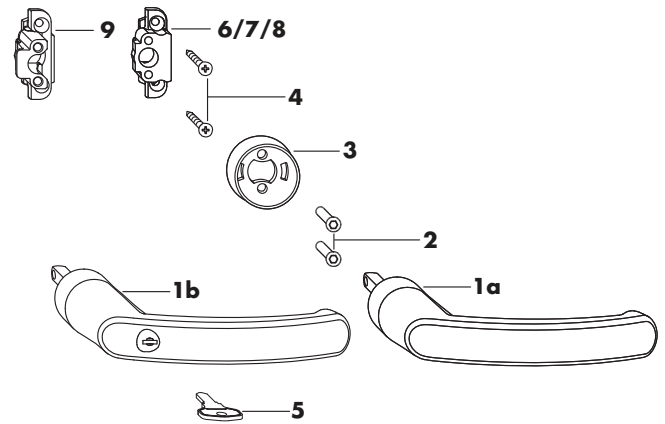

Technical specifications and colours are subject to change

Item	Quantity (smallest packaging unit)	Description		Material no.		Material no.	
	•	<b>Handle Globe RR</b>	<b>Silver</b>	1	MHGS0020-525010	10	MHGS0020-525020
			<b>White RAL 9016</b>	1	MHGS0020-504010	10	MHGS0020-504020
			<b>ESLG</b>	1	MHGS0020-800010	10	MHGS0020-800020
			<b>Mill finish</b>	1	MHGS0020-500010	10	MHGS0020-500020
	•	<b>Handle Globe RR ABS.</b>	<b>Silver</b>	1	MHGA0020-525010	10	MHGA0020-525020
			<b>White RAL 9016</b>	1	MHGA0020-504010	10	MHGA0020-504020
			<b>ESLG</b>	1	MHGA0020-800010	10	MHGA0020-800020
			<b>Mill finish</b>	1	MHGA0020-500010	10	MHGA0020-500020
1a	1	-	Handle RR				
1b	-	1	Handle RR lockable/TBT				
2	2	2	Cheese head screw				
3	1	1	Rose RR				
4	2	2	Countersunk tapping screw PH 3.9 x 13				
5	+	1	Key 2 W 145				

### Hardware depending on profile

	0...1	0...1	<b>Accessories Handle Globe RR USH-8 MM</b> (see page 2)	1	MZHG0010-100010	50	MZHG0010-100050
6	1	1	Adapter 8 mm				
	0...1	0...1	<b>Accessories Handle Globe RR USH-9 MM</b> (see page 2)	1	MZHG0020-100010	50	MZHG0020-100050
7	1	1	Adapter 9 mm				
	0...1	0...1	<b>Accessories Handle Globe RR USH10 MM</b> (see page 2)	1	MZHG0030-100010	50	MZHG0030-100050
8	1	1	Adapter 10 mm				
	0...1	0...1	<b>Accessories Handle Globe RR USH12 MM</b> (see page 2)	1	MZHG0040-100010	50	MZHG0040-100050
9	1	1	Adapter 12 mm				

### Essential Hardware

	0...1	0...1	<b>Gear set FBS M6 Trial/RR</b> (without illustration)	1	MMGI0080-100010	20	MMGI0080-100030
	0...1	0...1	<b>Gear set M6 Trial/RR</b> (without illustration)	1	MMGI0090-100010	20	MMGI0090-100030
<b>Jig</b>	-	-	<b>Disassembly device Handle RR</b> (see page 3)	1	MAEW0040-000010	10	MAEW0040-000020

### Contents

Layout of fittings, part list.....	Page 1
Sash and frame details.....	Page 2
Installation procedure.....	Page 3
Information on TBT function.....	Page 4

**Assembly instructions**  
H48.ZUBHLS006en

H48.ZUBHLS006en/1

# Handle Globe RR / Handle Globe RR lockable /TBT – Sash and frame details

Section suggestion for rebate heights 8, 9, 10 and 12 mm.

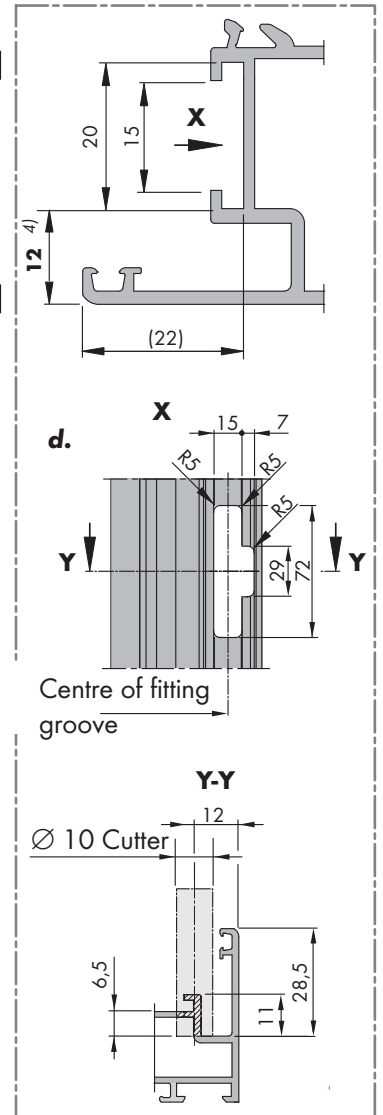
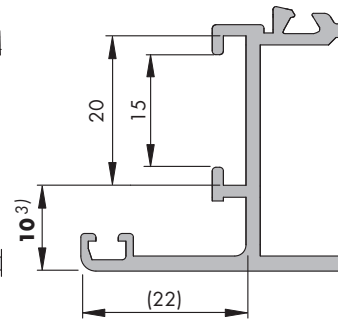
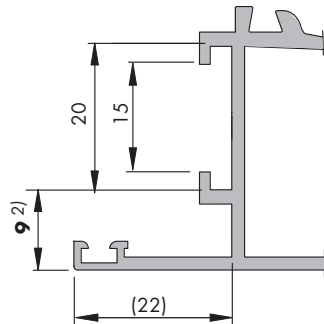
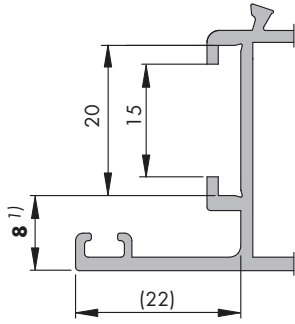

- 1) Rebate height 8 mm
- 2) Rebate height 9 mm
- 3) Rebate height 10 mm
- 4) Rebate height 12 mm

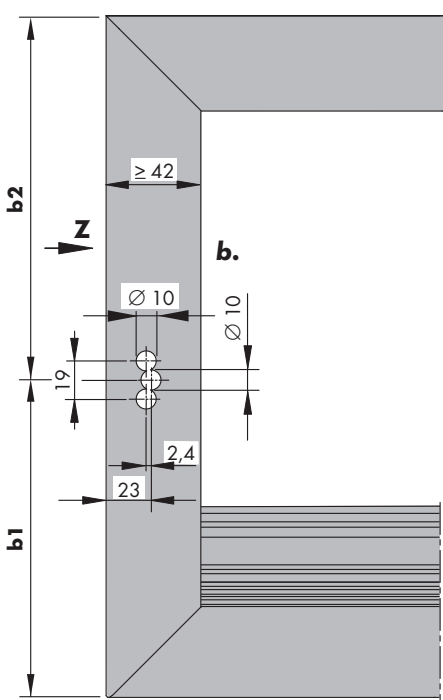

Figure 1

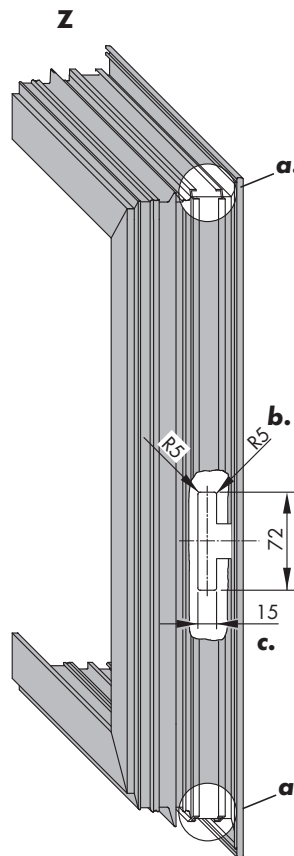

Figure 2

## Sash preparation

- a. Open operating rod guiding groove (Figure 2).
- b. Perform section processing for handle Globe RR (Figures 1+2).
- c. Processing for rebate heights 8 mm, 9 mm and 10 mm (Figure 2).
- d. Processing for rebate height 12 mm (see view X).
- e. Processing of operating rods S1 and S2 (see assembly instructions on page 1).

**Note:** A sash width of  $\geq 42$  mm is required to install the Globe RR handle and the RR Globe lockable handle.

# Handle Globe RR / Handle Globe RR lockable – Installation procedure

## Installation

**a.** Position adapter (**6/7**) on ESG LM M6/ESG LM FBS M6 (Figure 1).

**b.** Secure adapter (**6/7**) to ESG LM M6/ESG LM FBS M6 using countersunk tapping screws B3.9 x 13 (PZ 2, torque 2.5 Nm ± 0.25 Nm) (Figure 1).

**c.** Insert ESG LM M6/ESG LM FBS M6 into processed section 72 x 15 (Figure 2).

**d.** Insert operating rod S1 on the VSU and operating rod S2 on the VSO into the guiding canal (Figure 3).

**e.** Screw ESG LM M6/ESG LM FBS M6 in the operating rod punch hole  $\varnothing 5.2$  using coupling screw M6 (PZ 2, torque 2.75 Nm ± 0.25 Nm) (Figure 2).

**f.** Position rose (**3**) on the notch in the sash section as shown and tighten using cheese head screw M5 x 19 (**2**) (key dimension 2.5), torque 2.5 ± 0.25 Nm (Figure 4).

**g.** Place handle RR/handle RR lockable (**1**) on the rose as shown. Ensure that the square spindle locks into place when inserted (Figure 5).

**h.** Check that handle RR/handle RR lockable (**1**) is secure (Figure 6).

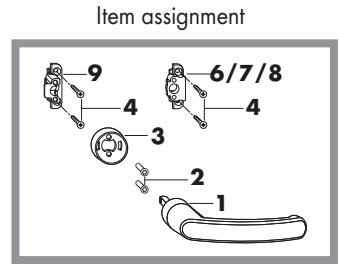
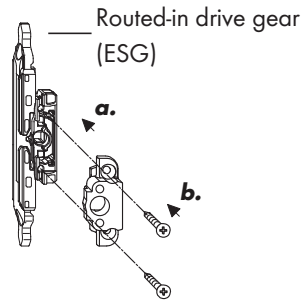

Figure 1

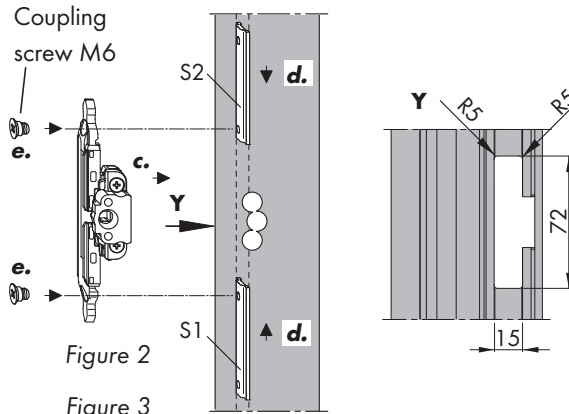

Figure 2

Figure 3

Figure 4

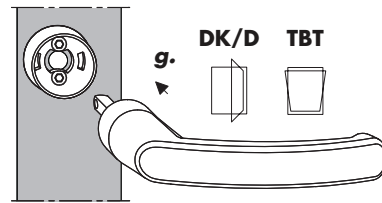
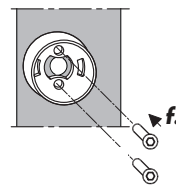

Figure 5

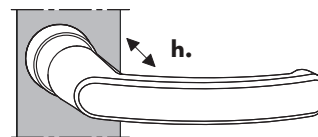

Figure 6

## Disassembly

**i.** Insert the disassembly pin into the designated opening in ESG LM M6/ ESG LM FBS M6 as shown (Figure 7).

**j.** Remove handle RR/handle RR lockable (**1**) as shown (Figure 7).

**k.** Remove disassembly pin (Figure 7).

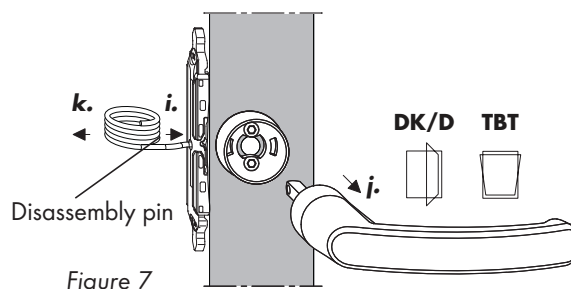
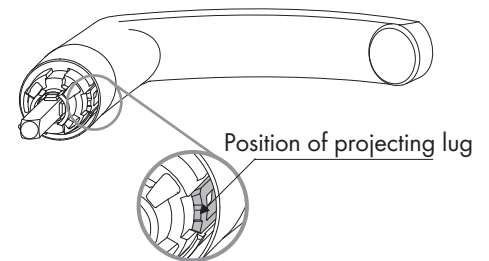

Figure 7

## Handle Globe RR lockable/TBT - Information on TBT function

### Condition of despatch:

Usage: -DK/-D right  
-DK/-D left  
-TBT right



### Modification to:

Usage: -TBT left

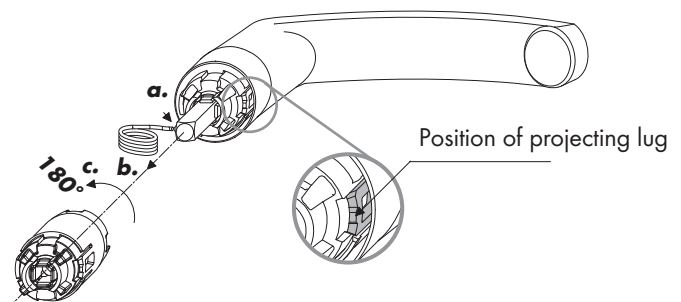

### Disassembly

- Insert the spring ball into the square spindle using the disassembly tool as shown in the figure opposite.
- Pull cylindrical insert off over the square spindle.
- Rotate cylinder by 180°.
- Position of projecting lug.

### Installation

- Slide the cylinder onto the square spindle as shown in the figure opposite.
- Handle RR lockable./TBT can now be used for TBT left application.

