

# RESTRICTOR STAYS

Designed for use with all Securistyle Domestic/Commercial hinges

Separate Restrictors can be used to provide permanent/key releasable openings.

## Applications

- Windows where a fixed opening is required
- Suitable for use with all Securistyle Domestic/Commercial hinges
- Domestic and commercial windows
- Detachable Restrictor is suitable for windows which may require periodic cleaning/maintenance

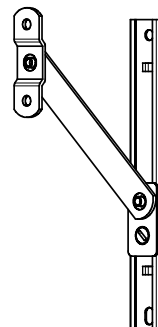

## Product features

- Options for Domestic and Commercial profiles
- Key operated detachable version for Commercial windows
- Austenitic stainless as standard on Commercial Restrictor

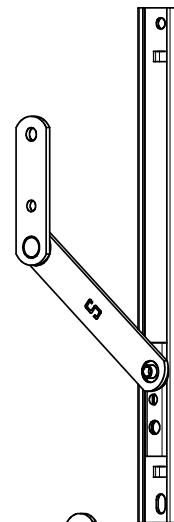

## Customer benefits

- Fixed restriction to a wide range of opening angles
- Key releasable restriction for cleaning/maintenance
- Securistyle quality and guaranteed performance

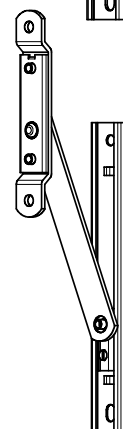

It is the responsibility of the user to ensure that this document is at the latest issue.

Due to our policy of continual product improvement we reserve the right to alter specifications without notice.

It is the responsibility of the window manufacturer to ensure that the finished window meets the required performance and safety specification.



# ANCILLARY DEVICES

RESTRICTOR STAYS

ISSUE: September, 2008

---

## CONTENTS - RESTRICTOR STAYS

---

	SECTION	SHEET
<b>Application and Selection</b>		
Application	2.1	1
Selection	2.1	1
<b>FITTING INSTRUCTIONS: Position and Clearances</b>		
Domestic Restrictor Stays	2.1	1
Commercial Restrictor Stays	2.1	2
Commercial Detachable Restrictor Stays	2.1	3
<b>FITTING INSTRUCTIONS: Vent and Frame Preparation and Fitting</b>		
Vent preparation and Fitting of Restrictor Stays	2.1	5
Frame preparation and Fitting of Restrictor Stays	2.1	6
Vent preparation and Fitting of Detachable Restrictor Stays	2.1	7
Frame preparation and Fitting of Detachable Restrictor Stays	2.1	7
<b>FITTING INSTRUCTIONS: Detachable Restrictor Stays</b>		
Detachable Restrictor Key Release	2.1	9
<b>FITTING INSTRUCTIONS: Screws</b>		
Fixing Screws	2.1	10
Fixing Rivets	2.1	12

---

It is the responsibility of the user to ensure that this document is at the latest issue.

Due to our policy of continual product improvement we reserve the right to alter specifications without notice.

It is the responsibility of the window manufacturer to ensure that the finished window meets the required performance and safety specification.

© SECURISTYLE LTD 2008



Securistyle Ltd.  
Kingsmead Industrial Estate  
Princess Elizabeth Way, Cheltenham,  
Gloucestershire, GL51 7RE  
Tel: +44 (0) 1242 221200  
Fax: +44 (0) 1242 520828  
Web: www.securistyle.co.uk

# ANCILLARY DEVICES

RESTRICTOR STAYS

ISSUE: September, 2008

---

## CONTENTS - RESTRICTOR STAYS

---

	SECTION	SHEET
<b>PERFORMANCE AND MAINTENANCE</b>		
Environmental Constraints	2.2	1
Maintenance	2.2	1
Operating Life	2.2	1
Corrosion Resistance	2.2	2
<b>PRODUCT SPECIFICATION</b>		
Product and Materials Specification	2.3	1
Standard Applicable to Restrictor Stays	2.3	1
<b>ASSEMBLY SHEETS</b>		
RS4 Restrictor Stay	2.4	1
RS6 Restrictor Stay	2.4	2
RS9 Restrictor Stay	2.4	3
SR4 Restrictor Stay	2.4	4
SR8 Restrictor Stay	2.4	5
SR16E Restrictor Stay	2.4	6
SR16BAC Restrictor Stay	2.4	7
SDR4 Detachable Restrictor Stay	2.4	8
SDR6 Detachable Restrictor Stay	2.4	9

---

It is the responsibility of the user to ensure that this document is at the latest issue.

Due to our policy of continual product improvement we reserve the right to alter specifications without notice.

It is the responsibility of the window manufacturer to ensure that the finished window meets the required performance and safety specification.

© SECURISTYLE LTD 2008



Securistyle Ltd.  
Kingsmead Industrial Estate  
Princess Elizabeth Way, Cheltenham,  
Gloucestershire, GL51 7RE  
Tel: +44 (0) 1242 221200  
Fax: +44 (0) 1242 520828  
Web: www.securistyle.co.uk

# ANCILLARY DEVICES

RESTRICTOR STAYS

ISSUE: September, 2008

---

## CONTENTS - RESTRICTOR STAYS

---

	<b>SECTION</b>	<b>SHEET</b>
SDR8 Restrictor Stay	2.4	10
SDR10 Restrictor Stay	2.4	11

---

It is the responsibility of the user to ensure that this document is at the latest issue.

Due to our policy of continual product improvement we reserve the right to alter specifications without notice.

It is the responsibility of the window manufacturer to ensure that the finished window meets the required performance and safety specification.

© SECURISTYLE LTD 2008



Securistyle Ltd.  
Kingsmead Industrial Estate  
Princess Elizabeth Way, Cheltenham,  
Gloucestershire, GL51 7RE  
Tel: +44 (0) 1242 221200  
Fax: +44 (0) 1242 520828  
Web: [www.securistyle.co.uk](http://www.securistyle.co.uk)

---

## Application and Selection - RESTRICTOR STAYS

---

### Application

#### General:

- 2.1.1 The Domestic and Commercial Restrictor Stays/Detachable Restrictor Stays\* give an opportunity to permanently restrict opening vents, particularly useful in applications where child safety is required or where windows open out onto corridors or gangways.

\*Key operated version available for cleaning/maintenance requirements of commercial windows.

#### Operation:

- 2.1.2 In normal operation the restrictor stay allows the vent to open until the slider engages against the crack stop of the track.
- 2.1.3 In normal operation the detachable restrictor stay allows the vent to open until the slider engages against the crack stop of the track, the user can then detach the restrictor through the use of a release key.

### Selection

#### General:

- 2.1.4 Designed to be fitted to the same part of the profile as the vent arm and track will suit virtually any profile that can use Securistyle Hinges.
- 2.1.5 For fixed permanent restriction: -
- Domestic Windows - **RS4**
  - **RS6**
  - **RS9**
  - Commercial Windows - **SR4**
  - **SR8**
  - **SR16**
- 2.1.6 For key releasable restriction of Commercial Windows
- **SDR4**
  - **SDR6**
  - **SDR8**
  - **SDR10**

---

It is the responsibility of the user to ensure that this document is at the latest issue.

Due to our policy of continual product improvement we reserve the right to alter specifications without notice.

It is the responsibility of the window manufacturer to ensure that the finished window meets the required performance and safety specification.



# ANCILLARY DEVICES

## FITTING INSTRUCTIONS: Position and Clearances

### Domestic Restrictor Stays

- 2.1.7 The Domestic Restrictor Stays are designed to be fitted between two flat and parallel rigid faces that conform to the measurements shown below.
- 2.1.8 The vent and outer frame location recess or up stand, if any, must be as shown in Fig. 1.

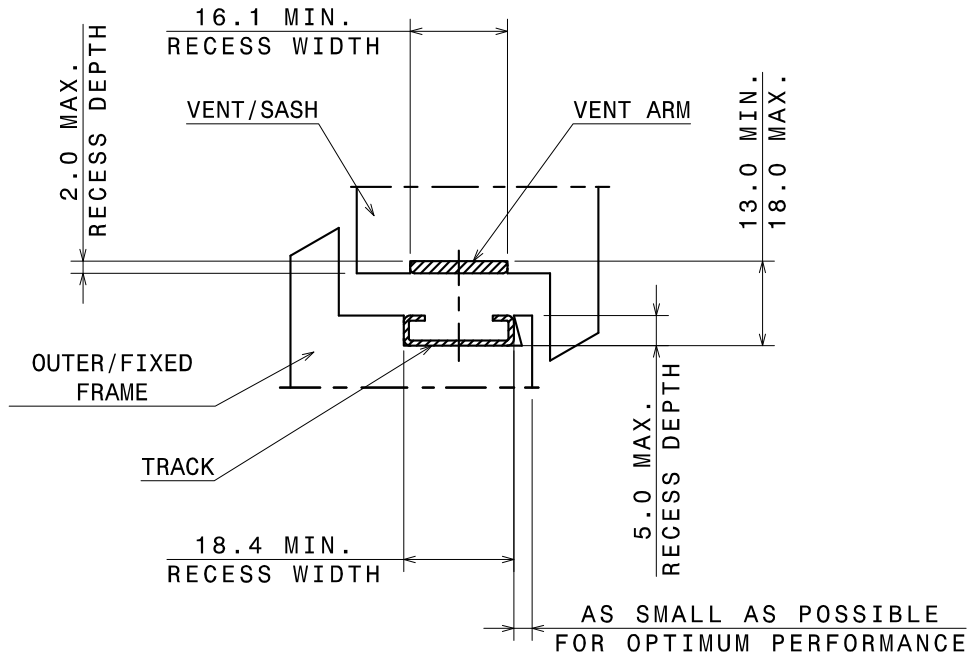

Fig. 1

**Not to Scale, All dimensions in mm**

It is the responsibility of the user to ensure that this document is at the latest issue.

Due to our policy of continual product improvement we reserve the right to alter specifications without notice.

It is the responsibility of the window manufacturer to ensure that the finished window meets the required performance and safety specification.



# ANCILLARY DEVICES

## FITTING INSTRUCTIONS: Position and Clearances

### Commercial Restrictor Stays

2.1.9 The Commercial Restrictor Stays are designed to be fitted between two flat and parallel rigid faces that conform to the measurements shown below.

2.1.10 The vent and outer frame location recess or up stand, if any, must be as shown in Fig. 2.

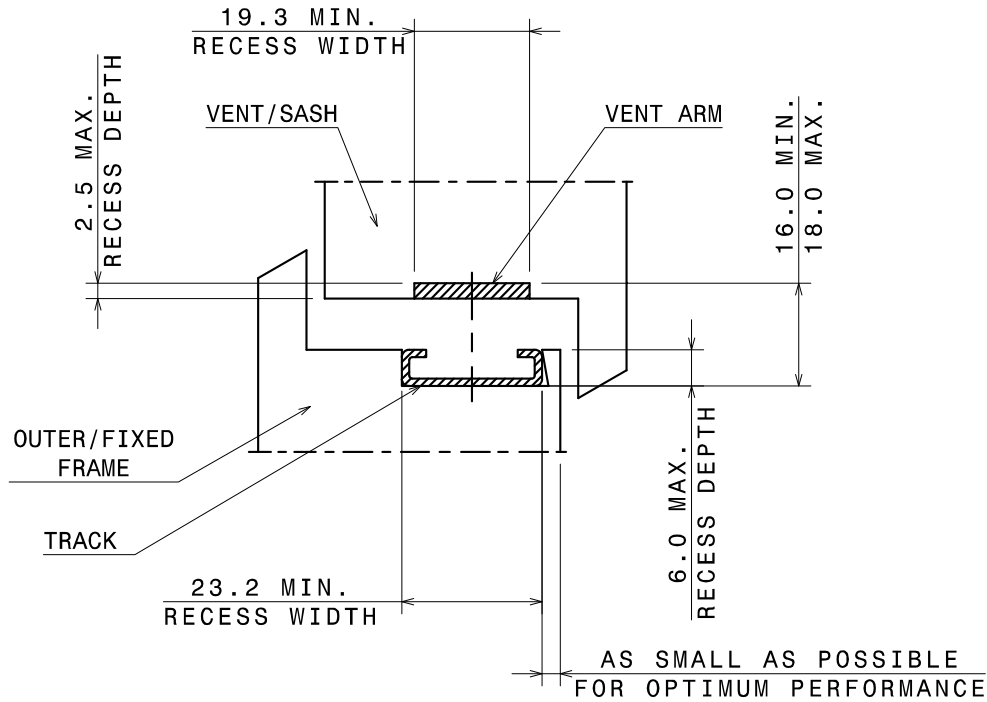

Fig. 2

**Not to Scale, All dimensions in mm**

It is the responsibility of the user to ensure that this document is at the latest issue.

Due to our policy of continual product improvement we reserve the right to alter specifications without notice.

It is the responsibility of the window manufacturer to ensure that the finished window meets the required performance and safety specification.



# ANCILLARY DEVICES

## FITTING INSTRUCTIONS: Position and Clearances

### Commercial Detachable Restrictor Stays

2.1.11 The Commercial Restrictor Stays are designed to be fitted between two flat and parallel rigid faces that conform to the measurements shown below.

2.1.12 The vent and outer frame location recess or up stand, if any, must be as shown in Fig. 3.

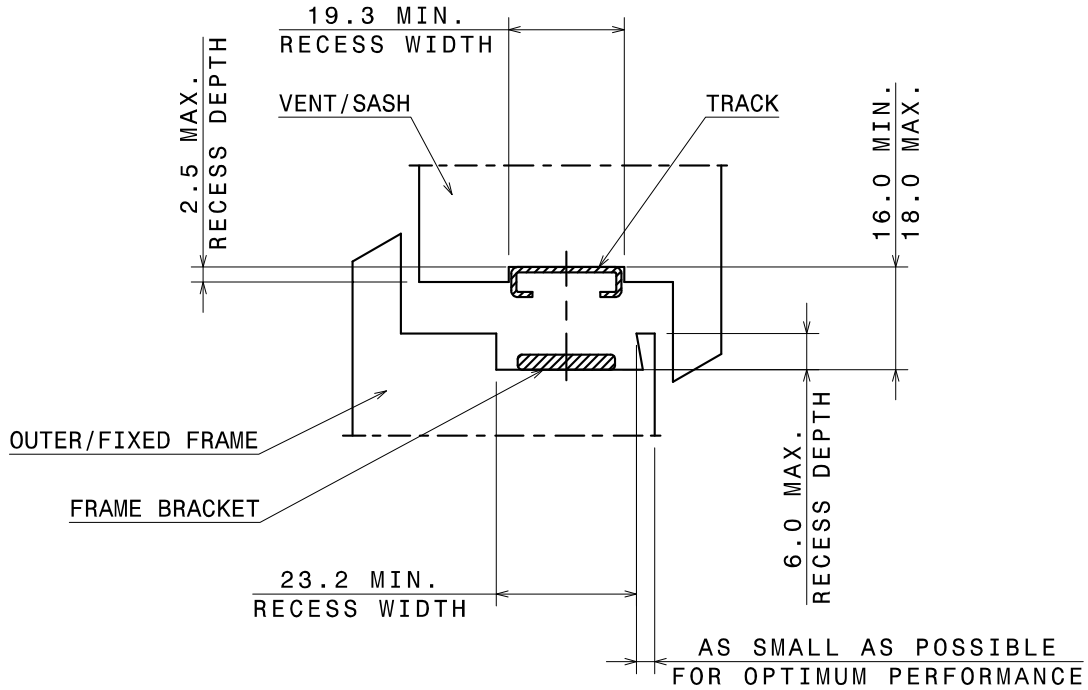

Fig. 3

**Not to Scale, All dimensions in mm**

It is the responsibility of the user to ensure that this document is at the latest issue.

Due to our policy of continual product improvement we reserve the right to alter specifications without notice.

It is the responsibility of the window manufacturer to ensure that the finished window meets the required performance and safety specification.





# ANCILLARY DEVICES

RESTRICTOR STAYS

SECTION 2.1 SHEET 5 of 12

ISSUE: September, 2008

## FITTING INSTRUCTIONS: Vent and Frame Preparation and Fitting

### Vent Preparation and Fitting of Restrictor Stays

#### Preparation:

- 2.1.13 No routing of the profile is required unless the profile silhouette does not conform to the clearances requirements (see Figs 1 and 2).

#### Fitting:

- 2.1.14 Position the Restrictor Stay Vent Bracket against any sideways hinge location features or in the hinge location channel on the vent. If the vent does not have hinge location features, determine the correct position by referring to the profile manufacturers fabrication manual and measuring/markings, ('Fitting Instructions: Positions and Clearances' will help).

**Note:** The closer the Restrictor Stay is positioned to the hinge the greater the opening angle of the vent will be, subsequently the further away the Vent Bracket is positioned from the hinge the smaller the opening angle of the vent will be. See Fig. 4

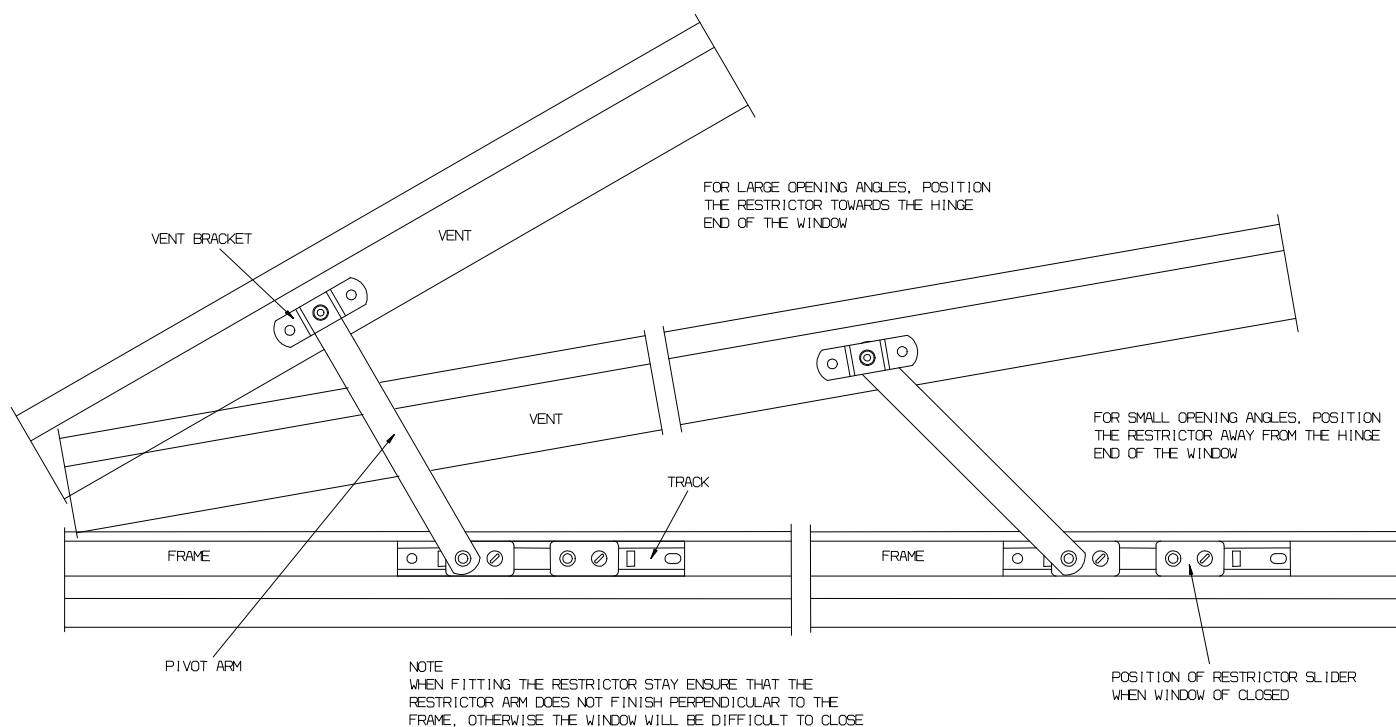

Fig. 4

#### Fixing:

- 2.1.15 Insert fixings through the holes in the Vent Bracket once you are satisfied with its position. If possible pick up on any screw location ports\* and/or reinforcement.

It is the responsibility of the user to ensure that this document is at the latest issue.

Due to our policy of continual product improvement we reserve the right to alter specifications without notice.

It is the responsibility of the window manufacturer to ensure that the finished window meets the required performance and safety specification.

© SECURISTYLE LTD 2008



Securistyle Ltd.  
Kingsmead Industrial Estate  
Princess Elizabeth Way, Cheltenham,  
Gloucestershire, GL51 7RE  
Tel: +44 (0) 1242 221200  
Fax: +44 (0) 1242 520828  
Web: www.securistyle.co.uk

# ANCILLARY DEVICES

## FITTING INSTRUCTIONS: Vent and Frame Preparation and Fitting

### Frame Preparation and Fitting of Restrictor Stays

#### Preparation:

- 2.1.16 No routing of the profile is required unless the profile silhouette does not conform to the clearances requirements (See Figs. 1 and 2).

#### Fitting:

- 2.1.17 Position the Restrictor Stay track with the stay in its open position against any sideways hinge location features or in the hinge location channel on the frame, commonly the glazing bar clip channel. See Fig. 5

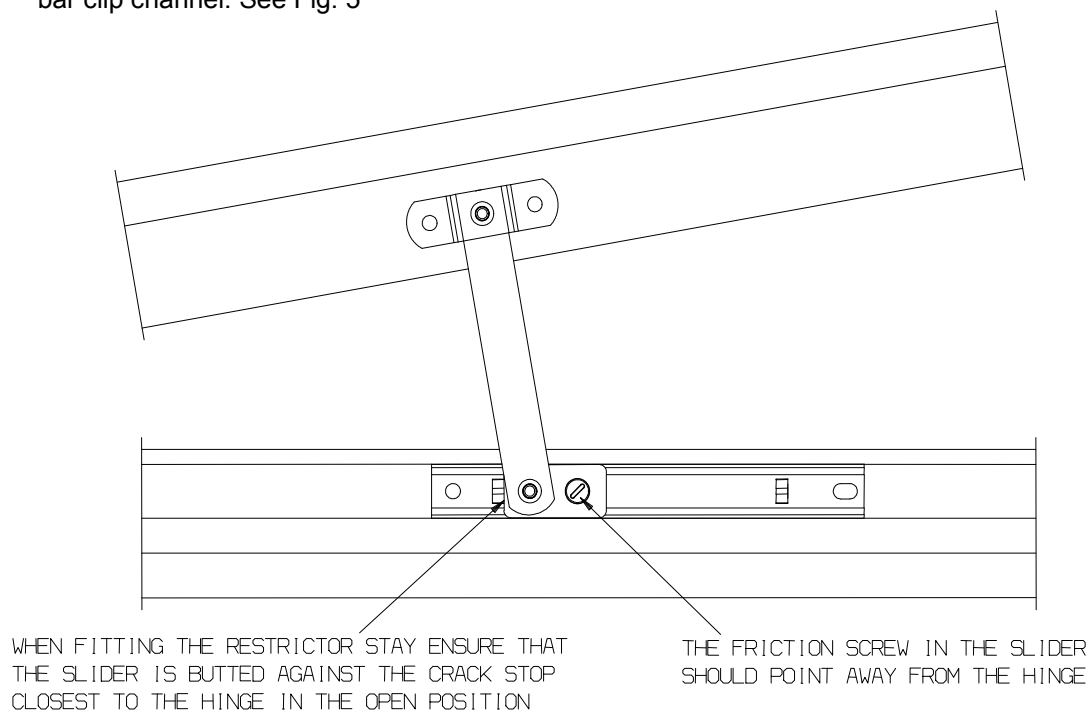

Fig. 5

#### Fixing:

- 2.1.18 Insert fixings through the slot/slots in the track in the track once you are satisfied with its position, insert the final fixing into the fixing hole/holes. If possible pick up on any screw location ports\* and/or reinforcement.

\*Certain profiles incorporate a groove to assist with screw positioning/insertion.

For screw specification refer to subsequent section.

It is the responsibility of the user to ensure that this document is at the latest issue.

Due to our policy of continual product improvement we reserve the right to alter specifications without notice.

It is the responsibility of the window manufacturer to ensure that the finished window meets the required performance and safety specification.

# ANCILLARY DEVICES

RESTRICTOR STAYS

SECTION 2.1 SHEET 7 of 12

ISSUE: September, 2008

## FITTING INSTRUCTIONS: Vent and Frame Preparation and Fitting

---

### Vent Preparation and Fitting of Detachable Restrictor Stays

#### Preparation:

- 2.1.19 No routing of the profile is required unless the profile silhouette does not conform to the clearances requirements (see Fig. 3).

#### Fitting:

- 2.1.20 Position the Restrictor Stay track inline with the hinge vent arm, parallel with any sideways hinge location features or in the hinge location channel on the frame, commonly the glazing bar clip channel.

#### Fixing:

- 2.1.21 Insert fixings through the slot/slots in the track in the track once you are satisfied with its position then insert the final fixing into the fixing hole/holes. If possible pick up on any screw location ports\* and/or reinforcement.

### Frame Preparation and Fitting of Restrictor Stays

#### Preparation:

- 2.1.22 No routing of the profile is required unless the profile silhouette does not conform to the clearances requirements. See Fig. 3.

#### Fitting:

- 2.1.23 Position the Restrictor Stay Frame Bracket inline with the track of the hinge, parallel with any sideways hinge location features or in the hinge location channel on the vent ensuring that the Vent Bracket is orientated so that the keyway is pointing away from the hinge. See Fig. 6. If the vent does not have hinge location features, determine the correct position by referring to the profile manufacturers fabrication manual and measuring/markings, ('Fitting Instructions: Positions and Clearances' will help).

**Note:** The closer the Detachable Restrictor Stay is positioned to the hinge the greater the opening angle of the vent will be, subsequently the further away the Vent Bracket is positioned from the hinge the smaller the opening angle of the vent will be. (As Fig. 4 but with the Vent Bracket attached to the Frame and the Track attached to the Vent).

---

It is the responsibility of the user to ensure that this document is at the latest issue.

Due to our policy of continual product improvement we reserve the right to alter specifications without notice.

It is the responsibility of the window manufacturer to ensure that the finished window meets the required performance and safety specification.

© SECURISTYLE LTD 2008



Securistyle Ltd.  
Kingsmead Industrial Estate  
Princess Elizabeth Way, Cheltenham,  
Gloucestershire, GL51 7RE  
Tel: +44 (0) 1242 221200  
Fax: +44 (0) 1242 520828  
Web: www.securistyle.co.uk

# ANCILLARY DEVICES

## FITTING INSTRUCTIONS: Vent and Frame Preparation and Fitting

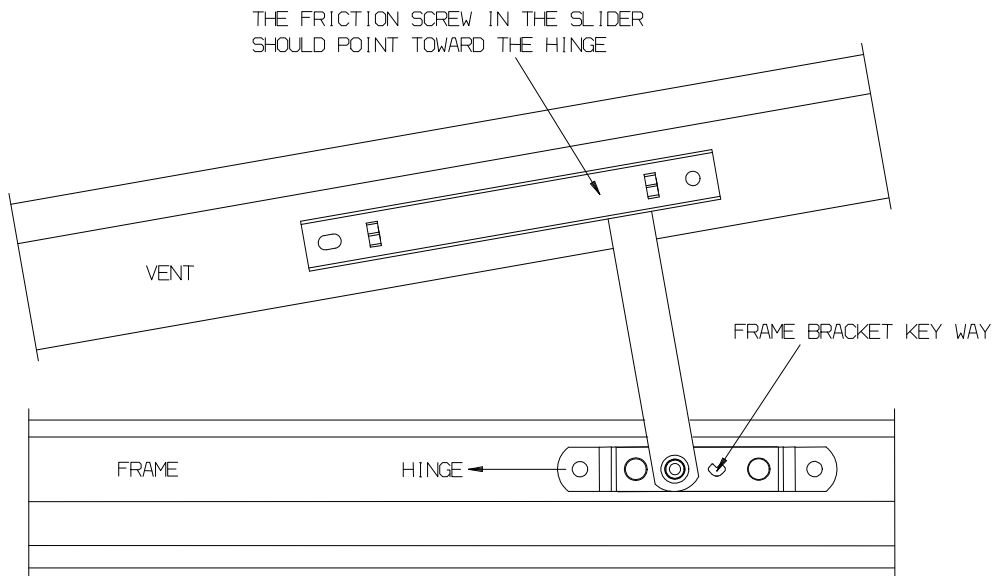

Fig. 6

### Fixing:

2.1.24 Insert fixings through the holes in the Frame Bracket once you are satisfied with its position. If possible pick up on any screw location ports\* and/or reinforcement.

\*Certain profiles incorporate a groove to assist with screw positioning/insertion.

For screw specification refer to subsequent section.

It is the responsibility of the user to ensure that this document is at the latest issue.

Due to our policy of continual product improvement we reserve the right to alter specifications without notice.

It is the responsibility of the window manufacturer to ensure that the finished window meets the required performance and safety specification.

# ANCILLARY DEVICES

## FITTING INSTRUCTIONS: Detachable Restrictor Stays

### Detachable Restrictor Key Release

#### Operation

- 2.1.25 In order to release the Detachable Restrictor Pivot Arm from the Frame Bracket the user must insert the Release Key into the Key Way of the Frame Bracket and rotate it in a clockwise direction through 90°. See Fig. 7.

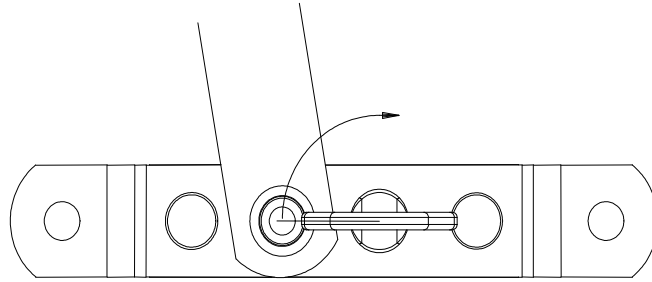

Fig. 7

- 2.1.26 The user then detaches the Pivot Arm clear from the Frame Bracket. See Fig. 8.

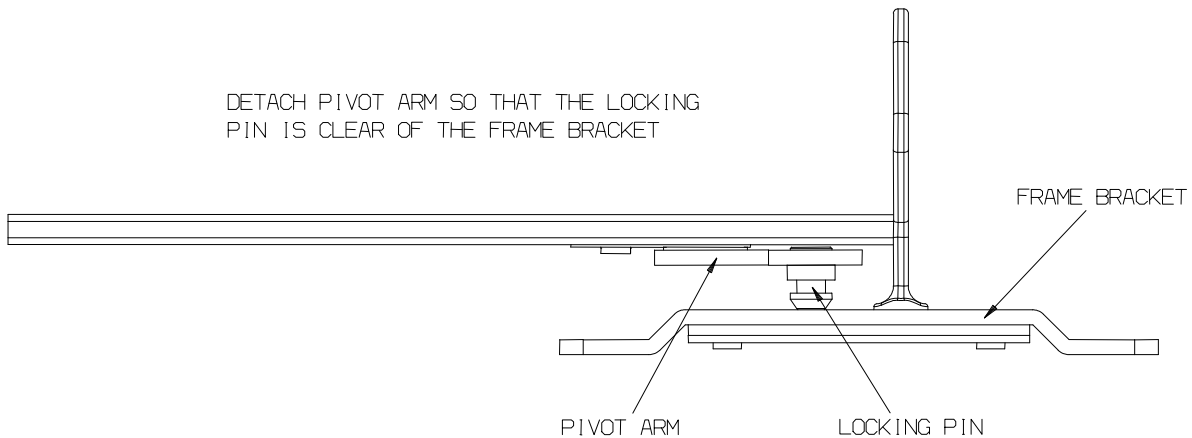

Fig. 8

It is the responsibility of the user to ensure that this document is at the latest issue.

Due to our policy of continual product improvement we reserve the right to alter specifications without notice.

It is the responsibility of the window manufacturer to ensure that the finished window meets the required performance and safety specification.

# ANCILLARY DEVICES

## FITTING INSTRUCTIONS: Screws and Rivets

### Fixing Screws

2.1.27 On the following Restrictor Stays the fixings specified should be used: -

2.1.27.1 **Domestic Restrictor Stays** - Use No. 8 fixing screws or specialist equivalent e.g. special threads for PVCu.

2.1.28 The following constraints should be strictly adhered to:-

2.1.28.1 Pan or mushroom head screws are the preferred option. See Fig. 5

2.1.28.2 Countersunk heads are acceptable but will not produce a neat appearance. See Fig. 5

2.1.28.3 Screws with countersunk/pan heads are also an acceptable head format. See Fig. 5

2.1.28.4 Screw manufacturers recommended pilot hole sizes must be adhered to at all times and if any instructions are supplied by window system manufacturers/suppliers, such as "screw into reinforcement", it is important that they are followed.

2.1.28.5 When fitting Restrictor Stays extreme care must be taken not to strip the thread as deterioration in performance will result.

2.1.28.6 It has been shown that Austenitic fixings provide superior corrosion resistance when subject to BS 7479.

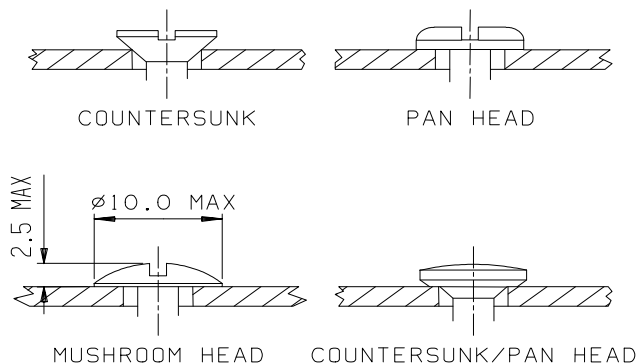

Fig. 6

**Note:** It is the responsibility of the window manufacturer to ensure that all fixing screws and rivets have adequate strength to support the weight of the window vent and the forces exerted upon it over the full life of the window.

**Not to Scale, All dimensions in mm**

It is the responsibility of the user to ensure that this document is at the latest issue.

Due to our policy of continual product improvement we reserve the right to alter specifications without notice.

It is the responsibility of the window manufacturer to ensure that the finished window meets the required performance and safety specification.

# ANCILLARY DEVICES

## FITTING INSTRUCTIONS: Screws and Rivets

### Fixing Screws

2.1.29 On the following Restrictor Stays the fixings specified should be used: -

2.1.29.1 **Commercial Restrictor Stays/Commercial Detachable Restrictor Stays** - Use No.10 self tapping screws or M5 screws and M5 Rivnuts or a specialist equivalent i.e. with special threads for PVCu.

2.1.30 The following constraints should be strictly adhered to:-

2.1.30.1 Pan, mushroom or standard dome head screws are the preferred option.

2.1.30.2 Countersunk heads are acceptable but will not produce a neat appearance.

2.1.30.3 Screws with special combination countersunk/pan heads are also an acceptable head format. See Fig. 6 below.

2.1.30.4 Screw manufacturers recommended pilot hole sizes must be adhered to at all times and if any instructions are supplied by window system manufacturers/suppliers, such as "screw into reinforcement", it is important that they are followed.

2.1.30.5 When fitting Restrictor Stays extreme care must be taken not to strip the thread as deterioration in performance will result.

2.1.30.6 It has been shown that Austenitic and certain types of Modified Martensitic fixings provide superior corrosion resistance when subject to BS 7479.

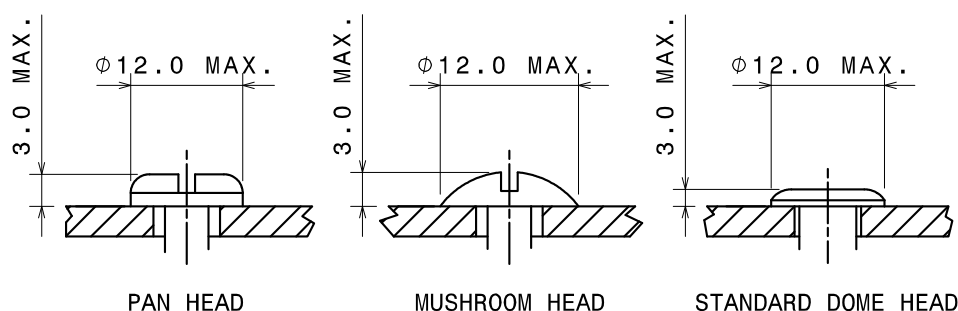

Fig. 7

**Note:** It is the responsibility of the window manufacturer to ensure that all fixing screws and rivets have adequate strength to support the weight of the window vent and the forces exerted upon it over the full life of the window.

**Not to Scale, All dimensions in inches & mm**

It is the responsibility of the user to ensure that this document is at the latest issue.

Due to our policy of continual product improvement we reserve the right to alter specifications without notice.

It is the responsibility of the window manufacturer to ensure that the finished window meets the required performance and safety specification.

# ANCILLARY DEVICES

## FITTING INSTRUCTIONS: Screws and Rivets

### Fixing Rivets

2.1.31 Fixing rivets (pop and peel blind rivets) should be 5mm or 3/16 inch diameter and of a length to suit the total riveting thickness as recommended by the rivet manufacturer. The following additional constraints must be adhered to:-

2.1.31.1 Head maximum sizes must not exceed those shown below.

2.1.31.2 All rivet manufacturers recommendations must be observed.

2.1.31.3 Only stainless steel rivets are recommended for use by SECURISTYLE® Ltd.

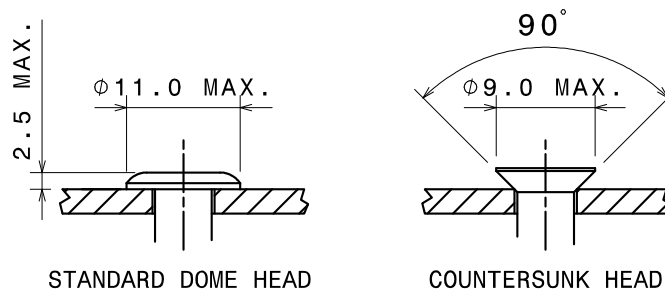

Fig. 8

**Note:** It is the responsibility of the window manufacturer to ensure that all fixing screws and rivets have adequate strength to support the weight of the window vent and the forces exerted upon it over the full life of the window.

**Not to Scale, All dimensions in inches & mm**

It is the responsibility of the user to ensure that this document is at the latest issue.

Due to our policy of continual product improvement we reserve the right to alter specifications without notice.

It is the responsibility of the window manufacturer to ensure that the finished window meets the required performance and safety specification.



# ANCILLARY DEVICES

## PERFORMANCE AND MAINTENANCE

---

### Environmental Constraints

- 2.2.1 Normal operating conditions for all hinges are:
- 2.2.1.1 Operating temperature range -20°C to +60°C
  - 2.2.1.2 Operating humidity range 10% Relative Humidity to 95% Relative Humidity
- 2.2.2 The materials used will not degrade due to ultra violet light, or when using neutral acidity non solvent cleaning chemicals, at a rate faster than other parts of the window assembly. However, the practice of cleaning brickwork with acidic based products will have serious effects if allowed to come into contact with hardware. Corrosion or failure of hardware as a result of this practice will not be covered by the warranty issued on such products. For further advice on procedures for protecting the window during this operation, please contact the window manufacturer or hardware supplier.

### Maintenance and Lubrication

- 2.2.3 As with most mechanical devices, Restrictor Stays require periodic maintenance and lubrication. The hinge in general and particularly the pivots, sliding shoe and track must be kept free from dirt, debris and any obstructions at all times.
- 2.2.3.1 **At Time of Installation** - Lubricate all pivot points with light machine oil and wipe away excess, one drop per pivot is sufficient. We suggest one of the following lubricants or equivalent:
- a. General light engineering oil with corrosion inhibitors such as Castrol Everyman or 3 in 1 oil (available in aerosol can for convenience).
- Note:** Solvent based aerosol sprays e.g. WD40 are not suitable for this application.
- 2.2.3.2 **Every Five Years** - Carry out the following checks every five years:
- a. Clean any dirt or debris from the hinge and clear any obstructions from the pivots, sliding shoe and track.
  - b. Apply lubrication as detailed in 2.2.4.1 above.
  - c. Check the tightness and security of all fixing screws and rivets.

### Operating Life

- 2.2.4 To attain optimum operating life all criteria listed above under; environmental constraints, and maintenance and lubrication must be adhered to.
- 2.2.5 All Restrictor Stays will function normally for up to 30,000 cycles under normal conditions of use. This performance is subject to compliance with SECURISTYLE® installation and maintenance instructions.

---

It is the responsibility of the user to ensure that this document is at the latest issue.

Due to our policy of continual product improvement we reserve the right to alter specifications without notice.

It is the responsibility of the window manufacturer to ensure that the finished window meets the required performance and safety specification.



# ANCILLARY DEVICES

## PERFORMANCE AND MAINTENANCE

---

### Corrosion Resistance

- 2.2.6 When subjected to neutral salt spray test to BS 7479: 1991 / ISO 9227: 1990 the hinge remains functional. There is no significant surface pitting caused by corrosion. Some surface discolouration is to be expected.
- 2.2.7 If a hinge is fitted in an area where it is exposed to a corrosive atmosphere, e.g. salt laden sea air in coastal locations, we recommended that in addition to the general maintenance and lubrication:
- 2.2.7.1 All metal surfaces are lightly coated with lubrication oil or sprayed with a proprietary anticorrosion spray. It is important to follow the manufacturer's instructions for any products used.
  - 2.2.7.2 Maintenance operations may need to be carried out more frequently. This is dependent on the severity of the prevailing conditions.

---

It is the responsibility of the user to ensure that this document is at the latest issue.

Due to our policy of continual product improvement we reserve the right to alter specifications without notice.

It is the responsibility of the window manufacturer to ensure that the finished window meets the required performance and safety specification.



---

## PRODUCT SPECIFICATION

---

### Product and Materials Specification

2.3.1 The following is a guide to the materials used for Domestic and Commercial Restrictor Stays.

2.3.1.1 **Surface Finish** - All surface finishes are of good commercial quality.

- 2mm & 2.5mm stainless steel components (links) are of cold rolled finish and are edge dressed to remove the sharp edges as far as is practical.
- 0.9mm stainless steel components (track) are of bright cold rolled finish.
- 1.22mm stainless steel components (track) are of bright cold rolled finish.
- Stainless steel components will not display surface blemishes, pits or scratches of greater than 20 sq. mm or 0.25mm maximum depth.
- Plastic components are of uniform finish and colour. Visible surfaces will not display blemishes, pits or scratches of greater than 15 sq. mm or 0.2mm maximum depth.
- Die cast components are of uniform finish. Visible surfaces will not display blemishes, pits or scratches of greater than 15 sq. mm or 0.2mm maximum depth.

### Standards Applicable for Restrictor Stays

2.3.2 The relevant standards applicable are:

2.3.2.1 **Ferritic Stainless Steel**

Links	-	Stainless steel to BS EN ISO 10088/2 GRADE 1.4016: 1995
Track	-	Stainless steel to BS EN ISO 10088/2 GRADE 1.4016: 1995

2.3.2.2 **Austenitic Stainless Steel**

Links	-	Stainless steel to BS EN ISO 10088/2 GRADE 1.4301: 1995
Track	-	Stainless steel to BS EN ISO 10088/2 GRADE 1.4301: 1995
Pivot Rivets	-	Stainless steel to BS EN ISO 10263/5 GRADE 1.4567: 2001

---

It is the responsibility of the user to ensure that this document is at the latest issue.

Due to our policy of continual product improvement we reserve the right to alter specifications without notice.

It is the responsibility of the window manufacturer to ensure that the finished window meets the required performance and safety specification.



# ANCILLARY DEVICES

---

## PRODUCT SPECIFICATION

---

### 2.3.3 Other Materials for Domestic and Sterling Commercial Restrictor Stays.

Slider (DEFENDER® Restrictor Stays only)	-	Grey Acetal Homopolymer or Acetal Copolymer
Slider Inner (STERLING®, Sterling STORM® Restrictor Stays only)	-	Stainless Steel to BS EN ISO 10088/2 GRADE 1.4301: 1995
Slider Outer (STERLING® Restrictor Stays only)	-	Black Acetal Homopolymer or Acetal Copolymer
Slider Outer (Sterling STORM® Restrictor Stays only)	-	13% Glass Filled Nylon
Friction Cam (DEFENDER® Restrictor Stays only)	-	Zinc Alloy plated with Zinc and Gold Passivate
Friction Screw (STERLING®, Sterling STORM® Restrictor Stays only)	-	Austenitic Stainless steel to BS 6105 Grade A1-50
Pivot Washer	-	Natural (Translucent) Nylon

### 2.3.4 Link and Track Dimensions

Link thickness	-	1.96mm to 2.1mm
	-	2.39mm to 2.61mm
Link width	-	15.9mm to 16.1mm
	-	18.85mm to 19.05mm
Track rolled section height	-	4.79mm to 5.23mm
	-	5.80mm to 6.00mm
Track rolled section width	-	18.02mm to 18.36mm
	-	22.9mm to 23.2mm

**Note:** Component descriptions which have ( ) under them, indicate that the component is only used on the stated hinge range/assembly. Those which do not indicate that the component is used on Domestic and Commercial restrictor stays.

---

It is the responsibility of the user to ensure that this document is at the latest issue.

Due to our policy of continual product improvement we reserve the right to alter specifications without notice.

It is the responsibility of the window manufacturer to ensure that the finished window meets the required performance and safety specification.



---

## PRODUCT SPECIFICATION

---

### 2.3.5 Testing Standards

2.3.5.1 BS 6375 : Part 2 : 1987. Section 5 Testing. Ref. appendix A (A.7 Test 6).

2.3.5.2 BS 8213 : Part 1 : 1991. Section 2. Safety in use. Point 5.1.2.

---

It is the responsibility of the user to ensure that this document is at the latest issue.

Due to our policy of continual product improvement we reserve the right to alter specifications without notice.

It is the responsibility of the window manufacturer to ensure that the finished window meets the required performance and safety specification.



# ANCILLARY DEVICES

## ASSEMBLY SHEET - RS4

### Restrictor Stay

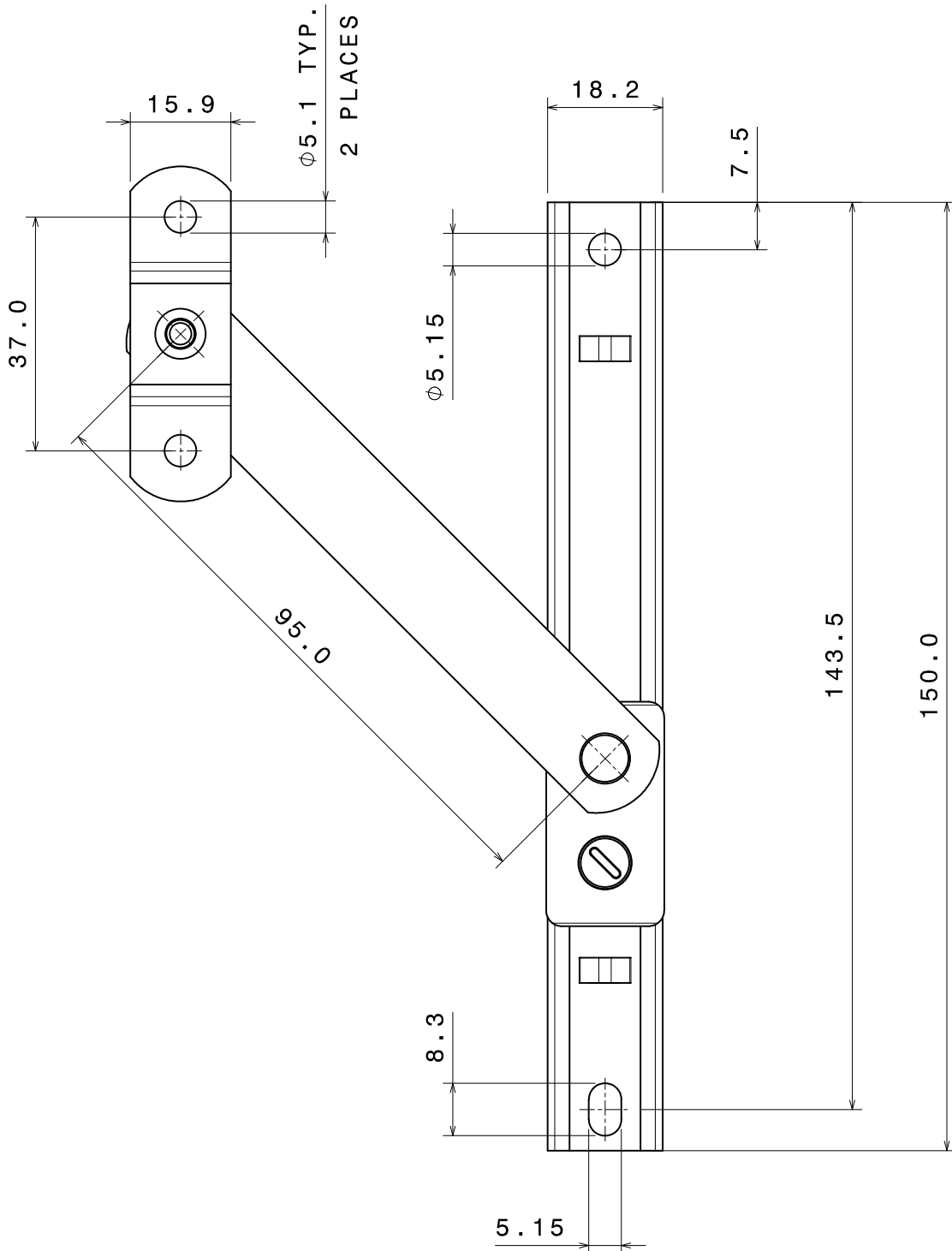

**Not to Scale, All dimensions in mm**

It is the responsibility of the user to ensure that this document is at the latest issue.

Due to our policy of continual product improvement we reserve the right to alter specifications without notice.

It is the responsibility of the window manufacturer to ensure that the finished window meets the required performance and safety specification.



# ANCILLARY DEVICES

## ASSEMBLY SHEET - RS6

### Restrictor Stay

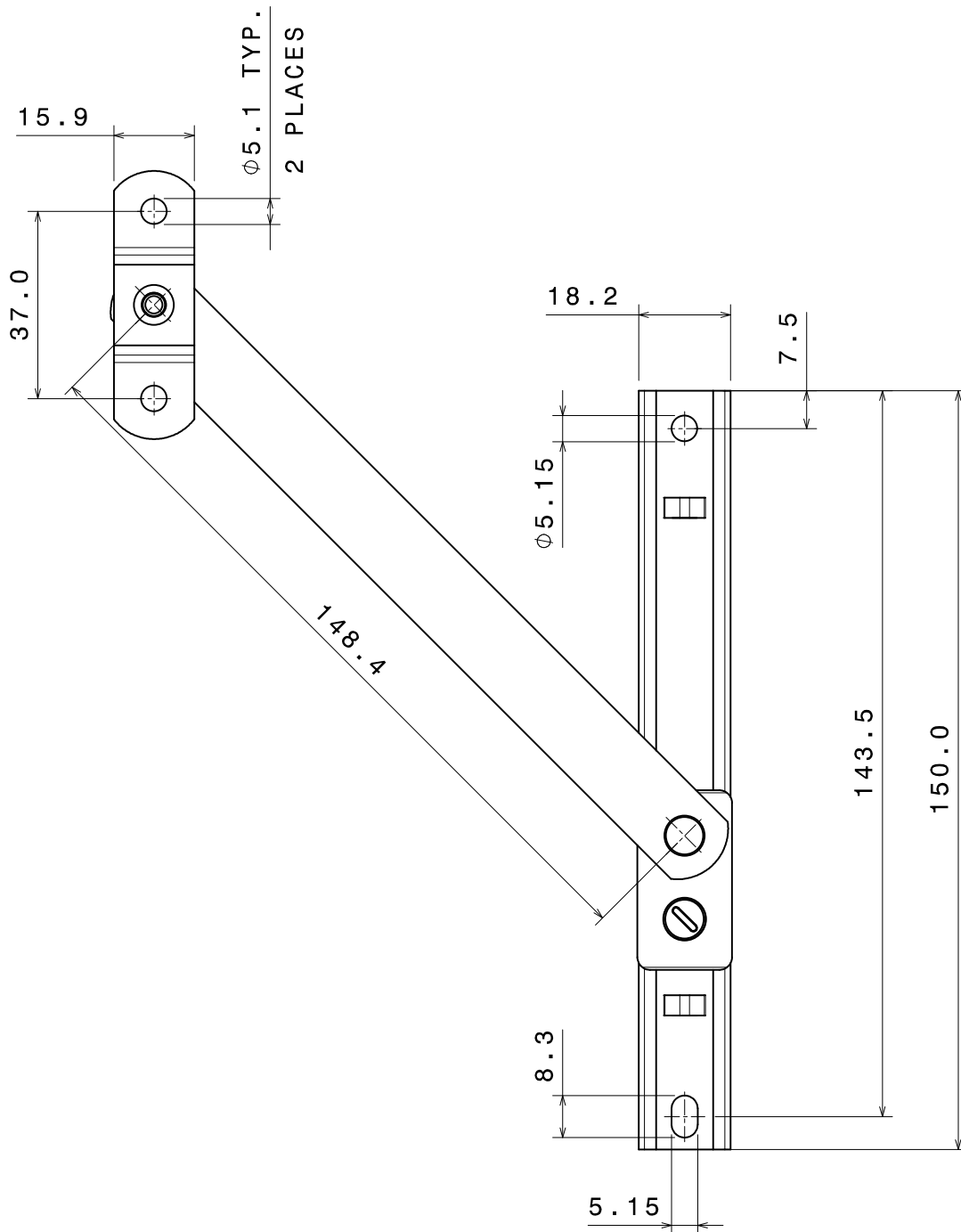

**Not to Scale, All dimensions in mm**

It is the responsibility of the user to ensure that this document is at the latest issue.

Due to our policy of continual product improvement we reserve the right to alter specifications without notice.

It is the responsibility of the window manufacturer to ensure that the finished window meets the required performance and safety specification.



# ANCILLARY DEVICES

RESTRICTOR STAYS

SECTION 2.4 SHEET 3 of 11

ISSUE: September, 2008

## ASSEMBLY SHEET - RS9

### Restrictor Stay

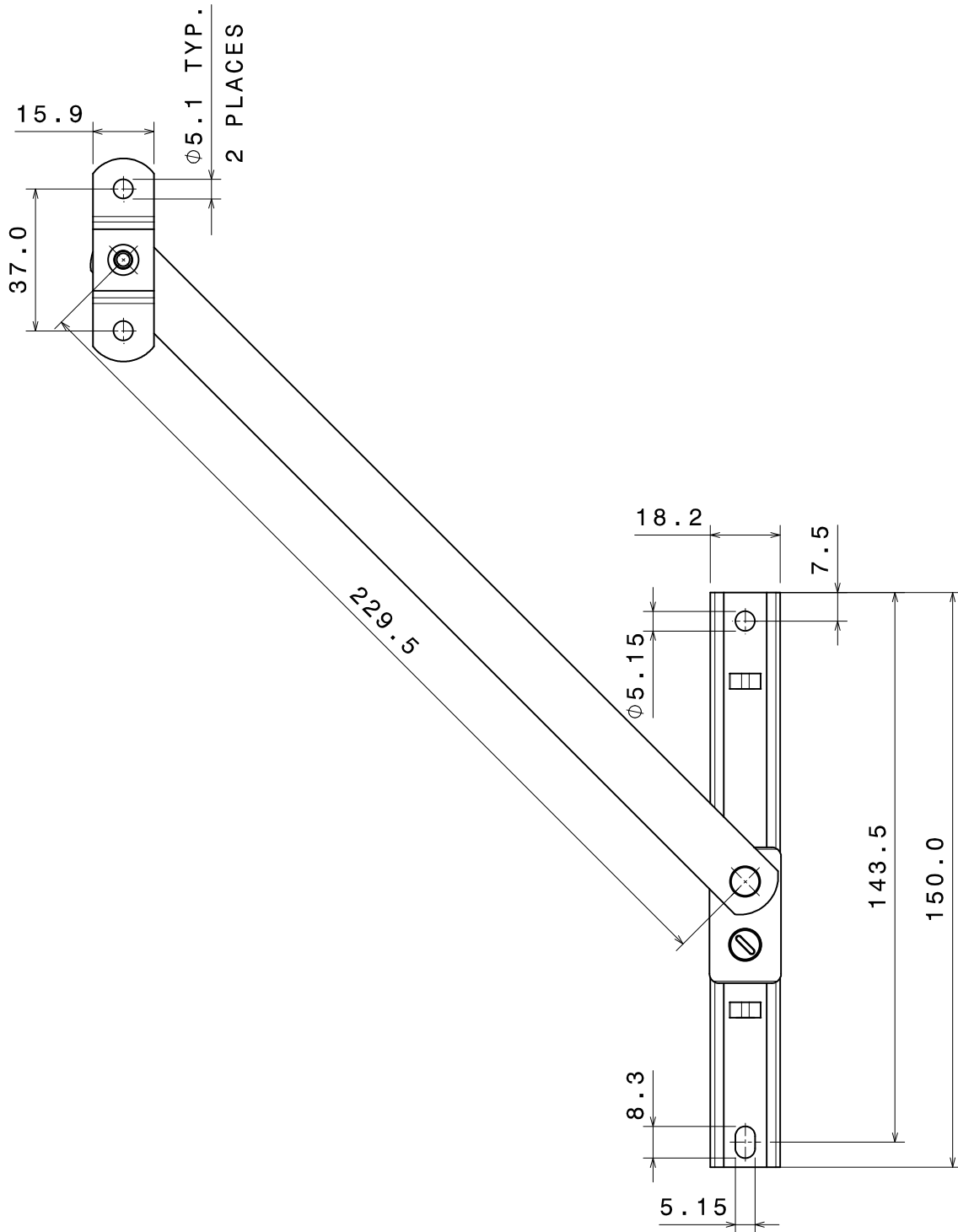

**Not to Scale, All dimensions in mm**

It is the responsibility of the user to ensure that this document is at the latest issue.

Due to our policy of continual product improvement we reserve the right to alter specifications without notice.

It is the responsibility of the window manufacturer to ensure that the finished window meets the required performance and safety specification.

© SECURISTYLE LTD 2008



Securistyle Ltd.  
Kingsmead Industrial Estate  
Princess Elizabeth Way, Cheltenham,  
Gloucestershire, GL51 7RE  
Tel: +44 (0) 1242 221200  
Fax: +44 (0) 1242 520828  
Web: www.securistyle.co.uk



# ANCILLARY DEVICES

## ASSEMBLY SHEET - SR4

### Restrictor Stay

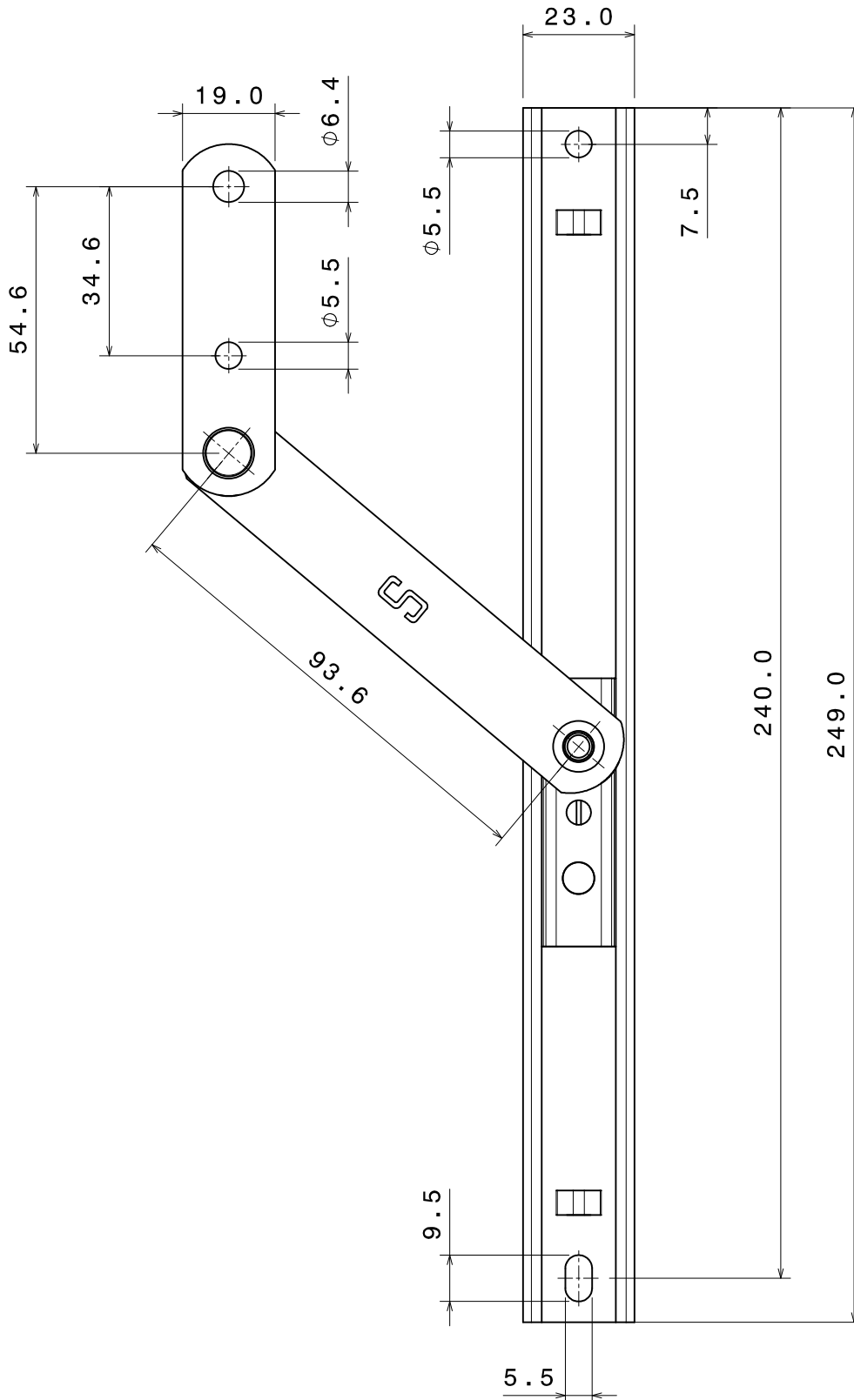

**Not to Scale, All dimensions in inches & mm**

It is the responsibility of the user to ensure that this document is at the latest issue.

Due to our policy of continual product improvement we reserve the right to alter specifications without notice.

It is the responsibility of the window manufacturer to ensure that the finished window meets the required performance and safety specification.



# ANCILLARY DEVICES

## ASSEMBLY SHEET - SR8 Restrictor Stay

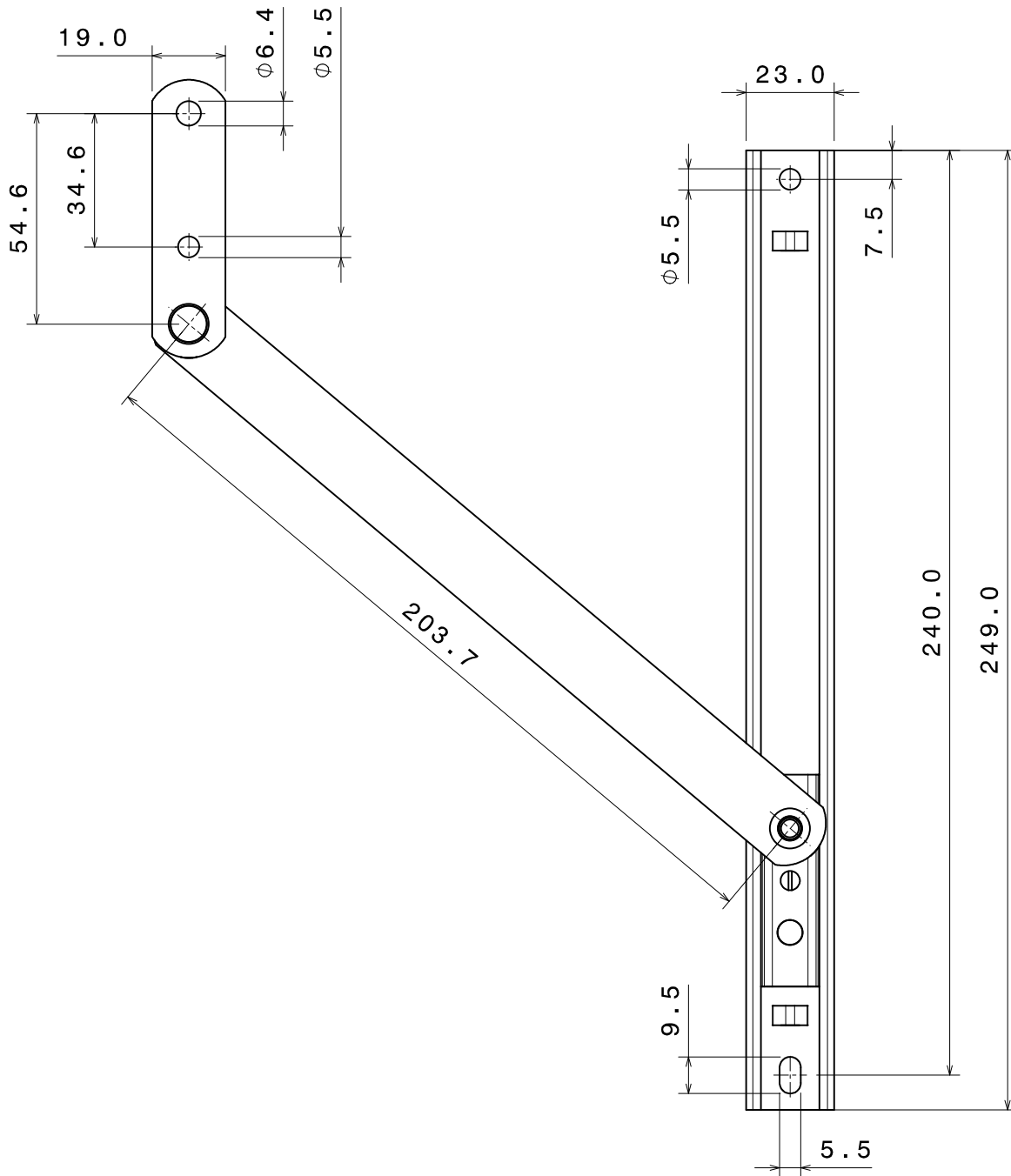

**Not to Scale, All dimensions in inches & mm**

It is the responsibility of the user to ensure that this document is at the latest issue.

Due to our policy of continual product improvement we reserve the right to alter specifications without notice.

It is the responsibility of the window manufacturer to ensure that the finished window meets the required performance and safety specification.



# ANCILLARY DEVICES

## ASSEMBLY SHEET - SR16E

### Restrictor Stay

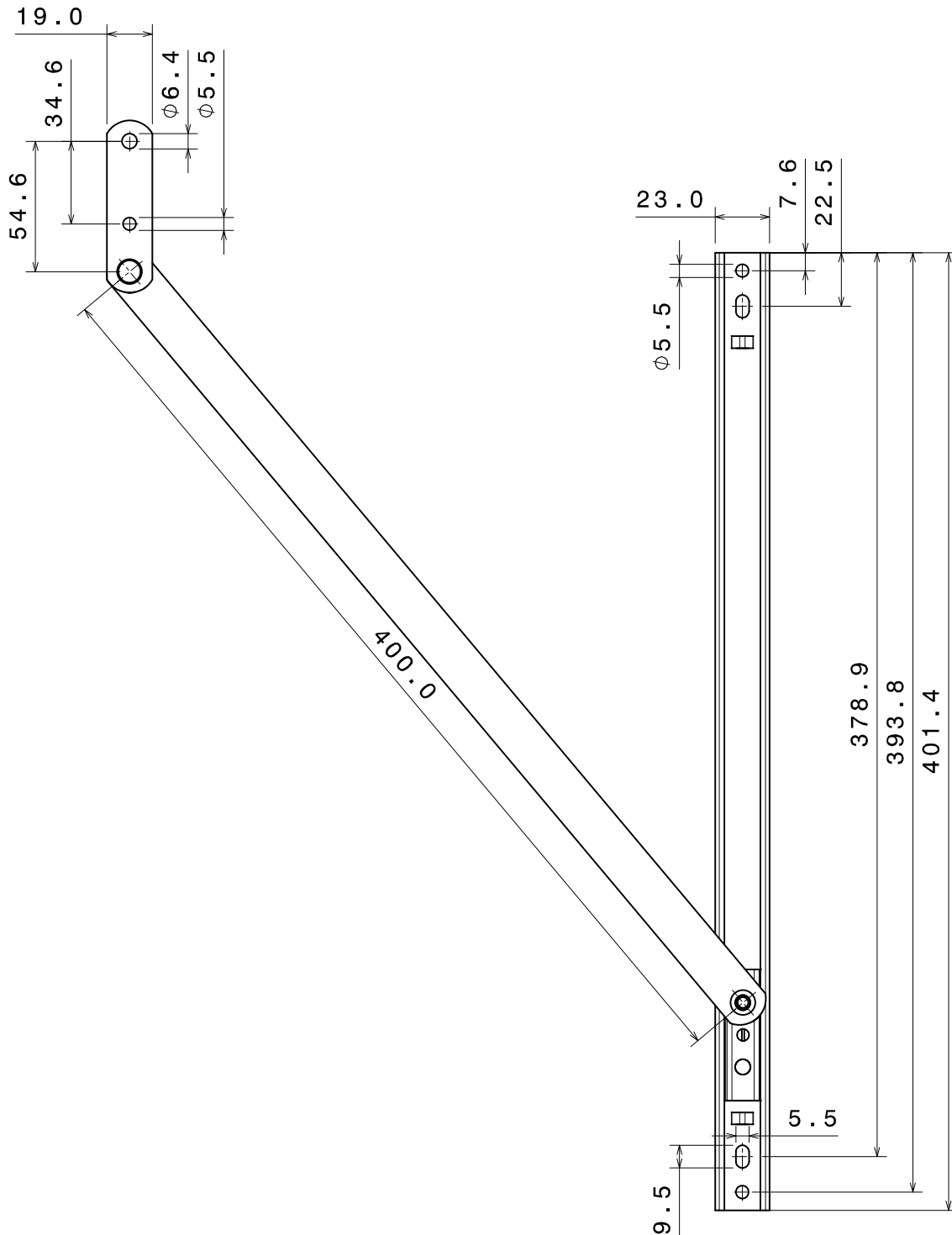

**Not to Scale, All dimensions in inches & mm**

It is the responsibility of the user to ensure that this document is at the latest issue.

Due to our policy of continual product improvement we reserve the right to alter specifications without notice.

It is the responsibility of the window manufacturer to ensure that the finished window meets the required performance and safety specification.



Securistyle Ltd.  
Kingsmead Industrial Estate  
Princess Elizabeth Way, Cheltenham,  
Gloucestershire, GL51 7RE  
Tel: +44 (0) 1242 221200  
Fax: +44 (0) 1242 520828  
Web: www.securistyle.co.uk

# ANCILLARY DEVICES

## ASSEMBLY SHEET - SR16BAC

### Restrictor Stays

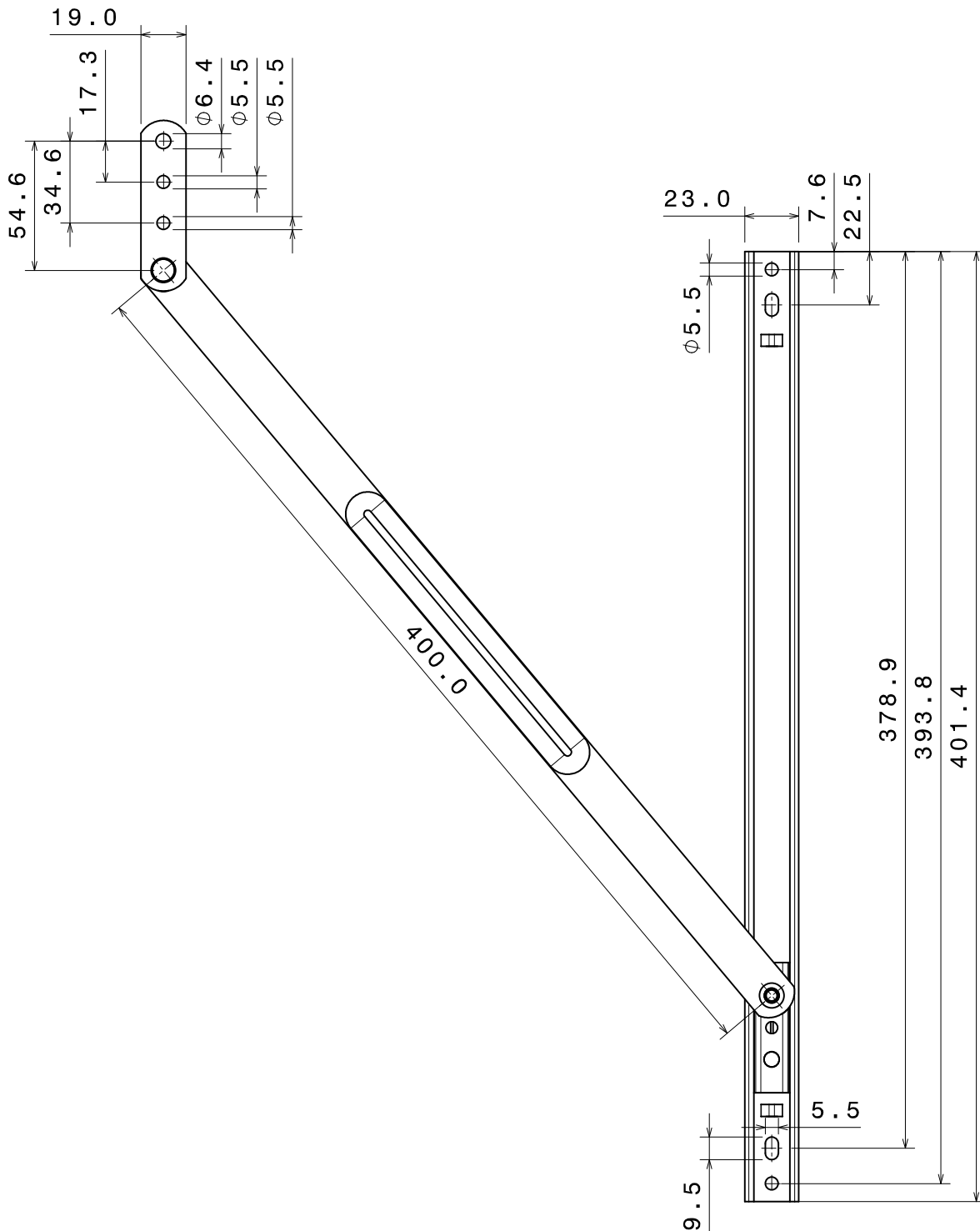

**Not to Scale, All dimensions in inches & mm**

It is the responsibility of the user to ensure that this document is at the latest issue.

Due to our policy of continual product improvement we reserve the right to alter specifications without notice.

It is the responsibility of the window manufacturer to ensure that the finished window meets the required performance and safety specification.



Securistyle Ltd.  
Kingsmead Industrial Estate  
Princess Elizabeth Way, Cheltenham,  
Gloucestershire, GL51 7RE  
Tel: +44 (0) 1242 221200  
Fax: +44 (0) 1242 520828  
Web: www.securistyle.co.uk

# ANCILLARY DEVICES

## ASSEMBLY SHEET - SDR4 Detachable Restrictor Stay

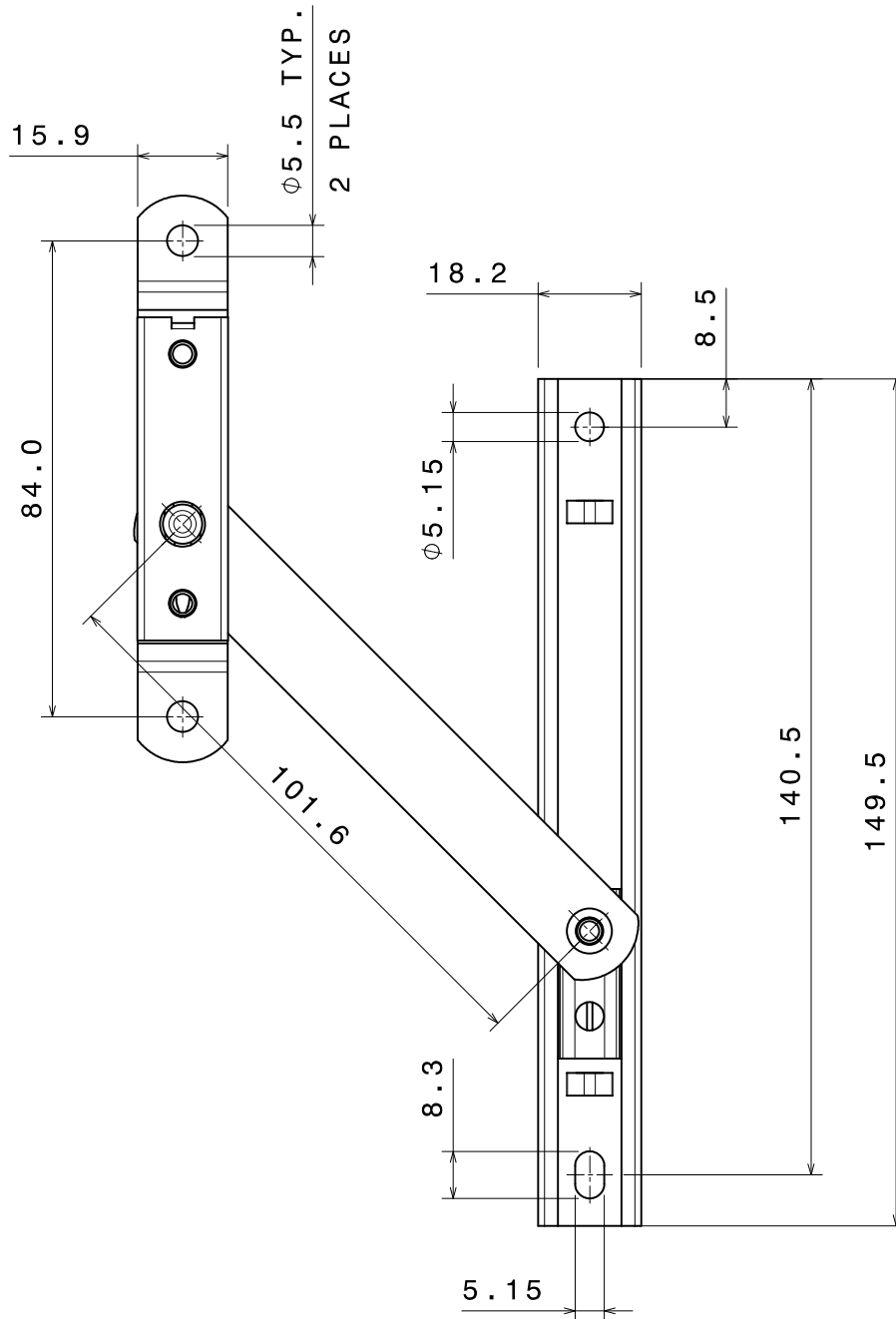

**Not to Scale, All dimensions in inches & mm**

It is the responsibility of the user to ensure that this document is at the latest issue.

Due to our policy of continual product improvement we reserve the right to alter specifications without notice.

It is the responsibility of the window manufacturer to ensure that the finished window meets the required performance and safety specification.



# ANCILLARY DEVICES

## ASSEMBLY SHEET - SDR6 Detachable Restrictor Stay

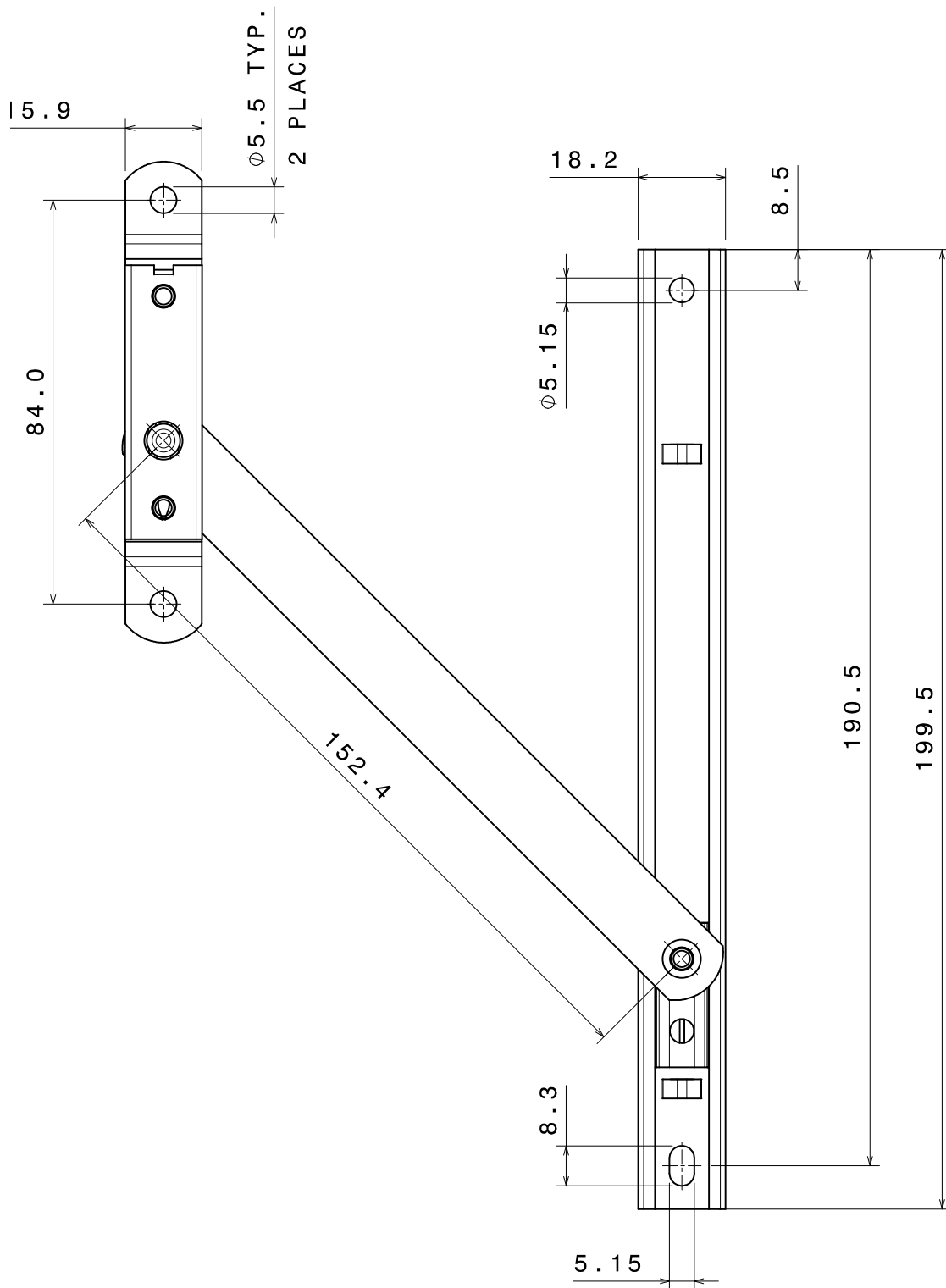

**Not to Scale, All dimensions in inches & mm**

It is the responsibility of the user to ensure that this document is at the latest issue.

Due to our policy of continual product improvement we reserve the right to alter specifications without notice.

It is the responsibility of the window manufacturer to ensure that the finished window meets the required performance and safety specification.



Securistyle Ltd.  
Kingsmead Industrial Estate  
Princess Elizabeth Way, Cheltenham,  
Gloucestershire, GL51 7RE  
Tel: +44 (0) 1242 221200  
Fax: +44 (0) 1242 520828  
Web: www.securistyle.co.uk

# ANCILLARY DEVICES

## ASSEMBLY SHEET - SDR8 Detachable Restrictor Stay

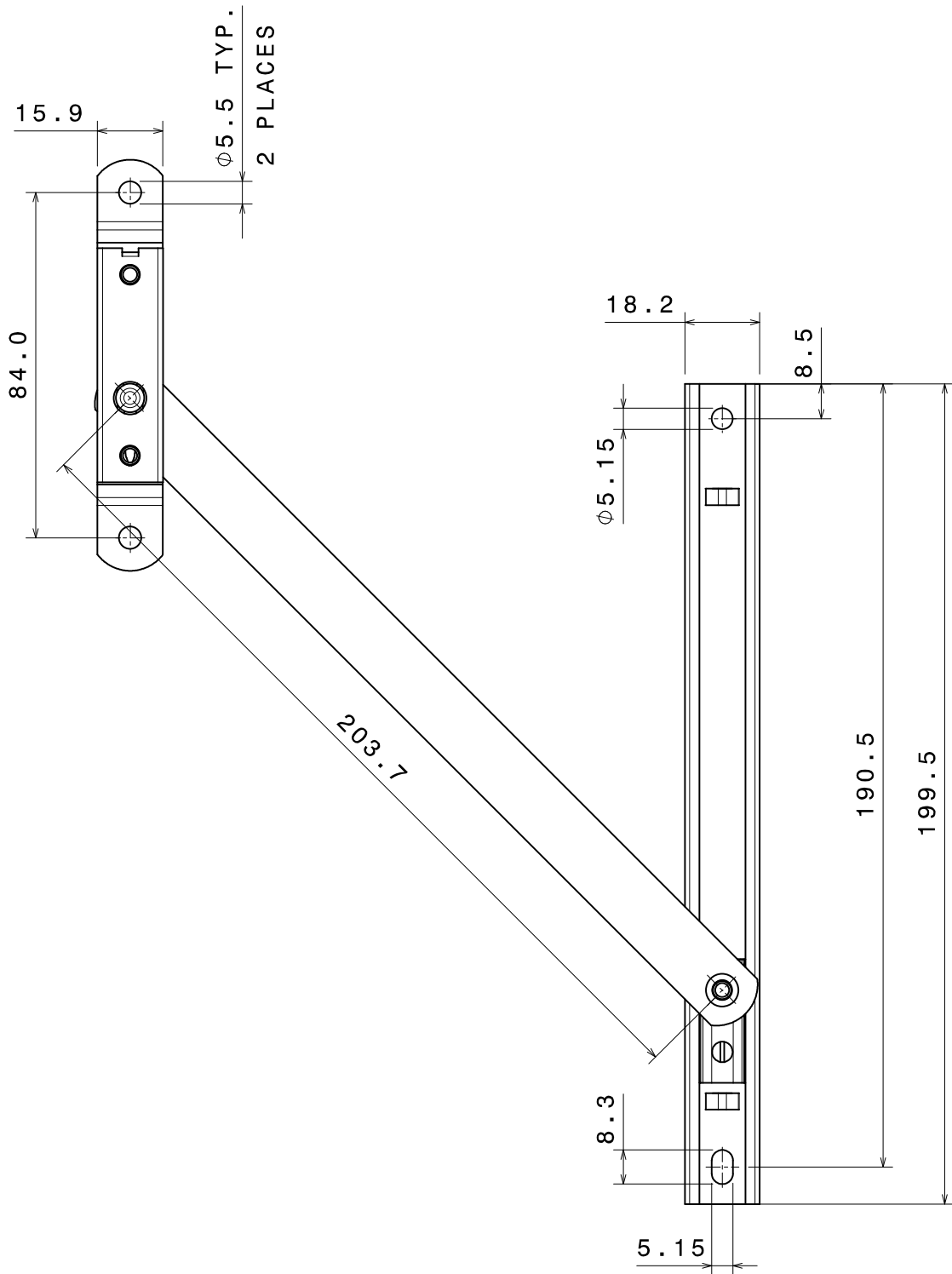

**Not to Scale, All dimensions in inches & mm**

It is the responsibility of the user to ensure that this document is at the latest issue.

Due to our policy of continual product improvement we reserve the right to alter specifications without notice.

It is the responsibility of the window manufacturer to ensure that the finished window meets the required performance and safety specification.



# ANCILLARY DEVICES

## ASSEMBLY SHEET - SDR10

### Detachable Restrictor Stay

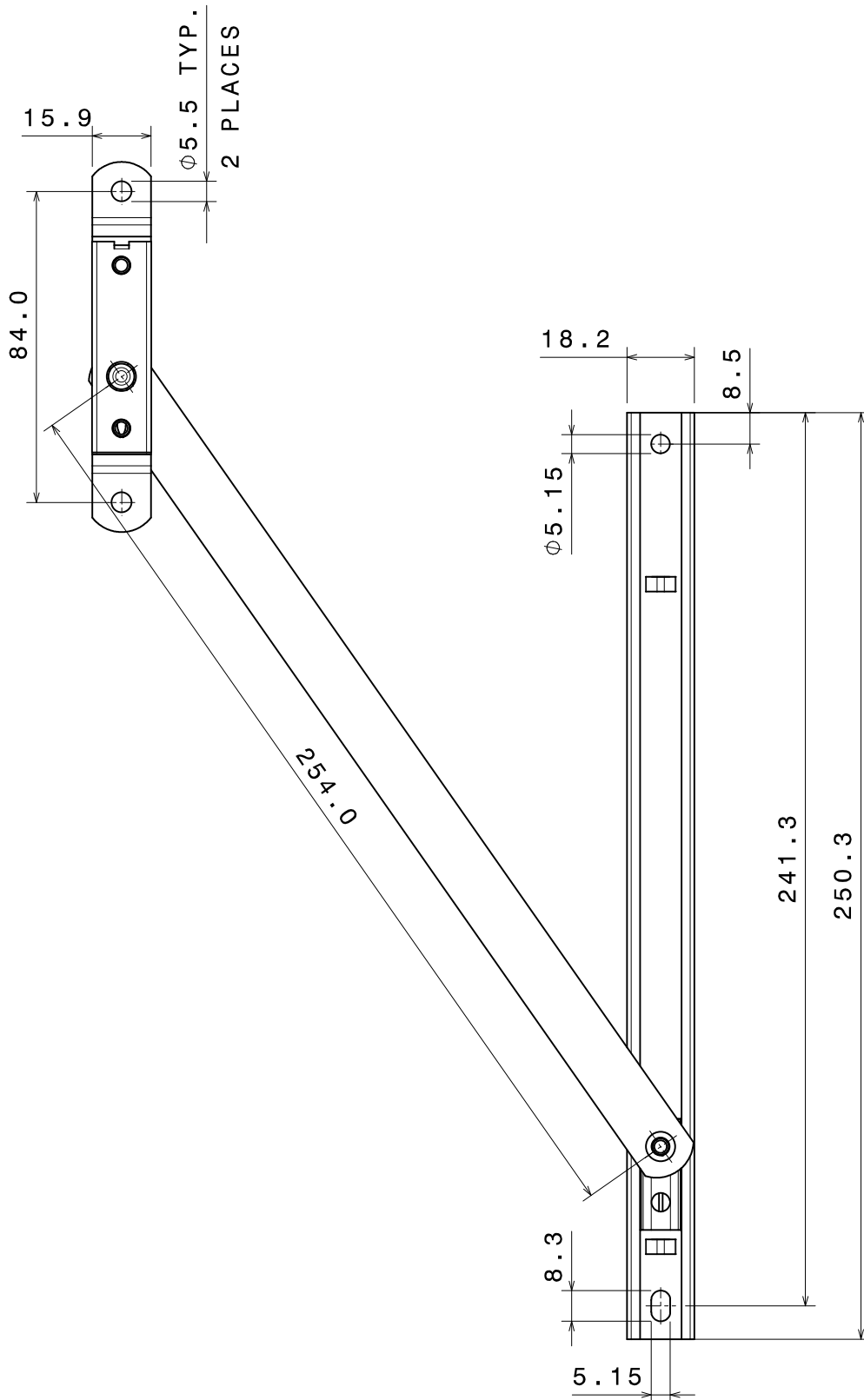

**Not to Scale, All dimensions in inches & mm**

It is the responsibility of the user to ensure that this document is at the latest issue.

Due to our policy of continual product improvement we reserve the right to alter specifications without notice.

It is the responsibility of the window manufacturer to ensure that the finished window meets the required performance and safety specification.

