

Product Catalogue
03/2019

PVC-U window

activPilot Concept

The turn-tilt fitting system for PVC-U windows.



1

The components specially developed for threshold solutions (sash and frame side) can be gathered from the catalogue "Complementary range activPilot threshold components...".

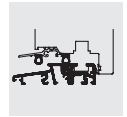

The processing details regarding burglary-resistant window units can be gathered from the DIN EN 1627 - 1630 system documentation. The lists of fittings in this catalogue are merely intended to give application examples. Please get in touch with your Winkhaus contact partner.











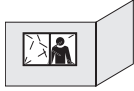

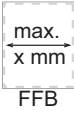

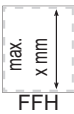



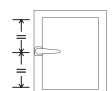





The following information and illustrations reflect the current state of our development and manufacturing of these products. In order to achieve customer satisfaction and reliability of the hardware components we reserve the right to change the product. Any information given in this document has been compiled and verified with the greatest care. Some of the indicated dimensions are rounded measures! Due to the constant technical progress, changes in legislation and other inevitable changes, we cannot accept any responsibility for the accuracy and completeness of the contents. We are always thankful for suggestions and comments. Taking into account the information and facts given here with regard to windows (and doors), the fitting system can easily be installed.

Copyright:

© Aug. Winkhaus GmbH & Co. KG, all rights and modifications are reserved.

Declaration of symbols

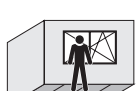
	Sash weight max. x kg		Exterior view
	Max. sash size: x m ²		Basic set of fittings
	Max. sash rebate width (FFB): x mm		Optional fittings
	Max. sash rebate height (FFH): x mm		Size-dependent fittings depending on sash rebate width (FFB)
	Constant handle height		Size-dependent fittings depending on sash rebate height (FFH)
	Central handle height		"TOP" marks the upper edge of the window.
	Turn sash (D)		Pot hinge version
	Turn-tilt sash (DK)		Rebate hinge version
	Turn/Turn-tilt double sash (D/DK-Stulp)		Item for use on PVC-U windows
	Turn or turn-tilt sash with parallel opening		Item for use on wooden windows with 12 mm airgap
	Parallel action		Item for use on aluminium windows
	Slide-tilt window		Component for use in threshold solutions
	Interior view		

		Page	
1	General product information	2 - 23	1
2	Lists of Fittings	24 - 50	2
3	Drive rods	51 - 77	3
4	Corner drives	78 - 86	4
5	Top rods	87 - 89	5
6	Sash hinges / Corner hinges	90 - 98	6
7	Shears / Shear hinges	99 - 117	7
8	Turn hinges / Tilt hinges	118 - 123	8
9	Extension rods	124 - 131	9
10	Accessories	132 - 154	10
11	Frame parts	155 - 162	11
12	Mounting accessories	163 - 168	12
13	Mounting Instructions	169 - 212	13
14	Adjustment / maintenance	213 - 216	14
15	Installation drawings	217 - 223	15

Many windows, many formats, one single fitting system.

activPilot: The approved standard of turn-tilt fittings

Developing a new system of fittings from the initial drafts to market maturity is a time-consuming process. It is not just a question of creative ideas, precise calculations and countless series of tests, but also of intensive monitoring of people and markets, evaluating current trends and ongoing analysis of general technical developments. We even question tried and trusted approaches to be able to leverage all this information, and apply our years of experience to create targeted, premium solutions that offer fitters and users a whole new range of opportunities. Both from an economical and functional point of view. It is this constant drive towards precision that has made Winkhaus one of the leading enterprises in the field of window and door technology. This is evident by the large number of industry standards that Winkhaus has established in over 160 years.

The standard of activPilot

In designing activPilot we created all the solutions needed for the next-generation window fitting standard within a single system. An intelligent, clearly-structured modular system with far less components than was previously typical, activPilot meets all your requirements from a modern range of fittings. activPilot is suitable for any shape of window, any window material and any level of automation, from manual mounting to fully automated serial production. The high level of flexibility, the attractive auxiliary functions, the new locking system and the functional design all ensure that your business is perfectly geared today to meet your customers' needs and future requirements.

Modular design

activPilot optimises window construction. For the window builder, less components and multifunctionality mean uncomplicated and fast processing and rational mounting. Pre-mounted components and the unique design furthermore ensure that additional functions and safety classes can be achieved easily by retrofitting. activPilot thus sets the scene for sustainably cutting your production, warehousing, logistics and administration costs.

The locking system with octagonal locking bolts

activPilot enhances comfort. The functionally perfect locking mechanism not only guarantees precise entry of the locking bolt into the frame keep, but also a perfect seal. This is ensured by the excellent air gap tolerance and the octagonal locking bolt which allows easy adjustment of the contact pressure. Even adjusting forces and the non-positive and positive system fit of the components give this fitting the required stability and long-term functionality.

Add-on functions

activPilot gives you the ability to react flexibly to customer requests. Innovative multi-purpose components make it easy to retrofit features at any time. The use of a duo and/or tri functional element makes it simple to add a fail safe device with integrated limiter support and balcony door catch. The variable tilt device supports different sash tilt angles and thus fast, easily adjustable ventilation settings.

Design

activPilot offers you and your customers real added value. Surprising details, discreet accents, ergonomic design and comprehensive functions characterise the overall concept of the fitting system. In short, its attractive design will be a crucial factor when it comes to your customers making a purchase decision. activPilot also offers other convincing arguments such as outstanding durability, easy-to-clean surfaces, intuitive operation and, last but not least, aesthetically pleasing windows.

Surface

activPilot fittings feature a surface refinement finish based on nanotechnology, which is applied in our in-house electroplating facility. This surface stands out due to its very high resistance to all environmental influences. This is verified by quality controls consisting of alternate climate and salt spray testing according to DIN EN ISO 9227 and is certified on a regular basis by tests. Winkhaus also carries out tests in outside areas, thus testing component behaviour under realistic conditions. This enables Winkhaus to offer a ten-year warranty for functions and surfaces.

Effective security

Thanks to the unique modular system, any window can be modified to achieve the required security standard – easily, quickly and cost-efficiently. There is no need for custom parts. Depending on the number and type of keeps, various security levels are achievable using the same platform. At our works, comprehensive and strict tests – along with ongoing functional monitoring – ensure maximum security for customers. Approval marks and certificates by independent test authorities confirm our results. You can therefore be sure that activPilot meets the requirements customers place on a secure fitting system. Locking bolts are made of high-strength steel; even standard types guarantee effective basic security. Depending on the number and type of keeps, the fitting system can be enhanced for compliance with stricter security classes – including burglar protection to DIN EN 1627-1630, resistance class 2 (RC2).

Quality standard

The Winkhaus group successfully passed a group certification of production sites according to DIN EN ISO 9001:2015 / DIN EN ISO 50001:2011. The group certification ensures that we use the same criteria and procedures in all Winkhaus subsidiaries and thus we can always offer consistent quality for our customers.



Winkhaus has successfully passed the demanding QM 328 certification.

Winkhaus' activPilot fittings are certified in accordance with QM 328. The turn-only and turn-tilt fittings for windows and French doors undergo a large number of tests in the stringent certification programme, which verifies aspects such as durability and quality control mechanisms. The certificate stands as a testament to Winkhaus' long tradition in high quality products.

Endurance test

Winkhaus activPilot is certified in accordance with EN 13126-8 (endurance test for turn-only and turn-tilt fittings) and EN 1191 (endurance test for windows and doors). The fitting system thus complies with the latest EN standards. Winkhaus' own permanent control in accordance with established production control guidelines as well as regular external monitoring by ift Rosenheim ensure outstanding product quality guaranteed on a long-term basis. The activPilot Concept fitting series was tested for sash weights of up to 130kg, for activPilot Select up to 150 kg and for activPilot Comfort up to 100 kg. As a result they clearly exceeded the required load values. The fittings may now bear the ift quality certification mark.

Your partner for service

Our services are solution-oriented, reliable and precisely geared to match your requirements – just as you would expect from your partner. We are always at your service. With application engineers on site, professional help from our product data service, and innovative software solutions to help optimise your workflow we safeguard and extend your capacity to act. On top of this, our comprehensive product information system and sophisticated logistics service guarantee fast delivery at all times.

Proper screw fixing in terms of load of security-relevant fitting components

In order to ensure the endurance and operating safety of windows and balcony doors over their expected service life, major importance must be attached to the installation of security-relevant fitting components! Manufacturers of windows and balcony doors are responsible for fixing the fitting elements on the sash and the frame in a professional way and they must make sure that the specifications are adhered to. Important: Please observe these guidelines! Use only screws that are long enough to bear the loads. We recommend you to fix the corner and shear hinge screws in the steel reinforcement of the PVC-U window.

Basic technical features of the activPilot fitting system

In the following section you will find the general features that apply to all activPilot fitting components in the sash area, unless otherwise described on the corresponding product pages.

- Face plate width of sash fitting parts: 16 mm
- Overlapping system linkage without connecting plates
- Delivery state of sash fitting parts: centre fixed in turn position
- Safety locking pin as an adjustable octagonal bolt
- Sash fitting parts can be used right/left, unless otherwise stated.

Zertifikat / Certificate



Zertifikatsnr. / Certificate No.: 228-7019950-1-16

Dreh- und Drehkippsbeschläge für Fenster und Fenstertüren Turn and tilt-turn hardware for windows and casement doors

Produkt
product **activPilot, proPilot**

max. Flügelgewicht
max. casement weight **max 200 kg**

Einsatzbereich
field of application **Systeme mit entsprechender Beschlagaufnahme**
Systems with suitable hardware groove

Hersteller
manufacturer **Aug. Winkhaus GmbH & Co. KG**
August-Winkhaus-Str. 31, D 48291 Telgte

Produktionsstandort
production site **Aug. Winkhaus GmbH & Co. KG**
August-Winkhaus-Str. 31, D 48291 Telgte



Mit diesem Zertifikat wird bescheinigt, dass das benannte Bauprodukt den Anforderungen des zugrundeliegenden ift-Zertifizierungsprogramms in der aktuellen Fassung entspricht.

- Erstellung von Produktfamilien des aufgeführten Bauproduktes und Erstprüfung durch eine akkreditierte Prüfstelle nach EN 13126-8:2017 unter Berücksichtigung der Anwendungsdiagramme
- Einführung und Aufrechterhaltung einer werkseigenen Produktionskontrolle durch den Hersteller
- Erstinspektion des Werkes und der werkseigenen Produktionskontrolle durch ift-Q-Zert
- kontinuierliche Fremdüberwachung des Werkes und der werkseigenen Produktionskontrolle durch ift-Q-Zert

Dieses Zertifikat wurde erstmals am 18. November 2008 ausgestellt und gilt 5 Jahre, wenn sich zwischenzeitlich die Festlegungen in der oben angeführten technischen Spezifikation oder die Herstellbedingungen im Werk oder in der werkseigenen Produktionskontrolle selbst nicht wesentlich verändert haben.

Das Zertifikat darf nur unverändert vervielfältigt werden. Alle Änderungen der Voraussetzungen für die Zertifizierung sind dem ift-Q-Zert mit den erforderlichen Nachweisen unverzüglich schriftlich anzuzeigen.

Das Unternehmen ist berechtigt, das benannte Bauprodukt gemäß der ift-Zeichensatzung mit dem „ift-zertifiziert“-Zeichen zu kennzeichnen.

Dieses Zertifikat enthält 2 Anlage/n.

This certificate attests that the building product mentioned fulfills the requirements of the underlying ift-certification scheme in its current version.

- compilation of product families of the building product listed and initial type-testing by an accredited testing body as per EN 13126:8:2017 based on the application diagrams
- implementation and maintenance of a factory production control by the manufacturer
- initial inspection of the production site and the factory production control by ift-Q-Zert
- continuous third-party control of the production site and the factory production control by ift-Q-Zert

This certificate was first issued on 18. November 2008 and will remain valid for 5 years, as long as neither the conditions laid down in the technical specification listed above nor the manufacturing conditions in the production site nor the factory production control itself are modified significantly.

The reproduction of the certificate without any change from the original is permitted. Any changes to the prerequisites applicable to certification shall be immediately communicated in writing to ift-Q-Zert accompanied by the necessary evidence.

The company is authorized to affix the "ift-certified"-mark to the building product mentioned according to the ift-rules for use of the "ift-certified"-mark.

This certificate contains 2 annexes.

Grundlage(n) / Basis:

ift-Zertifizierungsprogramm für Beschläge
ift-certification scheme for hardware (QM 328)
Ausgabe/issue 2018

EN 1191
EN 12400
bis Klasse 3
up to class 3



Dauerfunktion
resistance to repeated opening and closing

EN ISO 9227

EN 1670
bis Klasse 5
up to class 5



Korrosionsschutz
corrosion protection

ift Rosenheim
11. Oktober 2018

Christian Kehrer
Leiter der ift-Zertifizierungs- und Überwachungsstelle
Head of ift Certification and Surveillance



Prof. Ulrich Sieberath
Institutsleiter
Director of Institute

228 7019950

Gültig bis / Valid until:

10. Oktober 2023

2018-01 / 797



www.ift-rosenheim.de

ift Rosenheim GmbH
Theodor-Gietl-Str. 7-9
D-83026 Rosenheim

Kontakt
Tel.: +49 8031 261-0
Fax: +49 8031 261-290
www.ift-rosenheim.de

Prüfung und Kalibrierung – EN ISO/IEC 17025
Inspektion – EN ISO/IEC 17020
Zertifizierung Produkte – EN ISO/IEC 17085
Zertifizierung Managementsysteme – EN ISO/IEC 17021

Notified Body 0757
PUZ-Stelle: BAY 18



You will find further certificates and updates at www.winkhaus.de.

Anlage / annex 1
 Hersteller / manufacturer:
 Aug. Winkhaus GmbH & Co. KG
 Ausgabedatum / date of issue: 11. Oktober 2018

Seite / page 1 von / of 3
 Aug. Winkhaus GmbH & Co. KG
 11. Oktober 2018



Zertifikatsnr. / Certificate No.: 228-7019950-1-16

In der Zertifizierung enthaltene Produktfamilien für Fenster- und Fenstertürsysteme mit geeigneter Beschlagsaufnahme.

Product families for window and casement door systems with groove designed for accommodation of hardware, covered by certification.

lfd. Nr./ no.	Ausführung Bandscheitel/ type hinge side	Ausführung Flügelbeschlag/ type casement hardware	Beschreibung der Ausführung der blendrahmenseitigen Beschlagsaufnahme <i>detail description of frame member hardware type</i>				Klassifizierung nach EN 13126-8:2017 <i>classification as per EN 13126-8:2017</i>			
			Winkelband/ top stay connecting part	Scherenlager/ stay arm support	Eckband/ corner hinge	Ecklager/ corner pivot	1 Dauerfunktionsfähigkeit/ durability	2 Masse (in kg)/ mass	3 Korrosionsbeständigkeit/ corrosion resistance	4 Prüfgrößen (in mm)/ test sizes
1	activPilot K 100	activPilot K 100	SK2.20-13	SL.KS.3-6	FL.K. 20-6-20	EL.K. 6-3-16	H2	100	5	1300 mm x 1200 mm
2	activPilot K 100	activPilot K 100	SK2.20-13	SL.KS.3-6	FL.K. 20-6-20	EL.K. 6-3-16	H2	100	5	900 mm x 2300 mm
3	activPilot K 130 S	activPilot K 130 S	SK2.20-13	SL.K.3-6.130	FL.K. 20-6-28.130	ESV 6-3-16	H3	100	5	1300 mm x 1200 mm
4	activPilot Comfort PADK 100	activPilot Comfort PADK 100	SK2.PA.20-13	SL.KS.3-6	FL.E.FWPA 20-13	ESV 6-3-16	H2	100	5	1300 mm x 1200 mm
5	activPilot Comfort PADK 100	activPilot Comfort PADK 100	SK2.PA.20-13	SL.KS.3-6	FL.E.FWPA 20-13	ESV 6-3-16	H2	100	5	900 mm x 2300 mm
6	activPilot Comfort PADM 100	activPilot Comfort PADM 100	SK2.PAD. 20-13	SL.KS.3-6	FL.E.FPAD 20-13	ESV 6-3-16	H2	100	5	1300 mm x 1200 mm
7	activPilot Comfort PADM 100	activPilot Comfort PADM 100	SK2.PAD. 20-13	SL.KS.3-6	FL.E.FPAD 20-13	ESV 6-3-16	H2	100	5	900 mm x 2300 mm
8	activPilot C 130	activPilot C 130	SK2.20-13.P	SL.C.3-6	FL.C-W. 20-13	EL.CS. 6-3-22	H3	130	5	1400 mm x 1550 mm
9	activPilot K 130	activPilot K 130	SK2.20-13	SL.KB.3-6	FWV 20-13	ESVW 6-3-16	H2	130	5	1300 mm x 1200 mm

Anlage / annex 1
 Hersteller / manufacturer:
 Aug. Winkhaus GmbH & Co. KG
 Ausgabedatum / date of issue: 11. Oktober 2018

Seite / page 2 von / of 3
 Aug. Winkhaus GmbH & Co. KG
 11. Oktober 2018



Zertifikatsnr. / Certificate No.: 228-7019950-1-16

10	activPilot K 130	activPilot K 130	SK2.20-13	SL.KB.3-6	FWV 20-13	ESVW 6-3-16	H2	130	5	900 mm x 2300 mm
11	activPilot ALU 130	activPilot ALU 130	SK2.20-13	SL.KB.3-6	FWV 20-13	ESVW 6-3-16	H2	130	5	1300 mm x 1200 mm
12	activPilot ALU 130	activPilot ALU 130	SK2.20-13	SL.KB.3-6	FWV 20-13	ESVW 6-3-16	H2	130	5	900 mm x 2300 mm
13	activPilot K 130 S	activPilot K 130 S	SK2.20-13	SL.K.3-6.130	FL.K. 20-6-28.130	ESV 6-3-16	H2	130	5	1300 mm x 1200 mm
14	activPilot K 130 S	activPilot K 130 S	SK2.20-13	SL.K.3-6.130	FL.K. 20-6-28.130	ESV 6-3-16	H2	130	5	900 mm x 2300 mm
15	activPilot H 130	activPilot H 130	SH2.T. 18-13-12	SL.HT.18-12	FL.HT. 18-13-12	EL.HT.Z. 18-12	H3	130	5	1300 mm x 1200 mm
16	activPilot H 150	activPilot H 150	SH2.T. 18-13-12	SL.HT.18-12	FL.HT. 18-13-12	EL.HT.Z. 18-12	H3	150	5	900 mm x 2300 mm
17	activPilot Giant	activPilot Giant	SXL.20-13	SL.XL	FL.XL	EL.XL	H3	200	5	1550 mm x 1400 mm
18	activPilot Giant	activPilot Giant	SXL.20-13	SL.XL	FL.XL	EL.XL	H2	200	5	900 mm x 2300 mm
19	activPilot Select K 100	activPilot Select K 100	SK.SE	ohne without	FL.SE	EL.K.SE	H2	100	5	1300 mm x 1200 mm
20	activPilot Select H 130	activPilot Select H 130	SH.SE. 20-9.Z.	ohne without	FL.SE	EL.H.SE. 20-9.Z. mit/with FLS.SE	H2	130	5	1300 mm x 1200 mm

Anlage / annex 1
 Hersteller / manufacturer:
 Ausgabedatum / date of issue:

Seite / page 3 von / of 3
 Aug. Winkhaus GmbH & Co. KG
 11. Oktober 2018



Zertifikatsnr. / Certificate No.: 228-7019950-1-16

21	activPilot Topstar	activPilot Topstar	SH.IF.24-13	ohne without	FL.IF	EL.H.IF.24-13	H2	130	5	1300 mm x 1200 mm
22	activPilot Topstar	activPilot Topstar	SH.IF.24-13	ohne without	FL.IF	EL.H.IF.24-13	H2	130	5	900 mm x 2300 mm
23	activPilot Select K 150	activPilot Select K 150	SK.SE	ohne without	FL.SE	EL.K.SE mit/with FLS.SE	H2	150	5	1550 mm x 1400 mm
24	activPilot Select K 150	activPilot Select K 150	SK.SE	ohne without	FL.SE	EL.K.SE mit/with FLS.SE	H2	150	5	900 mm x 2300 mm
25	activPilot Select ALU 150	activPilot Select ALU 150	SK.SE	ohne without	FL.SE	EL.K.SE mit/with FLS.SE	H2	150	5	1550 mm x 1400 mm
26	activPilot Select H 150	activPilot Select H 150	SH.SE.29-13	ohne without	FL.SE	EL.H.SE.29-13 mit/with FLS.SE	H2	150	5	1550 mm x 1400 mm
27	proPilot	proPilot	SK.U.2.20-13	SL.K.U.3-3	FL.K.U.6	EL.K.U.3-3	H2	70	4	1300 mm x 1200 mm
28	proPilot	proPilot	SK.U.2.20-13	SL.K.U.3-3	FL.K.U.6.100	EL.K.U.3-3	H2	100	4	1300 mm x 1200 mm

Die Ergebnisse sind auf folgende Ausführungsvarianten übertragbar: Beschlagsausführung links/rechts, alle zulässigen Größen gemäß Anwendungsdiagramm sowie andere Falz- und Profillegeometrien. Die technische Dokumentation des Beschlagherstellers, insbesondere die entsprechenden Anwendungsdiagramme, ist zu beachten.

The results can be applied to the following design variants: hardware type left/right, all permissible sizes in accordance with the application diagram as well as other rebate and profile geometries. Observe technical documents of hardware manufacturer, in particular the relevant diagrams.

Obligations regarding information and instructions

This document comprises important information and details regarding different fittings and their further processing. The information in this document is particularly intended for window and patio door manufacturers and fitting and structural component retailers. Accidents and physical damage can be avoided if you observe the information given here. For this reason, you must always make sure to pass on the relevant documents when submitting fittings over to somebody else. Information and documents should be handed over in printed form, on a CD ROM or online, for example.

Guidelines for the use of locking systems and fittings

Gütegemeinschaft Schlösser und Beschläge e.V., Velbert issues guidelines offering assistance for the use of locking systems and fittings for windows, doors and patio doors. These guidelines are established in cooperation with the trade association of the locks and fittings industry in Velbert as well as the testing institute PIV which is also based in Velbert. If required, they are agreed with the VFF technical committee and ift Rosenheim. As a result the experience and test findings of several decades are considered. The guidelines provide information about the intended use and maintenance of fittings for windows and patio doors. It is mandatory to observe these guidelines. The current guidelines can be accessed in different languages at the following Internet address: <http://www.beschlagindustrie.de/ggsb/richtlinien.asp>



As an alternative to using the www address, you can also scan the QR Code with your smartphone!

Follow this link to find the applicable and binding guidelines on the following topics:

- VHBH - Fittings for windows and patio doors [with guidelines / instructions on the product and liability]
- VHBE - Fittings for windows and patio doors [with guidelines / instructions for end users]
- TBDK - Attachment of supporting fitting components of turn and turn-tilt fittings [with definitions of turn and turn-tilt fittings as well as their possible mounting positions]
- FPKF - Safety and cleaning shears for tilt sashes and tilting fanlights [use of safety and cleaning shears]
- FPDF - Sash limiters for variable turn position of sashes [sash limiters controlled by central locking system - definitions and tests]



The VHBH guideline among others contains the chapter "Obligation to give instructions". A schematic illustration shows the documents and information to be submitted to the different target groups. The builder is obliged to pass the documents listed in this chapter on to the end user.



Gütegemeinschaft Schlösser und Beschläge e.V.

Richtlinie: TBDK

ORIGINALFASSUNG Ausgabe: 2014-05-05

Richtlinie

Befestigung tragender Beschlagteile von Dreh- und Drehkipps-Beschlägen
 m: Definitionen zu Dreh- und Drehkipps-Beschlägen sowie deren möglichen Einbaulagen

Inhalt

1	Vorwort	3
2	Anwendungsbereich	3
3	Begriffe	4
4	Dauerfunktionsfähigkeit – Grenzen der Richtlinie	7
5	Empfehlungen für die Befestigung	9
6	Durchführung der Prüfungen	9
7	Vorgaben zu den Kräften	15
8	Literaturhinweise	22

Herausgeber:

Gütegemeinschaft Schlösser und Beschläge e.V.
 Offerstraße 12
 42551 Velbert

Phone: +49 (0)2051 / 95 06 - 0
 Fax: +49 (0)2051 / 95 06 - 20
 www: www.beschlagindustrie.de
www.beschlagindustrie.de/ggsb/richtlinien.asp

Hinweis

Technische Angaben und Empfehlungen dieser Richtlinie beruhen auf dem Kenntnisstand bei Drucklegung. Es gilt der Inhalt des „Disclaimer“ auf der o.g. Internet-Seite.

Richtlinie TBDK
1 / 23

Product liability guidelines

Turn and turn-tilt fittings for windows and patio doors

According to the current product liability legislation dealing with a manufacturer's liability for his products please observe the following information on turn and turn-tilt fittings for window and patio door sashes. The manufacturer will not accept any liability for noncompliance with these specifications.

1. Product Information and intended use

Turn and turn-tilt fittings within the meaning of this definition are single handle turn-tilt fittings for windows and patio doors as used in building applications. These interact with a manually operated handle to bring windows and window sashes into a turn or a tilt position as defined by the design of the shears. Turn and turn-tilt fittings are used on vertical installation windows and patio doors made of wood, PVC-U, aluminium or steel and corresponding combinations of materials. Standard turn-tilt fittings within the meaning of this definition are used for securing window and patio door sashes and to position them in different ventilation positions. Normally it is necessary to overcome the counter force of a seal when closing. Any other type of usage is not in accordance with the intended application. Windows and patio doors for special applications (i.e. burglar-resistance or for installation in humid conditions / in environments with corrosive atmospheric substances) require special fittings with separately agreed performance criteria, designed for the particular application. Open window and patio door sashes only have a protective function and do not meet requirements in terms of joint sealing, watertightness under heavy rain, sound proofing, heat insulation or burglar resistance. When it is windy or draughty, windows and window sashes need to be closed and locked. Windy or draughty as used in this definition means conditions when window or patio door sashes open or close unexpectedly by themselves as a result of air pressure or suction. A fixed open position of the window or patio door sashes can only be achieved by means of supplementary locking fittings. Resistance to loads imposed by wind on closed and locked windows depends on the design and construction of the individual windows / patio doors concerned. If wind stresses to DIN EN 12210 (pressure level p3 in particular) have to be withstood, suitable combinations of fittings must be designed and agreed separately for the design of window and frame material concerned. In general, the turn and turn-tilt fittings are able to meet the requirements to DIN 18025 relating to low-threshold design of flats. However, in this case special combinations and assembly of fittings are needed which must be adjusted and approved separately.

2. Misuse

Misuse – i.e. the use of a product in a manner contrary to the manufacturer's instructions – of turn-tilt fittings for windows and patio doors occurs

- if obstacles are placed in the opening area preventing the intended use.
- if sashes of window / patio doors are pushed or hit against the window reveal, either contrary to the manufacturer's instructions or in an uncontrolled way (e.g. by wind), that the fittings, the frame materials or other individual parts of the window sash or the patio door sash are damaged or destructed or subsequent damage occurs.
- if additional loads act on the sashes of windows or patio doors (e. g. children swinging on them).
- if someone grasps in the gap between the frame and sash when closing the window (risk of injury).

3. Liability

All fittings must be selected from the original Winkhaus activPilot fitting component range. We accept no liability in case of use of third party or non-approved system components.

Attention: The screw / clamping connection of fitting components, such as corner, shear and sash hinges, must be designed according to the TBDK guidelines. Please adapt the fixing procedure to the load situation.

4. Product Capabilities - Application instructions of the manufacturer

The maximum sash weights for the individual types of fitting must not be exceeded. The component with the lowest permissible loading capacity determines the maximum weight of the sash. Please observe the diagrams and component installation instructions.

4.1 Sash sizes and areas of application

The graphs in the application diagram show the permitted sash rebate height to width ratios, as determined by different weights of glass and/or overall glass thicknesses. The resulting sash rebate dimensions or sash formats (portrait / landscape) and the maximum sash weight must under no circumstances be exceeded.

4.2 Application diagram for determination of the permissible sash sizes

The application diagrams for this fitting series for the determination of permissible sash sizes are described and explained separately on the following pages.

4.3 Composition of fittings

You must comply with the manufacturer's specifications regarding the configuration of fittings (e.g. the use of additional shears, the layout of fittings for burglary-resistant windows and patio door sashes, etc.).

5. Product maintenance

Security-relevant fitting parts are to be inspected at least once a year to check for wear and to ensure they are firmly secured in position. Fastening screws must be tightened and faulty components must be replaced as required. Maintenance work and cleaning must also be carried out at least once a year. All mobile parts and locking points for fittings should be greased and tested for function. Only oils and greases not affecting the materials of the fitting may be used. The only cleaning and maintenance materials to be used are those which will not adversely affect the corrosion-resistant properties of the fittings components.



Adjustment work to the fittings – particularly in the area of the corner drive and the shears – as well as the replacement of parts and mounting and removal of opening sashes must be carried out by a trained specialist.

5.1 Maintaining surface quality

- The fittings and rebate spaces must be adequately ventilated, particularly during the construction stage, so that they are not exposed to the direct effects of moisture or condensation. It must be ensured in any case by appropriate measures that there is no possibility for (permanently) humid room air to condense in the rebate area.
- The fittings must be kept free from deposits and soiling due to building materials (building dust, gypsum plaster, cement etc). Possible soiling from plaster, mortar etc. must be removed prior to bonding with water.
- Corrosive vapours (e.g. formic acid, acetic acid, ammonia, amine and ammonia compounds, aldehydes, phenols, chlorine, tannic acid etc.) in the rebate space combined with even a small amount of condensation can cause rapid corrosion of the fittings. Therefore, such exhalations in the area of the windows must be avoided.
- Furthermore no sealants that cure with acetic or other acids, or sealants containing any of the above-mentioned substances, must be used. Both direct contact with the sealant and vapours released from it can damage the surface.
- Only use a mild and pH neutral detergent to clean the fittings. Under no circumstances use aggressive acidic cleaners or scouring agents containing the substances listed above.

6. Obligations to give information and instructions

For the implementation of information and instruction obligations as well as for the maintenance work the following documents are available. They must be submitted to (intermediate) dealers and manufacturers and to the end customer.

Planning documentation

Product catalogues

Mounting instructions

Maintenance and care instructions as well as operating instructions

7. Use of type-related fittings

The variants for the individual fitting systems (e.g. tilt and top-hung sash fittings or parallel action fittings providing an additional ventilation position by means of a circumferential gap all around the sash) must be used considering the product information, intended use, misuse, product capabilities, product maintenance and the obligations regarding the information and instruction.

8. Storage

Before the fitting components are assembled, they must be stored on a dry, protected and level surface.

activPilot Concept

Application diagram for ascertaining the admissible sash sizes

- Max. sash weight 100 kg

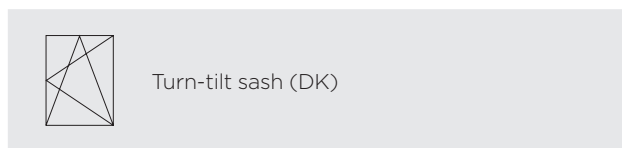
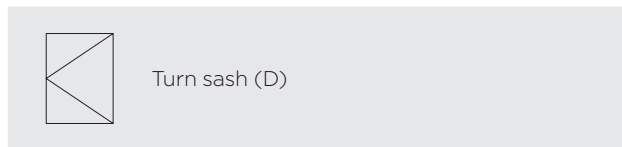
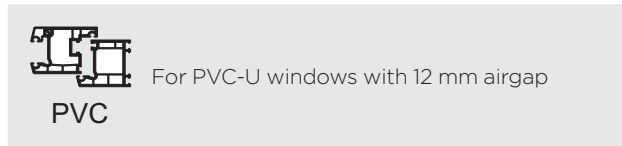

Width-to-height ratio and additional load

Value calculated without additional load for a width-to-height ratio of 2:1. The application diagrams have been established without considering additional loads. For ascertaining the max. sash sizes with additional loads, please ask your authorised contact partner for comprehensive advice!

Advice for use

The permissible application range for using Winkhaus fittings is marked grey in the application diagrams. However, please do not take into account the complete grey surface, but only the part which is on the left side of the "filling weight GG" curve.

Application range

All fittings must be selected from the original Winkhaus activPilot fitting component range. We accept no liability in case of use of third party or non-approved system components.

- Min. sash rebate width 270 mm
- Max. sash rebate width 1725 mm
- From 1475 mm sash rebate width with additional shear ZSR
- Min. sash rebate height 230 mm
- Max. sash rebate height 2,800 mm
- Max. sash size 3 m²
- Max. sash weight 100 kg
- Ratio between sash rebate width : sash rebate height ≤ 2:1

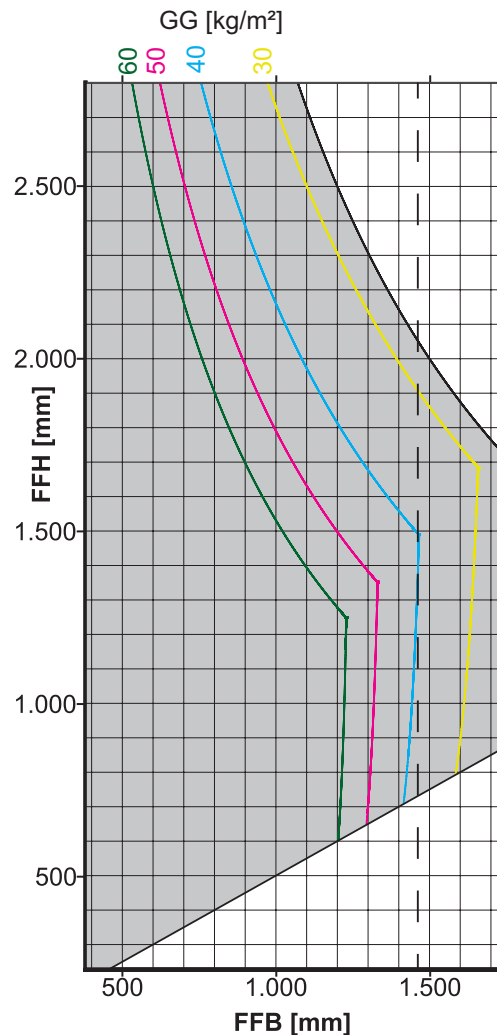

AWD_01.50_NR20_DK_100 kg_ohne_Zusatzlast_2_m

Abbreviations

- FFB = Sash rebate width [mm]
- FFH = Sash rebate height [mm]
- GG = Glass weight per square metre [kg/m²]
- ZSR = Additional shear
(section on right of interrupted line)

Observe instructions on window profile

You must specifically take into account information provided by the profile manufacturer or system owner when determining the maximum sash sizes and sash weights!



Important: The load-bearing fitting components, such as corner, shear and sash hinges, must be designed according to the TBDK guidelines. Please adapt the drill diameter of the fixing screws, the screw diameter and the screw length to the load situation.

activPilot Concept

Application diagram for ascertaining the admissible sash sizes

- maximum sash weight 130 kg

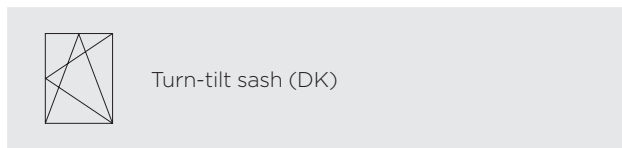
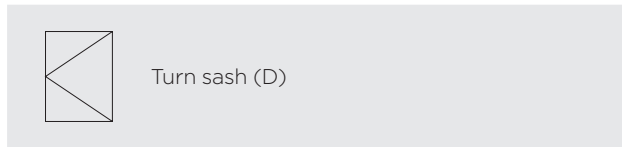
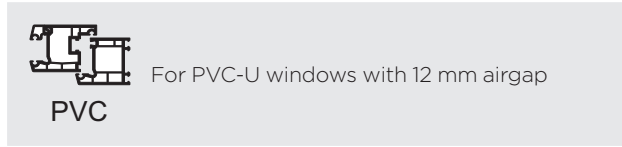

Width-to-height ratio and additional load

Value calculated without additional load for a width-to-height ratio of 2:1. The application diagrams have been established without considering additional loads. For ascertaining the max. sash sizes with additional loads, please ask your authorised contact partner for comprehensive advice!

Advice for use

The permissible application range for using Winkhaus fittings is marked grey in the application diagrams. However, please do not take into account the complete grey surface, but only the part which is on the left side of the “filling weight GG” curve.

Application range

All fittings must be selected from the original Winkhaus activPilot fitting component range. We accept no liability in case of use of third party or non-approved system components.

- Min. sash rebate width 270 mm
- Max. sash rebate width 1725 mm
- From 1475 mm sash rebate width with additional shear ZSR
- Min. sash rebate height 230 mm
- Max. sash rebate height 2,800 mm
- Max. sash size 3 m²
- Max. sash weight 130 kg
- Ratio between sash rebate width : sash rebate height ≤ 2:1

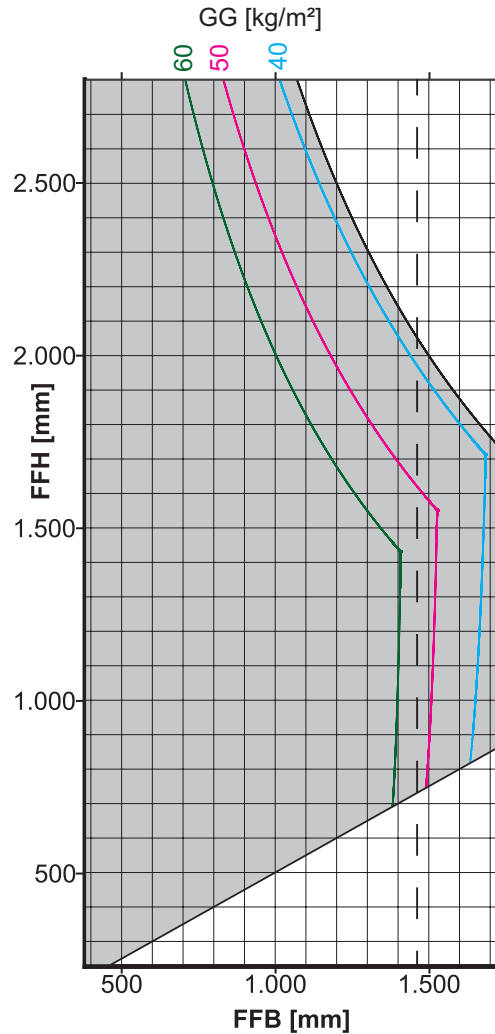

AWD_01.50_NR30_DK_130 kg_ohne_Zusatzlast_2_m

Abbreviations

- FFB = Sash rebate width [mm]
- FFH = Sash rebate height [mm]
- GG = Glass weight per square metre [kg/m²]
- ZSR = Additional shear (section on right of interrupted line)

Observe instructions on window profile

You must specifically take into account information provided by the profile manufacturer or system owner when determining the maximum sash sizes and sash weights!



Important: The load-bearing fitting components, such as corner, shear and sash hinges, must be designed according to the TBDK guidelines. Please adapt the drill diameter of the fixing screws, the screw diameter and the screw length to the load situation.

1

Further products

activPilot Select

The fully concealed turn-tilt fitting system.

The fitting system features fully concealed shear, turn and corner hinges housed in the rebate. When installed as a standard model, this elegantly designed turn and tilt fitting is able to bear sashes weighing up to 100 kg. With just two additional components, it can easily support sashes weighing up to 150 kg.



activPilot Topstar

Fully-concealed turn-tilt fittings for design windows.

The activPilot Topstar system enables you to build windows with particularly aesthetic demands and sash weights up to 130 kg. The optimised control curve of the hinge parts enables a narrow shadow joint for flush windows and a small free size of the frame for offset profiles.



activPilot Comfort

The fitting system with parallel action

Allround security thanks to innovative technology. The convenient approach to a healthy indoor atmosphere and improved illegal entry protection in parallel position.



duoPort SK

Slide-tilt fittings.

The slide-tilt doors delivered with the duoPort SK series support sash weights of up to 200 kg, with perfect functionality and elegant design. They can be operated conveniently by simply pressing the handle in combination with a pull-in shear device.



activPilot Control

Locking sensors up to VdS Class C.

Unobtrusive closing sensors reliably report which windows and glazed doors are open or locked. At the same time heating and air-conditioning controls are supported.



Winkhaus smartHome

Smart opening sensors with wireless technology

Smart home systems simplify everyday life, providing convenience for your own house. Thanks to the radio contacts from the Winkhaus smartHome product range it is possible to detect the locked and open state of windows. The signal is wirelessly conveyed to a smart home system for evaluation or control. As an option the signal can be conveyed to an intrusion detection system by means of a wireless switching relay. An integration of radio contacts offers the special advantage of foregoing time-consuming cable work and is hence ideally suited for retrofitting intrusion detection systems. Windows can now be entirely integrated into the smart home. It goes without saying that Winkhaus locking sensors have received the VdS Home approval and they are protected according to IP 67.



1

Packing key in the Winkhaus logistics system

The shipping units were chosen in a way that our products can be handled without any problems at your works, ranging from cardboard packaging to complete pallet units. For instance, we provide KLTs (small load carriers) in different sizes which are eco-friendly and facilitate logistics. The reusable packaging units, which can be stacked on a europallet, have a bar code and enable optimal stock organisation and easy transport to the relevant workstations. The packaging used for the products in question can be found on the corresponding product pages.



BL Goods packed in PE bags with bar code



KT Goods packed in cardboard boxes with bar code



BD Tied goods with barcode



K3 K3 Small cardboard box with bar code Dim.: 395 x 295 x 205 mm

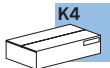

K4 K4 Big cardboard box with bar code Dim: 595 x 395 x 205 mm



KK KK Small KLT 4321 Dim: 400 x 300 x 214 mm with cover, bar code, sealed, stackable



GK GK Big KLT 6412 Dim: 600 x 400 x 214 mm with cover, bar code, sealed, stackable

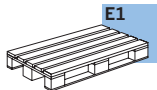

E1 E1 europallet with KLT Pallet size 800 x 1,200 mm

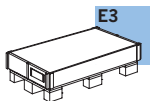

E3 E3 One-way pallet with cover box and bar code

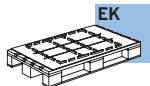

EK EK Europallet with KLT and fixing plate (avoids shifting of goods) Pallet size 800 x 1,200 mm

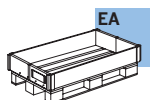

EA EA Europallet with frame and bar code Pallet size 800 x 1,200 mm

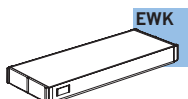

EWK EWK Disposable cardboard box E3, L6 or L7

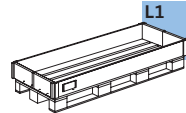

L1 L1 Reusable pallet for long goods with frame and bar code Pallet size 800 x 1,800 mm

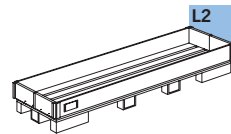

L2 L2 Reusable pallet II for long goods with frame and bar code Pallet size 800 x 2,400 mm

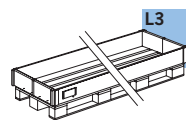

L3 L3 Reusable pallet III for long goods with frame and bar code Pallet size 800 x 3,500 mm

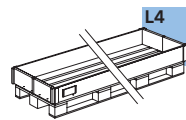

L4 L4 Reusable pallet IV for long goods with frame and bar code Pallet size 800 x 4,200 mm

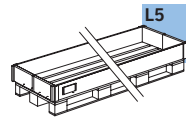

L5 L5 Reusable pallet V for long goods with frame and bar code Pallet size 800 x 6,500 mm

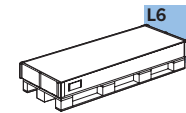

L6 L6 One-way pallet with cover box for long goods with bar code Pallet size 800 x 1,800 mm

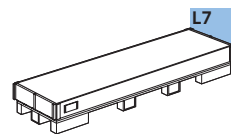

L7 L7 One-way pallet with cover box for long goods with bar code Pallet size 800 x 2,400 mm

Glossary

1

Code

AB.G.D	Drilling protection	HFG	Window Handle Case HFG
ADP	Adapter	HT	Timber windows, pot hinge version
AKR	Automatic shootbolt	HW	Timber windows, rebate version
AL...	Support plate		
AP...SE	Adapter plate, activPilot Select	IF	activPilot Topstar
AS.DSL	Mini ventilation unit (turn position)		
AS.SBA	Mini vent keep	K.EL	Corner hinge cap
ASP ER-A	End plate	K.FL	Sash hinge cover
ASS AR	Corner drive	K.SB	Shear hinge cap, timber
AWDR	Blocking plate	K.SK	Shear band cap
		K.SL	Shear hinge cover
		KB	Tilt hinge
BDT	Motor drive of the fitting system	KBG	Tilt limiter
BK	Balcony door catch	KE	Coupling element
BK.KR	Catch bolt	KLB	Tilt hinge
BO	Catch bolt	KR	Shootbolt
BS	Ground sill	KUE-T1	Cable transition, separable
BST AP/FS	Punch		
D	Backset	LE.B	Drilling jig
DB	Turn limiter	LE.N	Jig
DFE	Dual function element	LIN AP/FS	Ruler of fittings press
DL	Turn hinges	LM-RG	Round handle
DL...ET	Turn hinge, 1 piece		
DLW ERW	Top hinge bracket	M	Interlocking rod
DML	Turn middle hinge	MK	Interlocking rod, extendable
DS	Window lock	MS.SO	Interlocking rod, double sash, keep top
		MS.SU	Interlocking rod, double sash, keep bottom
		MSL.OS	Variable tilt device top rod
E	Corner drive		
E1.A	Corner drive for studio windows	OBV	Opening limiter
E1.MSL	Corner drive with variable tilt device	OS	Top rod
E1.SBS	Corner drive for double-sash window	OS...PA...	Top rod, PADK
EL	Corner hinge	OS. ...E	Top rod (turn before tilt)
EL.KB	Corner hinge up to 130 kg	OS.A	Screw clip
ESV	Corner hinge ESV		
ESVW	Corner hinge (up to 130 kg)		
FBP	Window limiter	PA	Parallel action
FH ...	Sash lifter	PAD	Parallel action, turn
FL	Sash hinge	PADK	Parallel action, turn-tilt
FL.E.FK.PADS	Sash hinge, PADS		
FL.E.FPAD	Sash hinge PAD	RA.DB...SE	Frame connection turn limiter, activPilot Select
FL.E.FWPA	Sash hinge, PADK	RT.DFE-TFE	Frame part, dual/triple function element
FLS.SE	Sash hinge rail, activPilot Select	RT.DFE-TFE.S	Frame part, dual/triple function element, double-sash windows
FSA	Fail safe device FSA		
FSF	Fail safe device FSF	RT.MSL	Frame part, variable tilt device
FSR	Rebate shear		
FT	Adapter		
FWV	Sash hinge, rebate hinge		
GAK	Drive rod, constant handle position		
GAKA	Drive rod, constant handle position, lockable		
GAM	Drive rod, central handle position		
GAMA	Drive rod, central handle position, lockable		
GASK	Double sash drive rod, constant handle position		
GASM	Double sash drive rod, central handle position		
GAVM	Locking drive rod activPilot, central handle position		
GG	Handle set		
GK	Constant handle position		
GRT.RB	Round arch set		

Item description









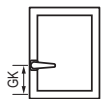

S.FL	Sash hinge plug	...LS	Fitting direction left
SA	Run-up block	...RS	Fitting direction right
SB SZV	Keep, pull-in device	...AGR	anthracite grey (similar to RAL 7016)
SBA...	Keep, contact pressure	...BR	brown (similar to RAL 8019)
SBA...T	Mini vent keep	...BZ-AM	bronze - antique brass
SBK	Security tilt keep	...BZ-CU	bronze - coppery
SBK...E	Tilt keep (tilt before turn)	...BZ-RB	bronze - red brown
SBK...PA	Tilt keep (with slider), PADK	...CW	creme white (similar to RAL 9001)
SBS...	Security keep	...EV1	anodised silver
SBS...PAB	Security keep PAB, PADK	...F1	silver coloured
SBS...PAD	Security keep PAD	...F1 anodised	(similar to F1) anodised silver
SE	activPilot Select	...F3	gold coloured
SH...T	Shear, pot hinge	...F3-MG	gold mat
SK	Shear, rebate hinge	...F9	titanium coloured
SK...PA	Shear, PADK	...LBR	clay brown
SK...PAD	Shear PAD	...PW	pearl white (similar to RAL 1013)
SK ... A	Shear studio window	...SG	silver-grey (similar to RAL 7001)
SK ... E	Shear (tilt before turn)	...SGB	grey (similar to RAL 9006)
SKK	Shear, without turn restriction	...SGR	grey (similar to RAL 7037)
SL	Shear hinge	...SL	silver look (zinc galvanised)
SL.HW	Shear hinge, rebate hinge	...SW	jet black
SLK	Shear hinge cap, rebate hinge	...WS	white (similar to RAL 9016)
SNH	Faceplate fastener		
SP R	Faceplate		
SR	Control unit		
SZP	Geared cover plate		
TFE	Triple function element		
V	Distance between locking points		
V.AK	Extension rod		
VS R	Connection rod		
VS RB	Connection rod round-arch window		
XL	Components from activPilot Giant range		
ZSR	Additional shear		
ZSRE	Additional shear (tilt before turn)		
ZSS.OS	Anti-slam device, top rod		
ZV.FT	Pull-in device, sash part		
ZV.RT	Pull-in device, frame part		

Overview of min. dimensions for drive rods D = 15.5 mm













The following overview shows the applications supported by corner drives. Use depends on the variant “turn-tilt” or “turn double sash”, and the window size. Depending on the application, other elements can be used as alternatives to corner drives.

Turn-tilt type, constant, single sash











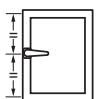

				
	270 - 370	371 - 600	601 - max	
230 - 325				
326 - 420				
421 - max				

Turn/Turn-tilt double sash type, constant

				
	280 - max	371 - 600	601 - max	
230 - 450				230 - 450
451 - 545	GASK			451 - max
546 - max				















Turn-tilt type, central, single sash



				
	270 - 370	371 - 600	601 - max	
230 - 325		GAK 465 G=114	GAK 465 G=114	
326 - 510				
511 - max				

E1 | E2 | E3 | KR

Turn/Turn-tilt double sash type, central

				
	280 - max	371 - 600	601 - max	
230 - 410		GAK 465 G=114	GAK 465 G=114	230 - 410
411 - 560	GASM			411 - 560
561 - 710				561 - max
711 - 980	GASM 1050			
981 - max				





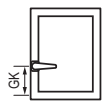

1

Overview of min. dimensions for drive rods D = 7.5 mm

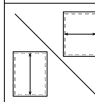
The following overview shows the applications supported by corner drives. Use depends on the variant "turn-tilt" or "turn double sash", and the window size. Depending on the application, other elements can be used as alternatives to corner drives.

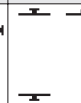
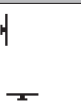
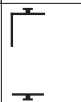

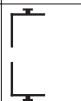



Turn-tilt type, constant, single sash

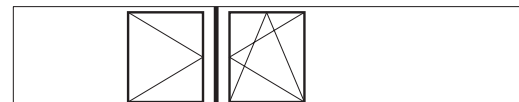

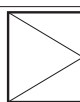
				
	270 - 370	371 - 600	601 - max	
338 - 433				
434 - 530				
531 - max				

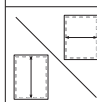
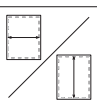
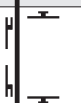
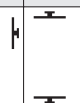

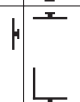





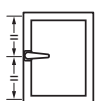

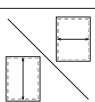
Turn/Turn-tilt double sash type, constant

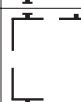

				
	280 - max	371 - 600	601 - max	
338 - 450				338 - 450
451 - 545	GASK 830			451 - 545
546 - max				546 - max

Turn-tilt type, central, single sash









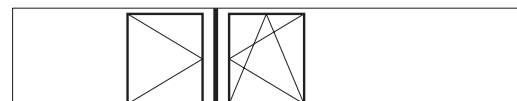

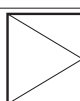
				
	270 - 370	371 - 600	601 - max	
381 - 574				
575 - 710				
711 - max				

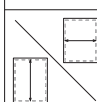
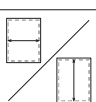
E1 E2 E3 KR

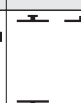
Turn/Turn-tilt double sash type, central

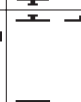

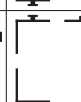
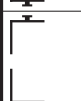
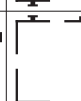
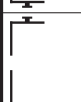
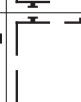

				
	280 - max	371 - 600	601 - max	
381 - 410				381 - 410
411 - 574				411 - 574
575 - 710				575 - 710
711 - 980	GASM 1050			711 - 980
981 - max				981 - max

Overview of max. dimensions for drive rods D = 15.5 and 7.5 mm





This overview shows how the gear side is designed when tall windows up to 2,725/2,800 mm are involved. The maximum sash height depends on the position of the window handle, central or constant.

Turn-tilt type, constant, single sash





		min - max*
2226 - 2475	MK.250-1 + GAK.2225-...	
2476 - 2725	MK.500-1 + GAK.2225-...	

Turn/Turn-tilt double sash type, constant





			
	min - max*	min - max*	
2226 - 2475	MS.SO.250-1 + GASK.2225-...	MK.250-1 + GAK.2225-...	2226 - 2475
2476 - 2725	MS.SO.500-1 + GASK.2225-...	MK.500-1 + GAK.2225-...	2476 - 2725

Turn-tilt type, central, single sash



		min - max*
2301 - 2800	MK.250-1 + GAM.2300-3 + MK.250-1	

Turn/Turn-tilt double sash type, central

			
	min - max*	min - max*	
2301 - 2800	MS.SO.250-1 + GASM.2300-3 + MS.SU.250-1	MK.250-1 + GAM.2300-3 + MK.250-1	2301 - 2800

* Please observe the "Diagrams to determine permissible sash sizes"!

Turn-tilt fitting - central handle position

Basic equipment

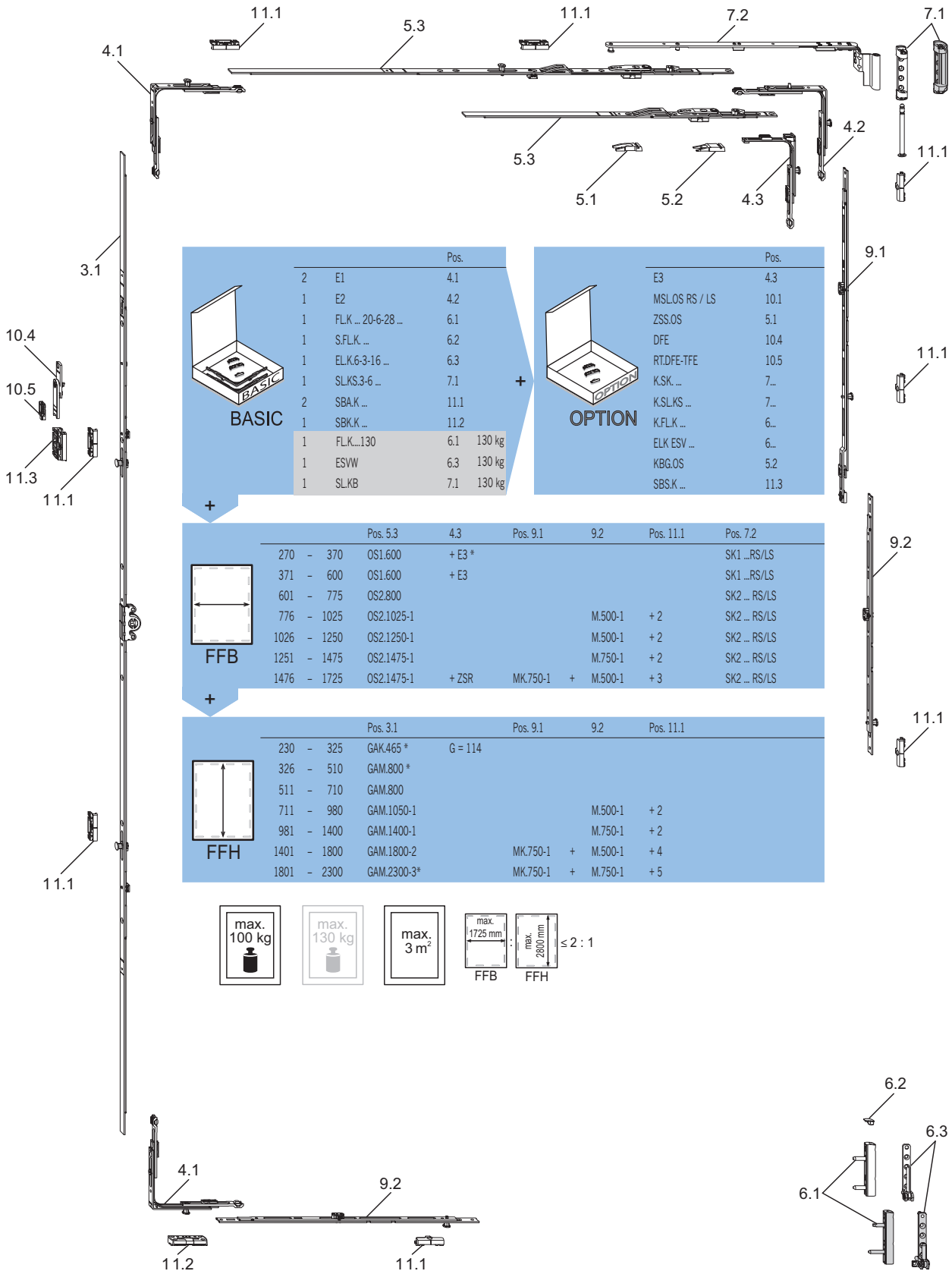
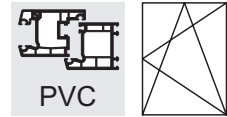

BASIC			Pos.
2	E1		4.1
1	E2		4.2
1	FLK... 20-6-28...		6.1
1	S.FLK...		6.2
1	ELK.6-3-16...		6.3
1	SLKS.3-6...		7.1
2	SBAK...		11.1
1	SBK.K...		11.2
1	FLK...130	130 kg	6.1
1	ESVW	130 kg	6.3
1	SLKB	130 kg	7.1

OPTION			Pos.
E3			4.3
MSLOS RS / LS			10.1
ZSS.OS			5.1
DFE			10.4
RT.DFE-TFE			10.5
K.SK...			7...
K.SLKS...			7...
K.FLK...			6...
ELK.ESV...			6...
KBG.OS			5.2
SBS.K...			11.3

FFB						
	Pos. 5.3	4.3	Pos. 9.1	9.2	Pos. 11.1	Pos. 7.2
270 - 370	OS1.600	+ E3 *				SK1...RS/LS
371 - 600	OS1.600	+ E3				SK1...RS/LS
601 - 775	OS2.800					SK2...RS/LS
776 - 1025	OS2.1025-1			M.500-1	+ 2	SK2...RS/LS
1026 - 1250	OS2.1250-1			M.500-1	+ 2	SK2...RS/LS
1251 - 1475	OS2.1475-1			M.750-1	+ 2	SK2...RS/LS
1476 - 1725	OS2.1475-1	+ ZSR	MK.750-1	+ M.500-1	+ 3	SK2...RS/LS

FFH					
	Pos. 3.1	Pos. 9.1	9.2	Pos. 11.1	
230 - 325	GAK.465 *	G = 114			
326 - 510	GAM.800 *				
511 - 710	GAM.800				
711 - 980	GAM.1050-1		M.500-1	+ 2	
981 - 1400	GAM.1400-1		M.750-1	+ 2	
1401 - 1800	GAM.1800-2		MK.750-1	+ M.500-1	+ 4
1801 - 2300	GAM.2300-3*		MK.750-1	+ M.750-1	+ 5

max.
100 kg

max.
130 kg

max.
3 m²

max.
1725 mm
FFB

max.
2800 mm
FFH

≤ 2 : 1

* See overview Min/max. dimensions
Please pay attention to the application diagrams!

Turn-tilt fitting - constant handle position

Suitable for burglary-resistant windows WK1 / RC1 N

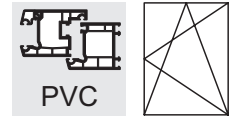

2

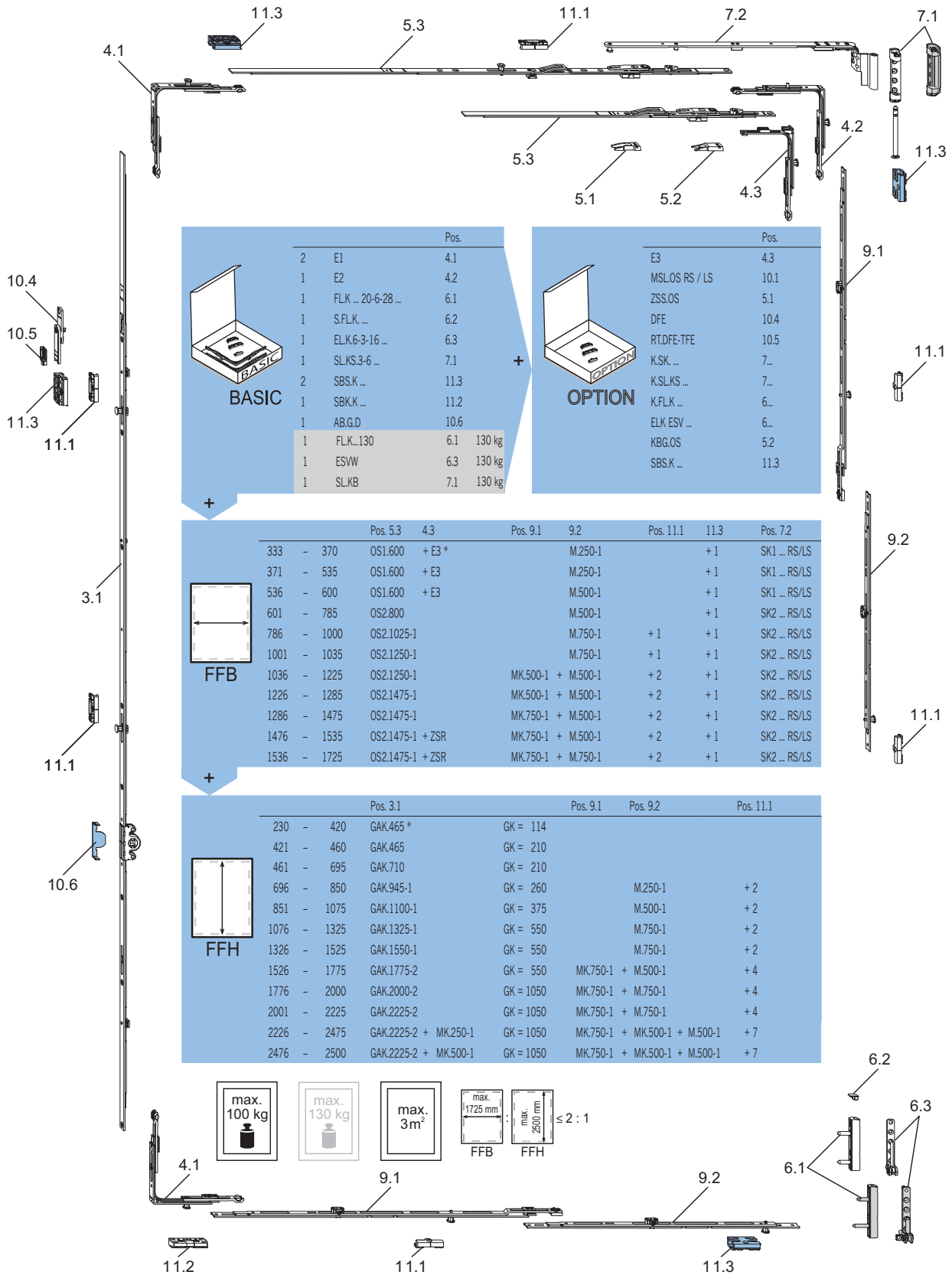

* See overview min. dimensions

Please pay attention to the application diagrams!

For further information please contact your Winkhaus representative.

Turn-tilt fitting - central handle position

Suitable for burglary-resistant windows WK1 / RC1 N

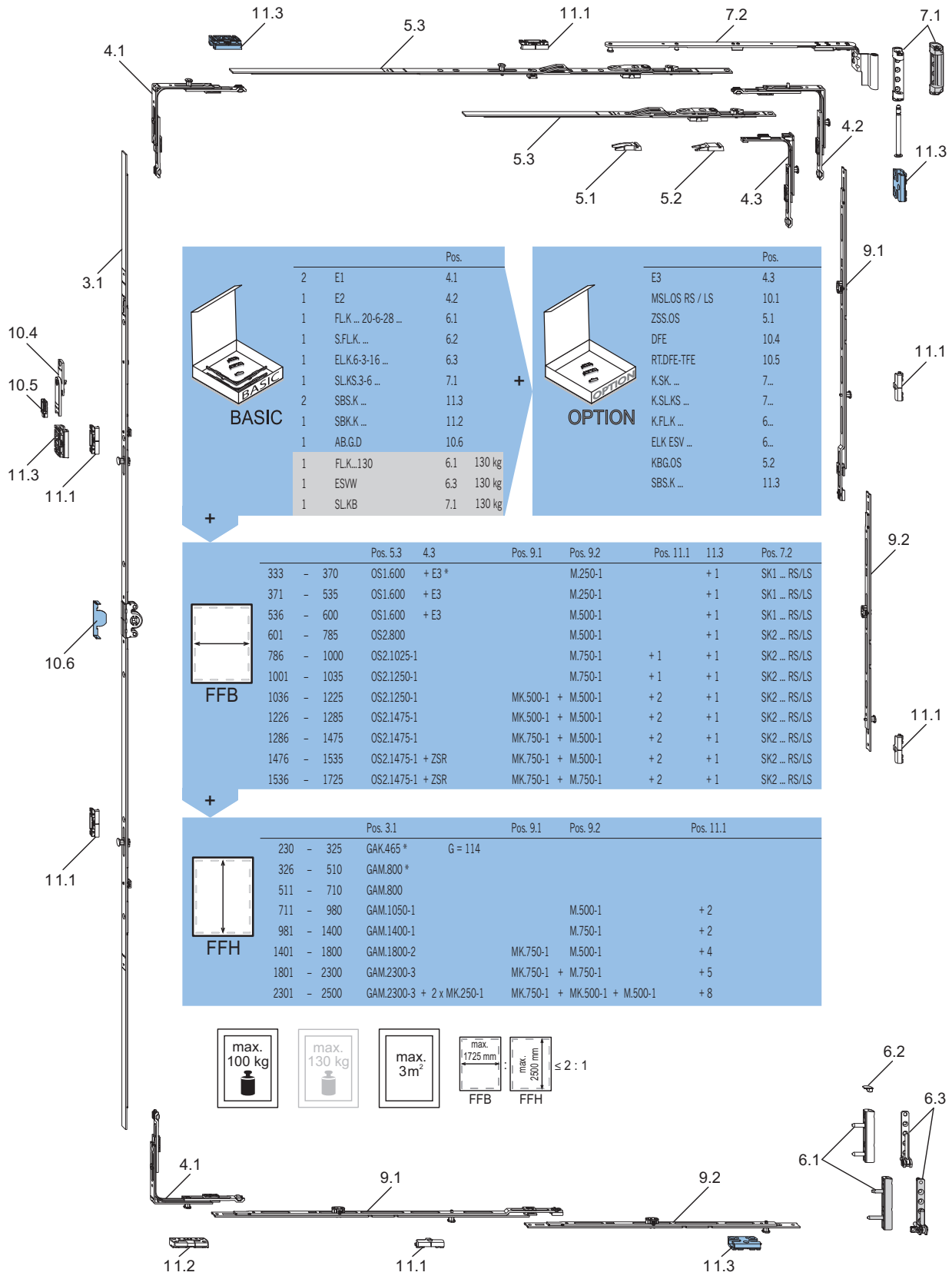
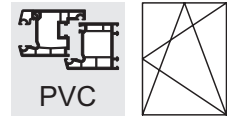

BASIC		Pos.
2	E1	4.1
1	E2	4.2
1	FLK ... 20-6-28 ...	6.1
1	S.FLK ...	6.2
1	ELK.G-3-16 ...	6.3
1	SLKS.3-6 ...	7.1
2	SBS.K ...	11.3
1	SBK.K ...	11.2
1	AB.G.D	10.6
1	FLK...130	6.1 130 kg
1	ESVW	6.3 130 kg
1	SLKB	7.1 130 kg

OPTION		Pos.
E3		4.3
MSLOS RS / LS		10.1
ZSS.OS		5.1
DFE		10.4
RT.DFE-TFE		10.5
K.SK ...		7...
K.SLKS ...		7...
K.FLK ...		6...
ELK ESV ...		6...
KBG.OS		5.2
SBS.K ...		11.3

	Pos. 5.3	4.3	Pos. 9.1	Pos. 9.2	Pos. 11.1	11.3	Pos. 7.2
333 - 370	OS1.600	+ E3 *		M.250-1		+ 1	SK1 ... RS/LS
371 - 535	OS1.600	+ E3		M.250-1		+ 1	SK1 ... RS/LS
536 - 600	OS1.600	+ E3		M.500-1		+ 1	SK1 ... RS/LS
601 - 785	OS2.800			M.500-1		+ 1	SK2 ... RS/LS
786 - 1000	OS2.1025-1			M.750-1	+ 1	+ 1	SK2 ... RS/LS
1001 - 1035	OS2.1250-1			M.750-1	+ 1	+ 1	SK2 ... RS/LS
1036 - 1225	OS2.1250-1		MK.500-1 +	M.500-1	+ 2	+ 1	SK2 ... RS/LS
1226 - 1285	OS2.1475-1		MK.500-1 +	M.500-1	+ 2	+ 1	SK2 ... RS/LS
1286 - 1475	OS2.1475-1		MK.750-1 +	M.500-1	+ 2	+ 1	SK2 ... RS/LS
1476 - 1535	OS2.1475-1 + ZSR		MK.750-1 +	M.500-1	+ 2	+ 1	SK2 ... RS/LS
1536 - 1725	OS2.1475-1 + ZSR		MK.750-1 +	M.750-1	+ 2	+ 1	SK2 ... RS/LS

	Pos. 3.1	Pos. 9.1	Pos. 9.2	Pos. 11.1
230 - 325	GAK.465 *	G = 114		
326 - 510	GAM.800 *			
511 - 710	GAM.800			
711 - 980	GAM.1050-1		M.500-1	+ 2
981 - 1400	GAM.1400-1		M.750-1	+ 2
1401 - 1800	GAM.1800-2	MK.750-1	M.500-1	+ 4
1801 - 2300	GAM.2300-3	MK.750-1 +	M.750-1	+ 5
2301 - 2500	GAM.2300-3 + 2 x MK.250-1	MK.750-1 +	MK.500-1 + M.500-1	+ 8

max. 100 kg
 max. 130 kg
 max. 3m²
 max. 1725 mm
 max. 2500 mm
 ≤ 2 : 1

* See overview min. dimensions
 Please pay attention to the application diagrams!
 For further information please contact your Winkhaus representative.

Turn-tilt fitting - constant handle position

Suitable for burglary-resistant windows WK2 / RC2 / RC2 N

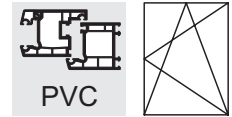

2

BASIC		Pos.
3	E1	4.1
1	E2	4.2
1	FLK ...	6.1
1	S.FLK ...	6.2
1	ELK.6-3-16 ...	6.3
1	SLKS.3-6 ...	7.1
3	SBS.K...	11.3
1	SBK.K ...	11.2
1	AB.G.D	10.6
1	FL.K..130	6.1 130 kg
1	ESVW	6.3 130 kg
1	SLKB	7.1 130 kg

OPTION		Pos.
E3		4.3
MSL.OS RS / LS		10.1
ZSS.OS		5.1
DFE		10.4
RT.DFE-TFE		10.5
K.SK ...		7...
K.SLKS ...		7...
K.FLK ...		6...
ELK ESV ...		6...
KBG.OS		5.2

	Pos. 5.3	4.3	Pos. 9.1	Pos. 9.3	Pos. 11.3	Pos. 7.2
460 - 600	OS1.600	+ E3		KE		SK1 ... RS/LS
601 - 710	OS2.800			KE		SK2 ... RS/LS
711 - 775	OS2.800		MK.250-0	+ KE		SK2 ... RS/LS
776 - 960	OS2.1025-1		MK.250-1	+ KE	+ 2	SK2 ... RS/LS
961 - 1025	OS2.1025-1		MK.500-1	+ KE	+ 2	SK2 ... RS/LS
1026 - 1210	OS2.1250-1		MK.500-1	+ KE	+ 2	SK2 ... RS/LS
1211 - 1250	OS2.1250-1		MK.750-1	+ KE	+ 2	SK2 ... RS/LS
1251 - 1460	OS2.1025-1 + ZSR + MK250-1		MK.750-1	+ KE	+ 3	SK2 ... RS/LS
1461 - 1525	OS2.1025-1 + ZSR + MK250-1		2 x MK.500-1	+ KE	+ 4	SK2 ... RS/LS
1526 - 1710	OS2.1025-1 + ZSR + MK500-1		2 x MK.500-1	+ KE	+ 4	SK2 ... RS/LS

	Pos. 3.1	Pos. 9.1	Pos. 9.2	Pos. 9.2	Pos. 11.3
420 - 460	GAK.465	GK = 210			
461 - 580	GAK.710	GK = 210			
581 - 695	GAK.830-1	GK = 260	M.250-1		2
696 - 850	GAK.945-1	GK = 260	M.500-1		2
851 - 1000	GAK.1100-1	GK = 375	M.500-1		2
1001 - 1075	GAK.1100-1	GK = 375	M.750-1		2
1076 - 1200	GAK.1325-2	GK = 550	M.750-1		3
1201 - 1325	GAK.1325-2	GK = 550	MK.500-1	M.500-1	4
1326 - 1500	GAK.1550-2	GK = 550	MK.500-1	M.500-1	4
1501 - 1525	GAK.1550-2	GK = 550	MK.750-1	M.500-1	4
1526 - 1750	GAK.1775-2	GK = 550	MK.750-1	M.500-1	4
1751 - 1775	GAK.1775-2	GK = 550	MK.750-1	M.750-1	4
1776 - 2000	GAK.2000-2	GK = 1050	MK.750-1	M.750-1	4
2001 - 2225	GAK.2225-2	GK = 1050	MK.750-1	MK.500-1 M.500-1	5
2226 - 2250	GAK.2225-2 + MK.250-1	GK = 1050	MK.750-1	MK.500-1 M.500-1	5
2251 - 2475	GAK.2225-2 + MK.250-1	GK = 1050	MK.750-1	MK.750-1 M.500-1	5
2476 - 2500	GAK.2225-2 + MK.500-1	GK = 1050	MK.750-1	MK.750-1 M.500-1	6

max. 100 kg

max. 130 kg

max. 3m²

max. 1710 mm

max. 2500 mm

FFB FFH ≤ 2 : 1

The processing details RC2 can be gathered from the RC2 system tests. The RC2 fitting lists in this catalogue are only application examples. Please turn to your Winkhaus contact person.

Turn-tilt fitting - central handle position

Suitable for burglary-resistant windows WK2 / RC2 / RC2 N

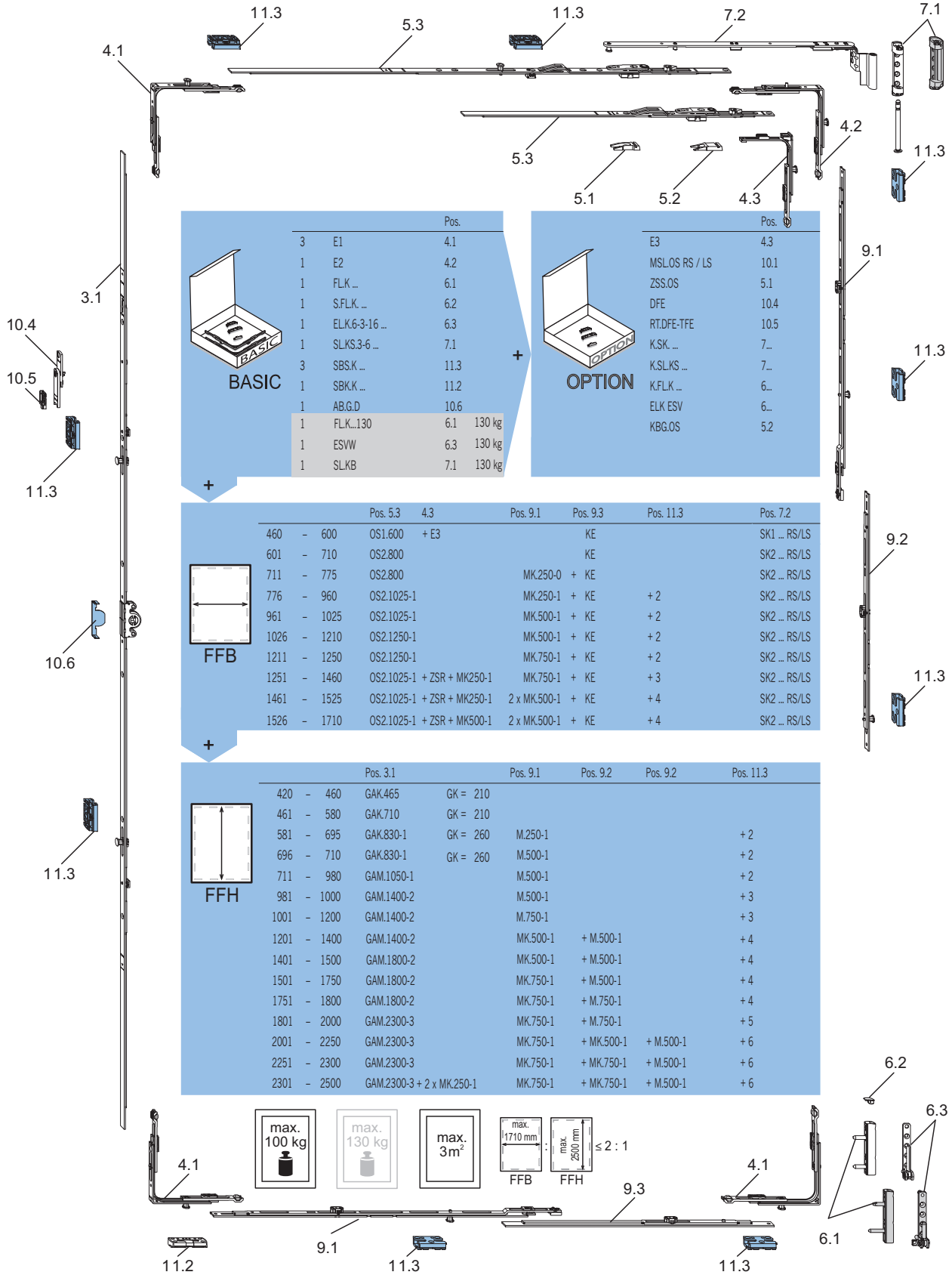
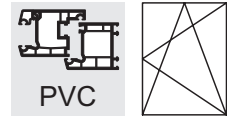

The processing details RC2 can be gathered from the RC2 system tests. The RC2 fitting lists in this catalogue are only application examples. Please turn to your Winkhaus contact person.

Turn-tilt fitting - constant handle position

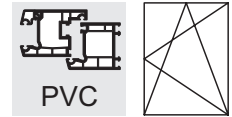

Basic equipment
Backset 7.5 mm

2

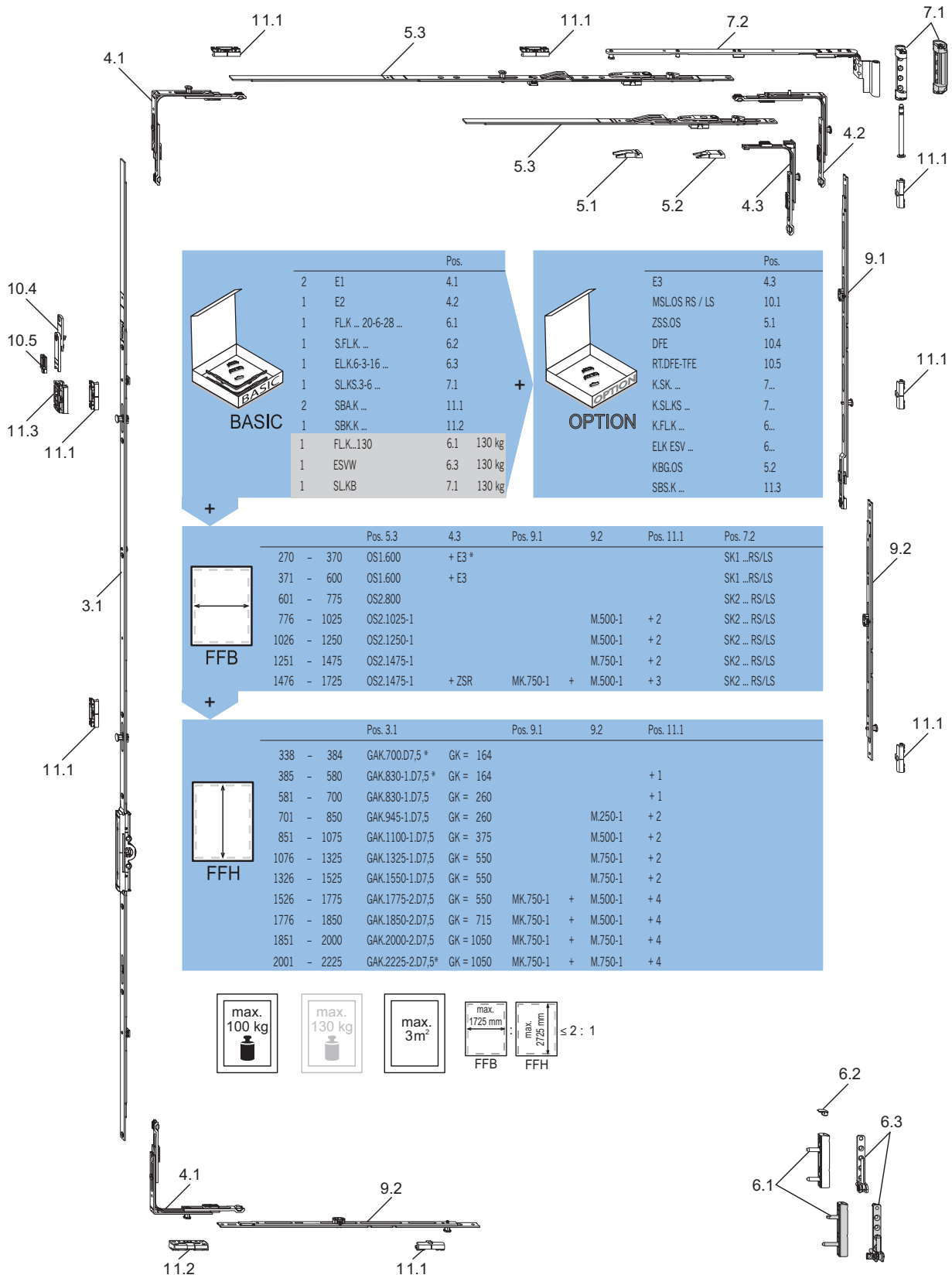

BASIC		
		Pos.
2	E1	4.1
1	E2	4.2
1	FLK ... 20-6-28 ...	6.1
1	S.FLK ...	6.2
1	ELK 6-3-16 ...	6.3
1	SLKS 3-6 ...	7.1
2	SBAK ...	11.1
1	SBKK ...	11.2
1	FLK...130	6.1 130 kg
1	ESVW	6.3 130 kg
1	SLKB	7.1 130 kg

OPTION		
		Pos.
E3		4.3
MSLOS RS / LS		10.1
ZSS.OS		5.1
DFE		10.4
RT.DFE-TFE		10.5
K.SK ...		7...
K.SLKS ...		7...
K.FLK ...		6...
ELK ESV ...		6...
KBG.OS		5.2
SBS.K ...		11.3

FFB		Pos. 5.3	4.3	Pos. 9.1	9.2	Pos. 11.1	Pos. 7.2
270 - 370	OS1.600		+ E3 *				SK1 ...RS/LS
371 - 600	OS1.600		+ E3				SK1 ...RS/LS
601 - 775	OS2.800						SK2 ...RS/LS
776 - 1025	OS2.1025-1				M.500-1	+ 2	SK2 ...RS/LS
1026 - 1250	OS2.1250-1				M.500-1	+ 2	SK2 ...RS/LS
1251 - 1475	OS2.1475-1				M.750-1	+ 2	SK2 ...RS/LS
1476 - 1725	OS2.1475-1		+ ZSR	MK.750-1	+ M.500-1	+ 3	SK2 ...RS/LS

FFH		Pos. 3.1	Pos. 9.1	9.2	Pos. 11.1
338 - 384	GAK.700.D7,5 *	GK = 164			
385 - 580	GAK.830-1.D7,5 *	GK = 164			+ 1
581 - 700	GAK.830-1.D7,5	GK = 260			+ 1
701 - 850	GAK.945-1.D7,5	GK = 260		M.250-1	+ 2
851 - 1075	GAK.1100-1.D7,5	GK = 375		M.500-1	+ 2
1076 - 1325	GAK.1325-1.D7,5	GK = 550		M.750-1	+ 2
1326 - 1525	GAK.1550-1.D7,5	GK = 550		M.750-1	+ 2
1526 - 1775	GAK.1775-2.D7,5	GK = 550	MK.750-1	+ M.500-1	+ 4
1776 - 1850	GAK.1850-2.D7,5	GK = 715	MK.750-1	+ M.500-1	+ 4
1851 - 2000	GAK.2000-2.D7,5	GK = 1050	MK.750-1	+ M.750-1	+ 4
2001 - 2225	GAK.2225-2.D7,5*	GK = 1050	MK.750-1	+ M.750-1	+ 4

max.
100 kg

max.
130 kg

max.
3m²

max.
1725 mm
FFB

max.
2725 mm
FFH

≤ 2 : 1

* See overview Min/max. dimensions
Please pay attention to the application diagrams!

Turn double sash fitting - constant handle position

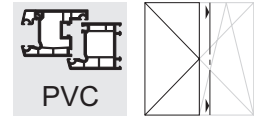

Basic equipment

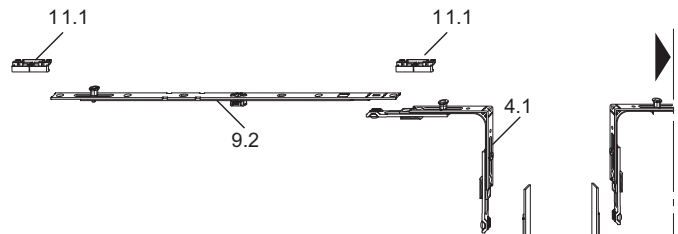
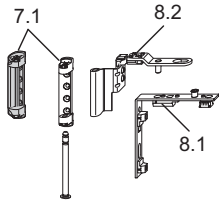

BASIC			OPTION		
		Pos.			Pos.
2	E1	4.1	K.SK ...		7...
1	FLK ... 20-6-28 ...	6.1	K.SLKS ...		7...
1	S.FLK ...	6.2	K.FLK ...		6...
1	ELK 6-3-16 ...	6.3	ELK ESV		6...
1	SLKS.3-6	7.1	RT.DFE-TFES		10.6
1	DLW ERW	8.1	FH ...		11.5
1	DLK	8.2			
2	SBAK ...	11.1			
1	FLK...130	6.1	130 kg		
1	ESWW	6.3	130 kg		
1	SLKB	7.1	130 kg		

FFB	Pos. 9.1	9.2	Pos. 11.1
280 - 700			
701 - 1200	2 x	M.500-1	+ 2
1201 - 1450	2 x	M.750-1	+ 2
1451 - 1725	2 x	MK.500-1 + M.500-1	+ 4

FFH	Pos. 3.1	Pos. 9.3	11.4
461 - 545	GASK.710 *		
546 - 695	GASK.710		
696 - 850	GASK.945-1	1 x ZV-FT	+ ZV-RT ...
851 - 1075	GASK.1100-1	1 x ZV-FT	+ ZV-RT ...
1076 - 1325	GASK.1325-1	1 x ZV-FT	+ ZV-RT ...
1326 - 1525	GASK.1550-1	1 x ZV-FT	+ ZV-RT ...
1526 - 1775	GASK.1775-2	2 x ZV-FT	+ ZV-RT ...
1776 - 2000	GASK.2000-2	2 x ZV-FT	+ ZV-RT ...
2001 - 2225	GASK.2225-2*	2 x ZV-FT	+ ZV-RT ...

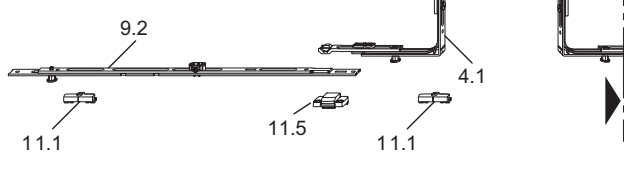
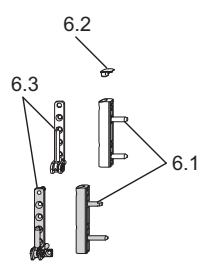
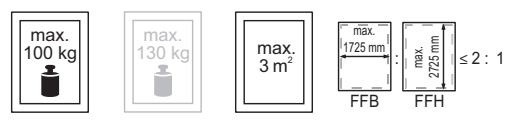

* See overview Min/max. dimensions
Please pay attention to the application diagrams!

Turn double-sash fitting - central handle position

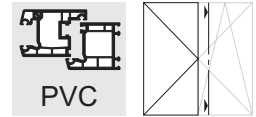

2

Basic equipment

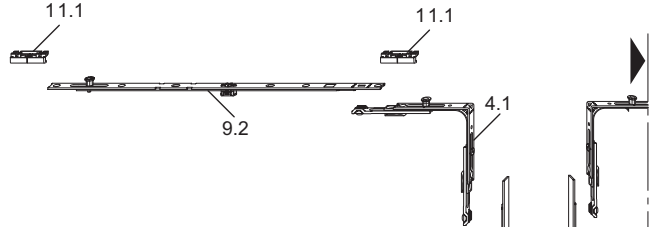
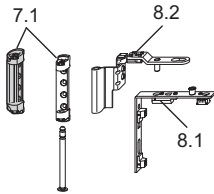

BASIC		Pos.	OPTION		Pos.
2	E1	4.1	K.SK ...	7...	7...
1	FLK ...20-6-28 ...	6.1	K.SLK.S ...	7...	7...
1	S.FLK ...	6.2	K.FLK ...	6...	6...
1	ELK.6-3-16 ...	6.3	ELK ESV	6...	6...
1	SLKS.3-6	7.1	RT.DFE-TFES	10.6	10.6
1	DLW ERW	8.1	FH ...	11.5	11.5
1	DLK	8.2			
2	SBAK ...	11.1			
1	FLK...130	6.1	130 kg		
1	ESVW	6.3	130 kg		
1	SLKB	7.1	130 kg		

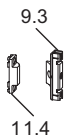

FFB	Pos. 9.1	9.2	Pos. 11.1
280 - 700			
701 - 1200	2 x	M.500-1	+ 2
1201 - 1450	2 x	M.750-1	+ 2
1451 - 1725	2 x	MK.500-1 + M.500-1	+ 4

FFH	Pos. 3.1	Pos. 9.3	11.4
410 - 560	GASM.800 *		
561 - 710	GASM.800 *		
711 - 980	GASM.1050.E3 *		
981 - 1400	GASM.1400-1	1 x ZV-FT	+ ZV-RT ...
1401 - 1800	GASM.1800-2	2 x ZV-FT	+ ZV-RT ...
1801 - 2300	GASM.2300-3*	2 x ZV-FT	+ ZV-RT ...

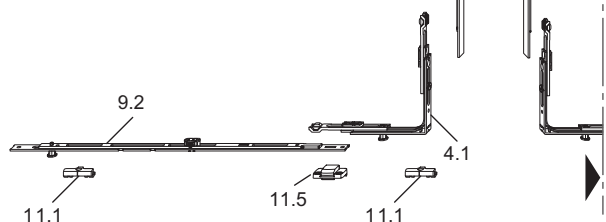
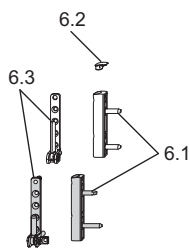
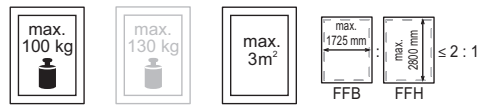

* See overview Min/max. dimensions
Please pay attention to the application diagrams!

Turn double sash fitting - constant handle position

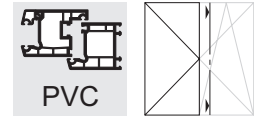

Suitable for burglary-resistant windows WK1 / RC1 N

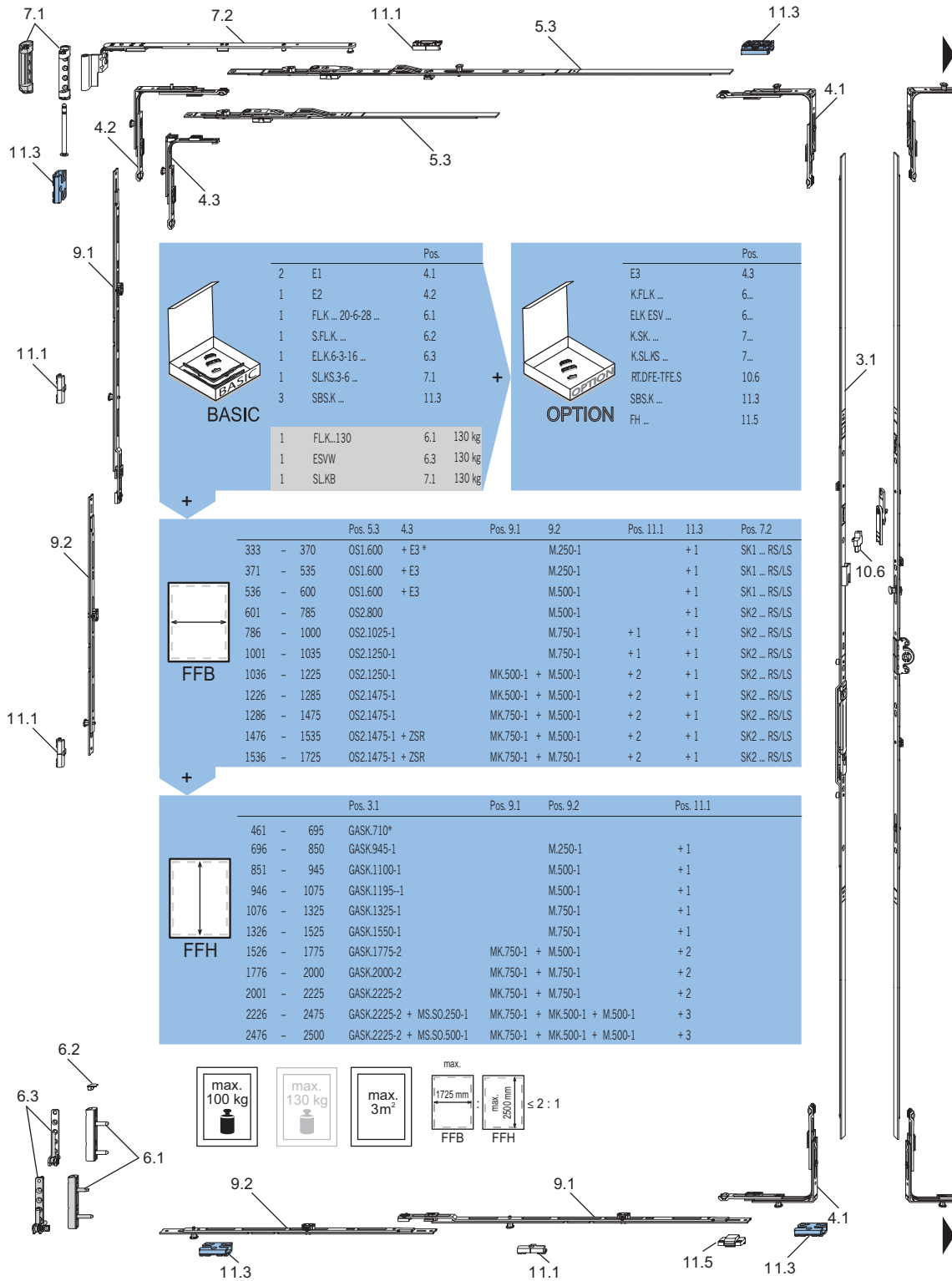

* See overview min. dimensions
 Please pay attention to the application diagrams!
 For further information please contact your Winkhaus representative.

Turn double-sash fitting - central handle position

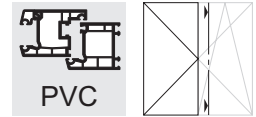

2

Suitable for burglary-resistant windows WK1 / RC1 N

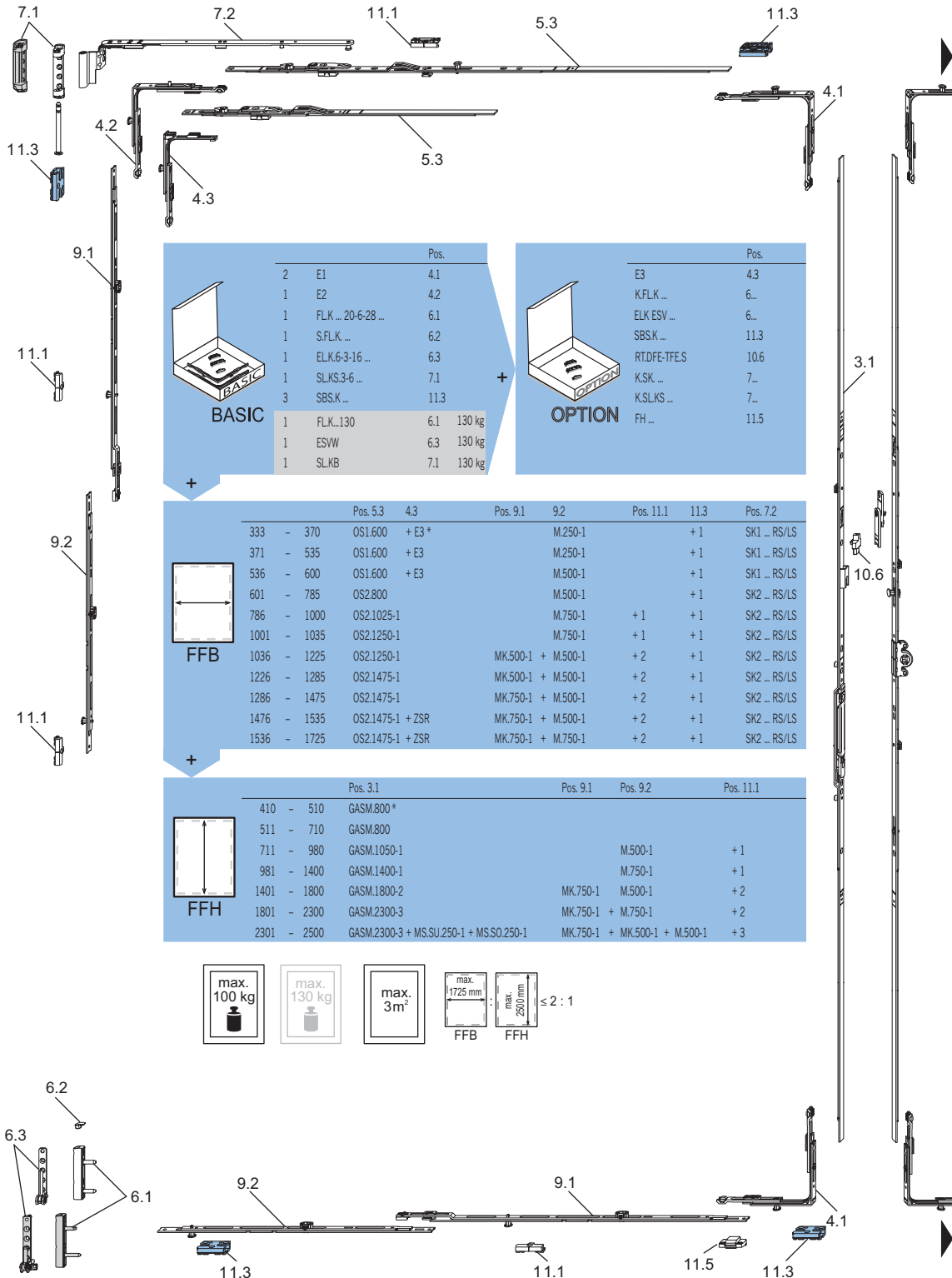

* See overview min. dimensions

Please pay attention to the application diagrams!

For further information please contact your Winkhaus representative.

Turn double sash fitting - constant handle position

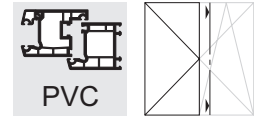

Suitable for burglary-resistant windows WK2 / RC2 / RC2 N

BASIC

		Pos.
3	E1	4.1
1	E2	4.2
1	FLK ...	6.1
1	S.FLK ...	6.2
1	ELK.6-3-16 ...	6.3
1	SLKS.3-6 ...	7.1
4	SBS.K ...	11.3

OPTION

		Pos.
	K.SK ...	7...
	K.SLKS ...	7...
	K.FLK ...	6...
	ELK ESV	6...
	RT.DFE-TFES	10.6
	FH ...	11.5

		Pos. 5.3	4.3	Pos. 9.1	9.3	Pos. 11.3	Pos. 7.2
460	- 600	OS1.600	+ E3				SK1 ... RS/LS
601	- 710	OS2.800					SK2 ... RS/LS
711	- 775	OS2.800		MK.250-0+ KE			SK2 ... RS/LS
776	- 960	OS2.1025-1		MK.250-1+ KE		+ 2	SK2 ... RS/LS
961	- 1025	OS2.1025-1		MK.500-1+ KE		+ 2	SK2 ... RS/LS
1026	- 1210	OS2.1250-1		MK.500-1+ KE		+ 2	SK2 ... RS/LS
1211	- 1250	OS2.1250-1		MK.750-1+ KE		+ 2	SK2 ... RS/LS
1251	- 1460	OS2.1025-1 + ZSR + MK250-1		MK.750-1+ KE		+ 3	SK2 ... RS/LS
1461	- 1525	OS2.1025-1 + ZSR + MK250-1		2 x MK.500-1+ KE		+ 4	SK2 ... RS/LS
1526	- 1710	OS2.1025-1 + ZSR + MK500-1		2 x MK.500-1+ KE		+ 4	SK2 ... RS/LS

		Pos. 3.1	Pos. 9.1	Pos. 9.2	Pos. 9.2	Pos. 11.3
450	- 580	GASK.710				
581	- 695	GASK.830-1	M.250-1			+ 1
696	- 850	GASK.945-1	M.500-1			+ 1
851	- 1000	GASK.1100-1	M.500-1			+ 1
1001	- 1075	GASK.1100-1	M.750-1			+ 1
1076	- 1200	GASK.1325-2	M.750-1			+ 1
1201	- 1325	GASK.1325-2	MK.500-1	M.500-1		+ 2
1326	- 1500	GASK.1550-2	MK.500-1	M.500-1		+ 2
1501	- 1525	GASK.1550-2	MK.750-1	M.500-1		+ 2
1525	- 1750	GASK.1775-2	MK.750-1	M.500-1		+ 2
1751	- 1775	GASK.1775-2	MK.750-1	M.750-1		+ 2
1776	- 2000	GASK.2000-2	MK.750-1	M.750-1		+ 2
2001	- 2225	GASK.2225-2	MK.750-1	MK.500-1	M.500-1	+ 3
2226	- 2250	GASK.2225-2 + MS.S0.250-1	MK.750-1	MK.500-1	M.500-1	+ 3
2251	- 2475	GASK.2225-2 + MS.S0.250-1	MK.750-1	MK.750-1	M.500-1	+ 3
2476	- 2500	GASK.2225-2 + MS.S0.500-1	MK.750-1	MK.750-1	M.500-1	+ 3

FFB

		Pos. 5.3	4.3	Pos. 9.1	9.3	Pos. 11.3	Pos. 7.2
460	- 600	OS1.600	+ E3				SK1 ... RS/LS
601	- 710	OS2.800					SK2 ... RS/LS
711	- 775	OS2.800		MK.250-0+ KE			SK2 ... RS/LS
776	- 960	OS2.1025-1		MK.250-1+ KE		+ 2	SK2 ... RS/LS
961	- 1025	OS2.1025-1		MK.500-1+ KE		+ 2	SK2 ... RS/LS
1026	- 1210	OS2.1250-1		MK.500-1+ KE		+ 2	SK2 ... RS/LS
1211	- 1250	OS2.1250-1		MK.750-1+ KE		+ 2	SK2 ... RS/LS
1251	- 1460	OS2.1025-1 + ZSR + MK250-1		MK.750-1+ KE		+ 3	SK2 ... RS/LS
1461	- 1525	OS2.1025-1 + ZSR + MK250-1		2 x MK.500-1+ KE		+ 4	SK2 ... RS/LS
1526	- 1710	OS2.1025-1 + ZSR + MK500-1		2 x MK.500-1+ KE		+ 4	SK2 ... RS/LS

FFH

		Pos. 3.1	Pos. 9.1	Pos. 9.2	Pos. 9.2	Pos. 11.3
450	- 580	GASK.710				
581	- 695	GASK.830-1	M.250-1			+ 1
696	- 850	GASK.945-1	M.500-1			+ 1
851	- 1000	GASK.1100-1	M.500-1			+ 1
1001	- 1075	GASK.1100-1	M.750-1			+ 1
1076	- 1200	GASK.1325-2	M.750-1			+ 1
1201	- 1325	GASK.1325-2	MK.500-1	M.500-1		+ 2
1326	- 1500	GASK.1550-2	MK.500-1	M.500-1		+ 2
1501	- 1525	GASK.1550-2	MK.750-1	M.500-1		+ 2
1525	- 1750	GASK.1775-2	MK.750-1	M.500-1		+ 2
1751	- 1775	GASK.1775-2	MK.750-1	M.750-1		+ 2
1776	- 2000	GASK.2000-2	MK.750-1	M.750-1		+ 2
2001	- 2225	GASK.2225-2	MK.750-1	MK.500-1	M.500-1	+ 3
2226	- 2250	GASK.2225-2 + MS.S0.250-1	MK.750-1	MK.500-1	M.500-1	+ 3
2251	- 2475	GASK.2225-2 + MS.S0.250-1	MK.750-1	MK.750-1	M.500-1	+ 3
2476	- 2500	GASK.2225-2 + MS.S0.500-1	MK.750-1	MK.750-1	M.500-1	+ 3

max. 100 kg

max. 130 kg

max. 3m²

max. 1710 mm FFB

max. 2500 mm FFH

≤ 2 : 1

The processing details RC2 can be gathered from the RC2 system tests. The RC2 fitting lists in this catalogue are only application examples. Please turn to your Winkhaus contact person.

Turn double-sash fitting - central handle position

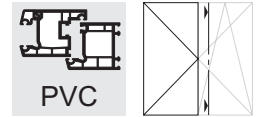

2

Suitable for burglary-resistant windows WK2 / RC2 / RC2 N

BASIC

		Pos.	
3	E1	4.1	
1	E2	4.2	
1	FLK...	6.1	
1	S.FLK...	6.2	
1	ELK.6-3-16...	6.3	
1	SLKS.3-6...	7.1	
4	SBS.K...	11.3	
1	FLK.130	6.1	130 kg
1	ESVW	6.3	130 kg
1	SLKB	7.1	130 kg

OPTION

		Pos.
	K.SK ...	7..
	K.SLKS ...	7..
	K.FLK ...	6..
	ELK ESV	6..
	RTDFE-TFES	10.6
	FH ...	11.5

FFB

		Pos. 5.3	4.3	Pos. 9.1	9.3	Pos. 11.3	Pos. 7.2
460 - 600	OS1.600	+ E3			KE		SK1 ... RS/LS
601 - 710	OS2.800				KE		SK2 ... RS/LS
711 - 775	OS2.800				MK.250-0+ KE		SK2 ... RS/LS
776 - 960	OS2.1025-1				MK.250-1+ KE	+ 2	SK2 ... RS/LS
961 - 1025	OS2.1025-1				MK.500-1+ KE	+ 2	SK2 ... RS/LS
1026 - 1210	OS2.1250-1				MK.500-1+ KE	+ 2	SK2 ... RS/LS
1211 - 1250	OS2.1250-1				MK.750-1+ KE	+ 2	SK2 ... RS/LS
1251 - 1460	OS2.1025-1 + ZSR + MK250-1				MK.750-1+ KE	+ 3	SK2 ... RS/LS
1461 - 1525	OS2.1025-1 + ZSR + MK250-1				2 x MK.500-1+ KE	+ 4	SK2 ... RS/LS
1526 - 1710	OS2.1025-1 + ZSR + MK500-1				2 x MK.500-1+ KE	+ 4	SK2 ... RS/LS

FFH

		Pos. 3.1	Pos. 9.1	Pos. 9.1	Pos. 9.2	Pos. 11.3	
460 - 580	GASK.710						
581 - 695	GASK.830-1				M.250-1	+ 1	
696 - 710	GASK.830-1				M.500-1	+ 1	
711 - 980	GASM.1050-1				M.500-1	+ 1	
981 - 1000	GASM.1400-2				M.500-1	+ 1	
1001 - 1200	GASM.1400-2				M.750-1	+ 1	
1201 - 1400	GASM.1400-2			MK.500-1	M.500-1	+ 2	
1401 - 1500	GASM.1800-2			MK.500-1	M.500-1	+ 2	
1501 - 1750	GASM.1800-2			MK.750-1	M.500-1	+ 2	
1751 - 1800	GASM.1800-2			MK.750-1	M.750-1	+ 2	
1801 - 2000	GASM.2300-3			MK.750-1	M.750-1	+ 2	
2001 - 2250	GASM.2300-3			MK.750-1	MK.500-1	M.500-1	+ 3
2250 - 2300	GASM.2300-3			MK.750-1	MK.750-1	M.500-1	+ 3
2301 - 2500	GASM.2300-3 + MS.S0.250-1 + MS.SU.250-1			MK.750-1	MK.750-1	M.500-1	+ 3

max. 100 kg

max. 130 kg

max. 3m²

max. 1710 mm

max. 2500 mm

FFB FFH ≤ 2 : 1

The processing details RC2 can be gathered from the RC2 system tests. The RC2 fitting lists in this catalogue are only application examples. Please turn to your Winkhaus contact person.

Turn double sash fitting - constant handle position

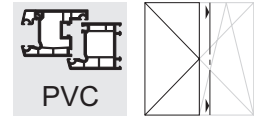

Basic equipment
Backset 7.5 mm

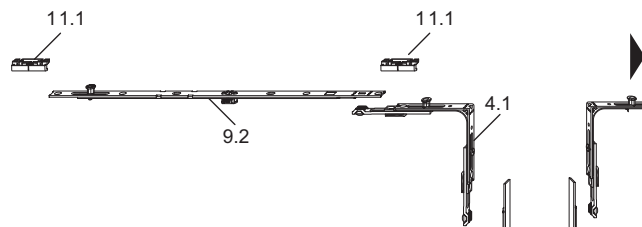
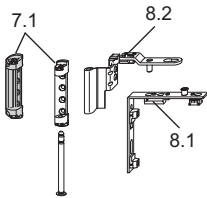

BASIC		Pos.	OPTION		Pos.
2	E1	4.1	K.SK ...	7...	7...
1	FLK ...20-6-28 ...	6.1	K.SLK.S ...	7...	7...
1	S.FLK ...	6.2	K.FLK ...	6...	6...
1	ELK.6-3-16 ...	6.3	ELK ESV	6...	6...
1	SLKS.3-6	7.1	RT.DFE-TFES	10.6	10.6
1	DLW ERW	8.1	FH ...	11.5	11.5
1	DLK	8.2			
2	SBAK ...	11.1			
1	FLK...130	6.1	130 kg		
1	ESVW	6.3	130 kg		
1	SLKB	7.1	130 kg		

FFB	Pos. 9.1	9.2	Pos. 11.1
280 - 700			
701 - 1200	2x	M.500-1	+ 2
1201 - 1450	2x	M.750-1	+ 2
1451 - 1725	2x	MK.500-1 + M.500-1	+ 4

FFH	Pos. 3.1	Pos. 9.3	11.4
335 - 485	KR711 *		
486 - 580	GASK.830-1 *		
581 - 700	GASK.830-1		
701 - 850	GASK.945-1	1x ZV-FT	+ ZV-RT ...
851 - 1075	GASK.1100-1	1x ZV-FT	+ ZV-RT ...
1076 - 1325	GASK.1325-1	1x ZV-FT	+ ZV-RT ...
1326 - 1525	GASK.1550-1	1x ZV-FT	+ ZV-RT ...
1526 - 1775	GASK.1775-2	2x ZV-FT	+ ZV-RT ...
1776 - 2000	GASK.2000-2	2x ZV-FT	+ ZV-RT ...
2001 - 2225	GASK.2225-2*	2x ZV-FT	+ ZV-RT ...

max. 100 kg
max. 130 kg
max. 3 m²
max. 1725 mm
max. 2725 mm
≤ 2 : 1

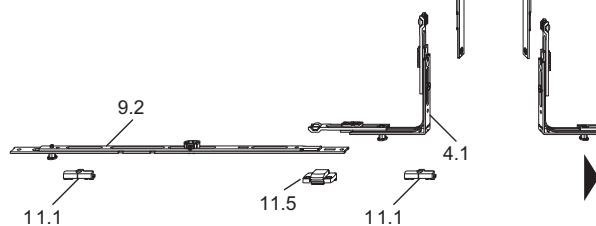
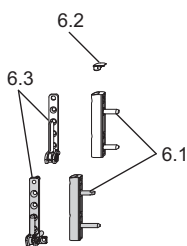

* See overview Min/max. dimensions
Please pay attention to the application diagrams!

Fitting for studio windows – constant handle position

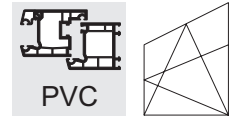

2

Basic equipment

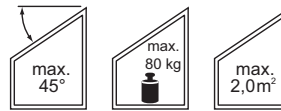
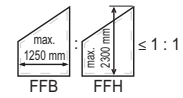
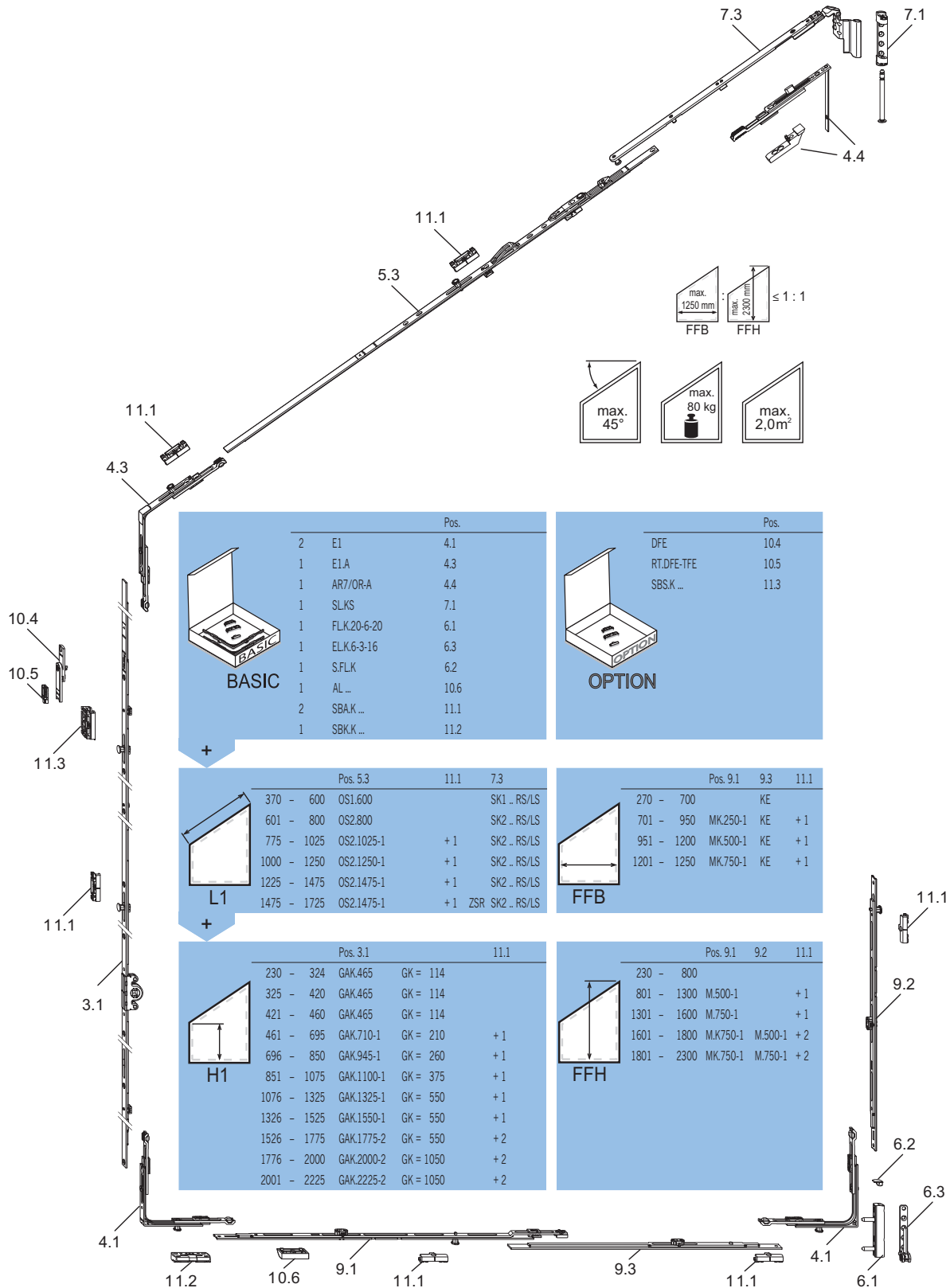

		Pos.
2	E1	4.1
1	E1A	4.3
1	AR7/OR-A	4.4
1	SLKS	7.1
1	FLK.20-6-20	6.1
1	ELK.6-3-16	6.3
1	S.FLK	6.2
1	AL ...	10.6
2	SBK.K...	11.1
1	SBK.K...	11.2

BASIC

	Pos.
DFE	10.4
RT.DFE-TFE	10.5
SBS.K...	11.3

OPTION

	Pos. 5.3	11.1	7.3
370 - 600	OS1.600		SK1 .. RS/LS
601 - 800	OS2.800		SK2 .. RS/LS
775 - 1025	OS2.1025-1	+1	SK2 .. RS/LS
1000 - 1250	OS2.1250-1	+1	SK2 .. RS/LS
1225 - 1475	OS2.1475-1	+1	SK2 .. RS/LS
1475 - 1725	OS2.1475-1	+1	ZSR SK2 .. RS/LS

L1

	Pos. 9.1	9.3	11.1
270 - 700		KE	
701 - 950	MK.250-1	KE	+1
951 - 1200	MK.500-1	KE	+1
1201 - 1250	MK.750-1	KE	+1

FFB

	Pos. 3.1	11.1
230 - 324	GAK.465	GK = 114
325 - 420	GAK.465	GK = 114
421 - 460	GAK.465	GK = 114
461 - 695	GAK.710-1	GK = 210 +1
696 - 850	GAK.945-1	GK = 260 +1
851 - 1075	GAK.1100-1	GK = 375 +1
1076 - 1325	GAK.1325-1	GK = 550 +1
1326 - 1525	GAK.1550-1	GK = 550 +1
1526 - 1775	GAK.1775-2	GK = 550 +2
1776 - 2000	GAK.2000-2	GK = 1050 +2
2001 - 2225	GAK.2225-2	GK = 1050 +2

H1

	Pos. 9.1	9.2	11.1
230 - 800			
801 - 1300	M.500-1		+1
1301 - 1600	M.750-1		+1
1601 - 1800	M.K.750-1	M.500-1	+2
1801 - 2300	MK.750-1	M.750-1	+2

FFH

Fitting for studio windows – central handle position

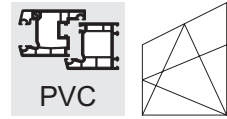

Basic equipment

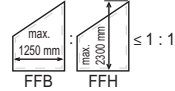
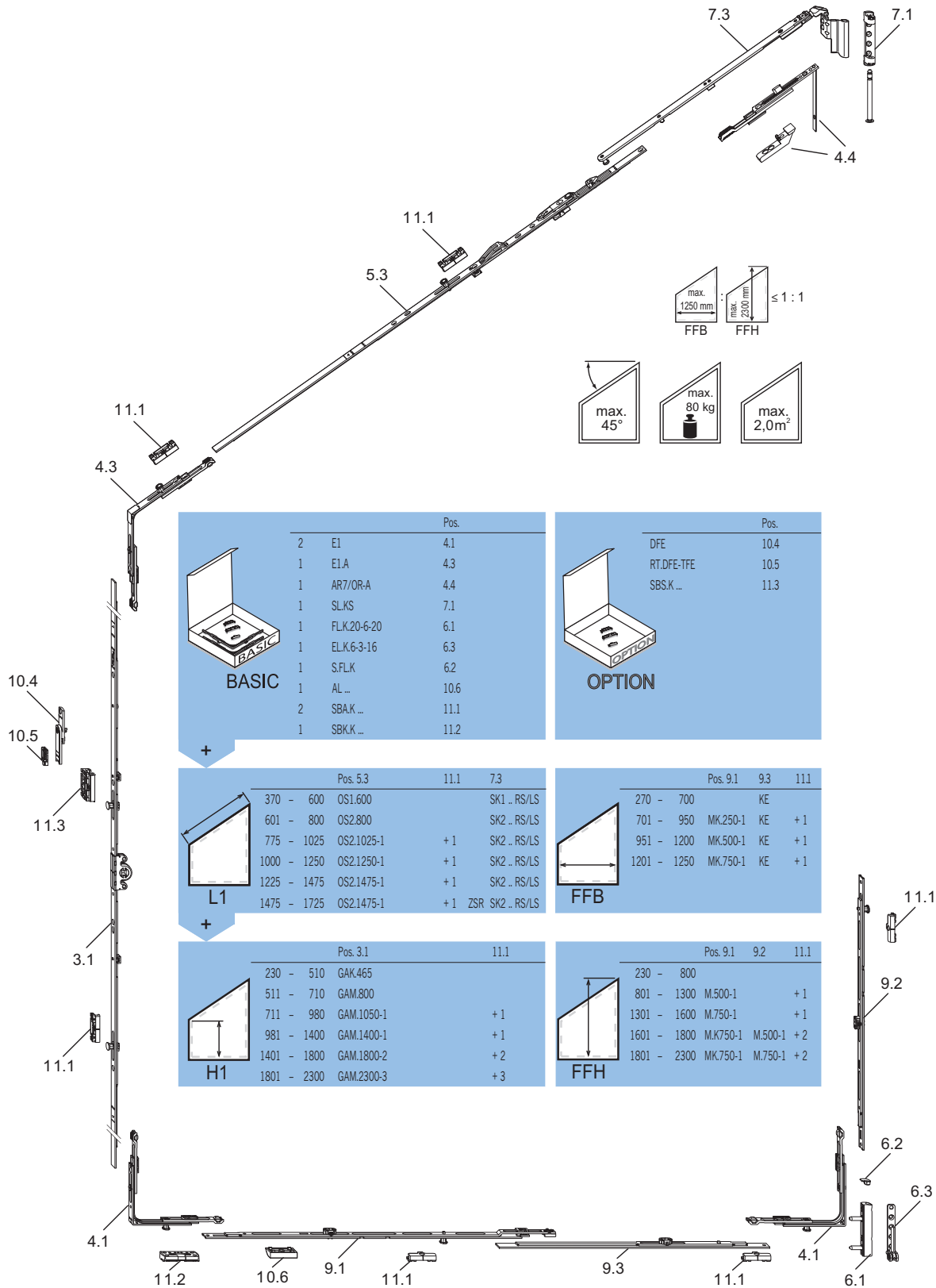

			Pos.
<p>BASIC</p>	2	E1	4.1
	1	E1.A	4.3
	1	AR7/OR-A	4.4
	1	SLKS	7.1
	1	FLK.20-6-20	6.1
	1	ELK.6-3-16	6.3
	1	S.FLK	6.2
	1	AL ...	10.6
	2	SBA.K ...	11.1
	1	SBK.K ...	11.2

			Pos.
<p>OPTION</p>	DFE	10.4	
	RT.DFE-TFE	10.5	
	SBS.K ...	11.3	

		Pos. 5.3	11.1	7.3
<p>L1</p>	370 - 600	OS1.600		SK1 ..RS/LS
	601 - 800	OS2.800		SK2 ..RS/LS
	775 - 1025	OS2.1025-1	+1	SK2 ..RS/LS
	1000 - 1250	OS2.1250-1	+1	SK2 ..RS/LS
	1225 - 1475	OS2.1475-1	+1	SK2 ..RS/LS
	1475 - 1725	OS2.1475-1	+1	ZSR SK2 ..RS/LS

		Pos. 9.1	9.3	11.1
<p>FFB</p>	270 - 700		KE	
	701 - 950	MK.250-1	KE	+1
	951 - 1200	MK.500-1	KE	+1
	1201 - 1250	MK.750-1	KE	+1

		Pos. 3.1	11.1
<p>H1</p>	230 - 510	GAK.465	
	511 - 710	GAM.800	
	711 - 980	GAM.1050-1	+1
	981 - 1400	GAM.1400-1	+1
	1401 - 1800	GAM.1800-2	+2
	1801 - 2300	GAM.2300-3	+3

		Pos. 9.1	9.2	11.1
<p>FFH</p>	230 - 800			
	801 - 1300	M.500-1		+1
	1301 - 1600	M.750-1		+1
	1601 - 1800	MK.750-1	M.500-1	+2
	1801 - 2300	MK.750-1	M.750-1	+2

Fitting for round arch windows – constant handle position

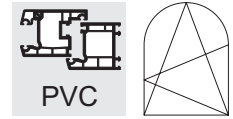

2

Basic equipment

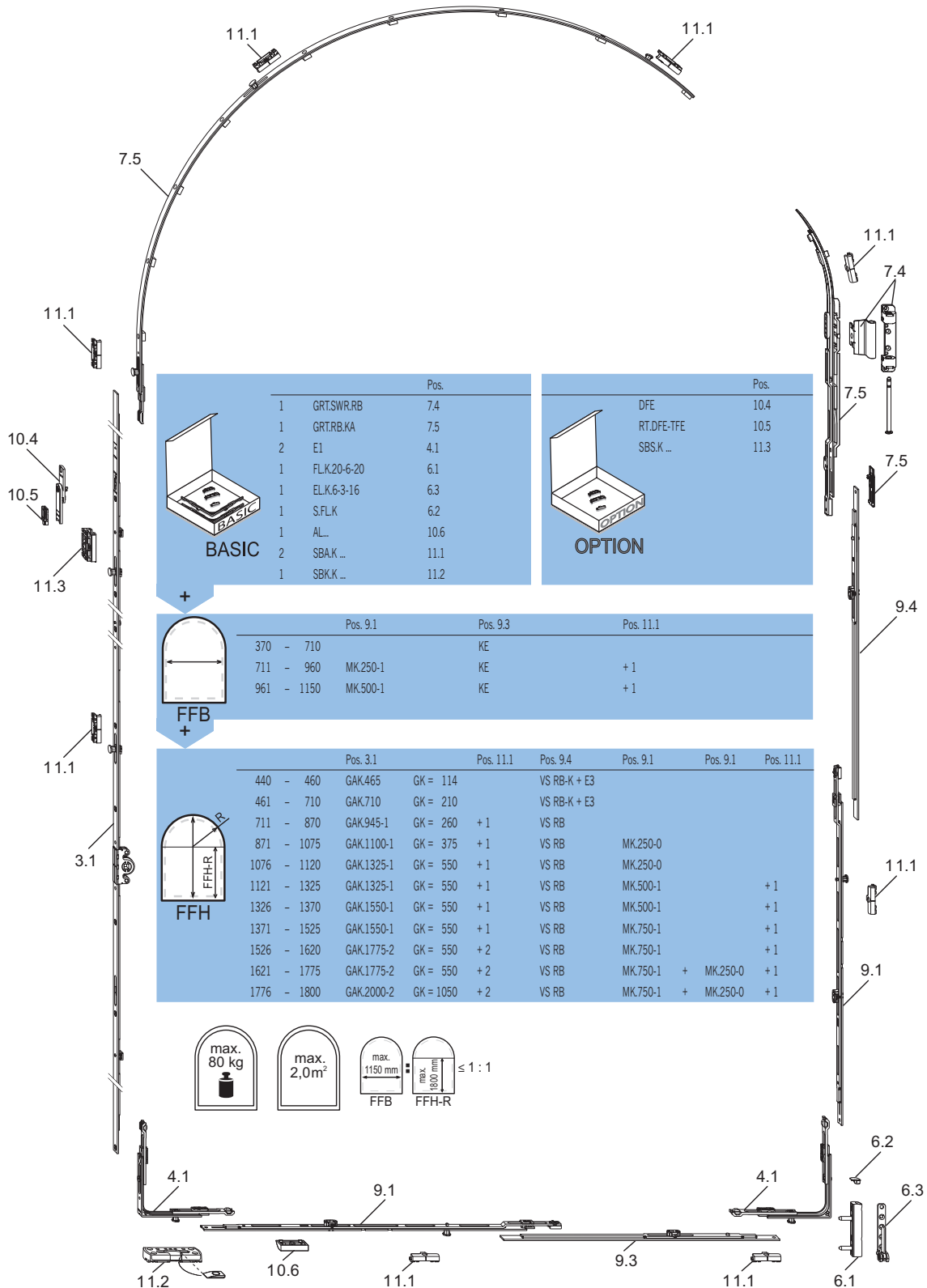

Fitting for round arch windows – central handle position

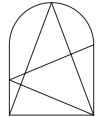
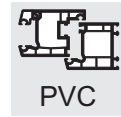

Basic equipment

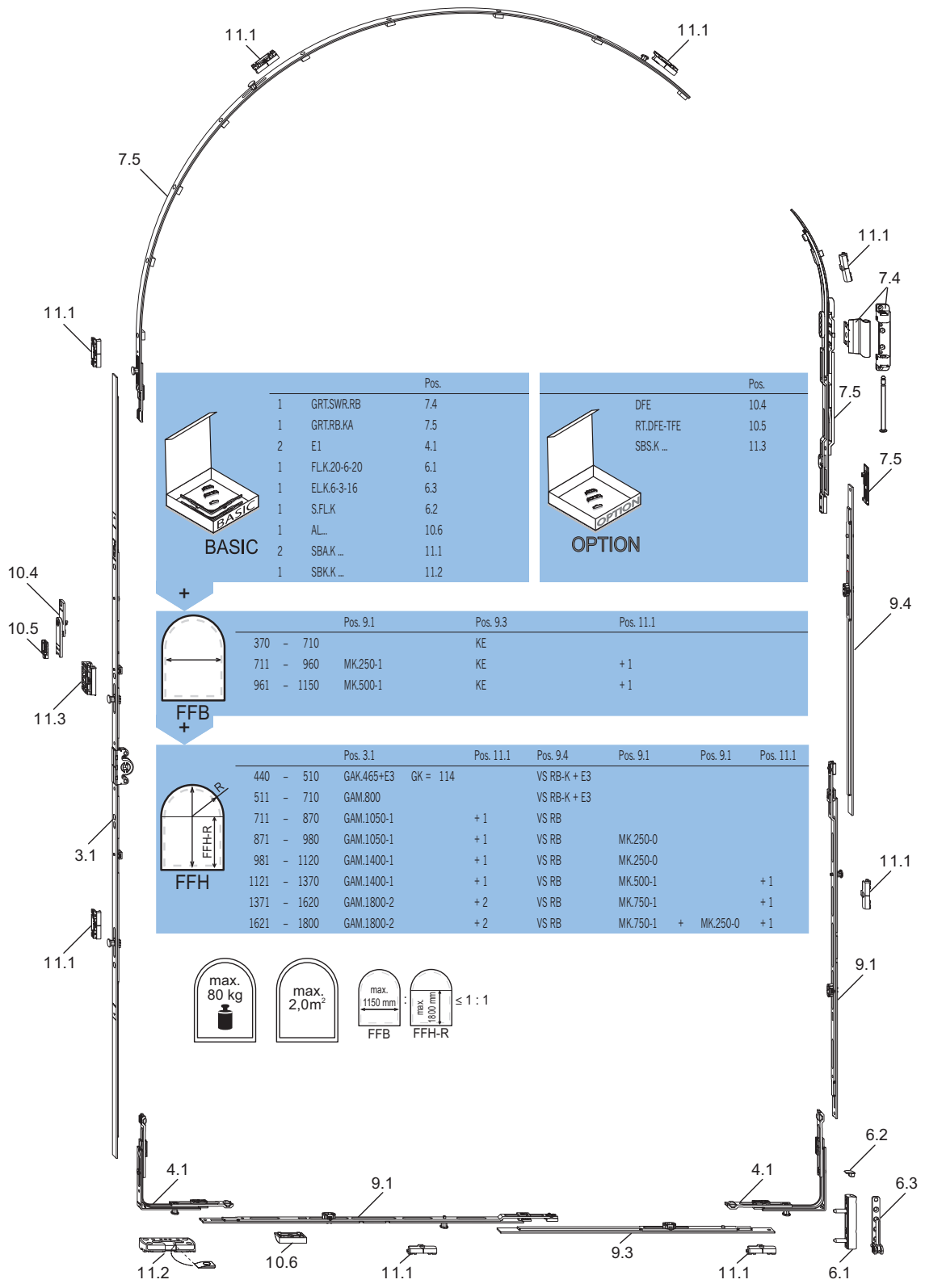

BASIC		Pos.
1	GRT.SWR.RB	7.4
1	GRT.RB.KA	7.5
2	E1	4.1
1	FL.K.20-6-20	6.1
1	EL.K.6-3-16	6.3
1	S.FL.K	6.2
1	AL...	10.6
2	SBA.K...	11.1
1	SBK.K...	11.2

OPTION		Pos.
	DFE	10.4
	RT.DFE-TFE	10.5
	SBS.K...	11.3

FFB	Pos. 9.1	Pos. 9.3	Pos. 11.1
370 - 710		KE	
711 - 960	MK.250-1	KE	+1
961 - 1150	MK.500-1	KE	+1

FFH	Pos. 3.1	GK = 114	Pos. 11.1	Pos. 9.4	Pos. 9.1	Pos. 9.1	Pos. 11.1
440 - 510	GAK.465+E3			VS RB-K + E3			
511 - 710	GAM.800			VS RB-K + E3			
711 - 870	GAM.1050-1		+1	VS RB			
871 - 980	GAM.1050-1		+1	VS RB		MK.250-0	
981 - 1120	GAM.1400-1		+1	VS RB		MK.250-0	
1121 - 1370	GAM.1400-1		+1	VS RB		MK.500-1	+1
1371 - 1620	GAM.1800-2		+2	VS RB		MK.750-1	+1
1621 - 1800	GAM.1800-2		+2	VS RB		MK.750-1 + MK.250-0	+1

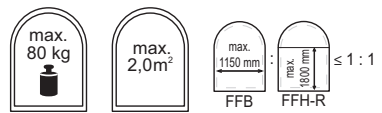

Turn-tilt fitting – constant handle position

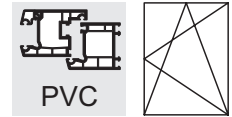

2

Basic equipment – Tilt before turn

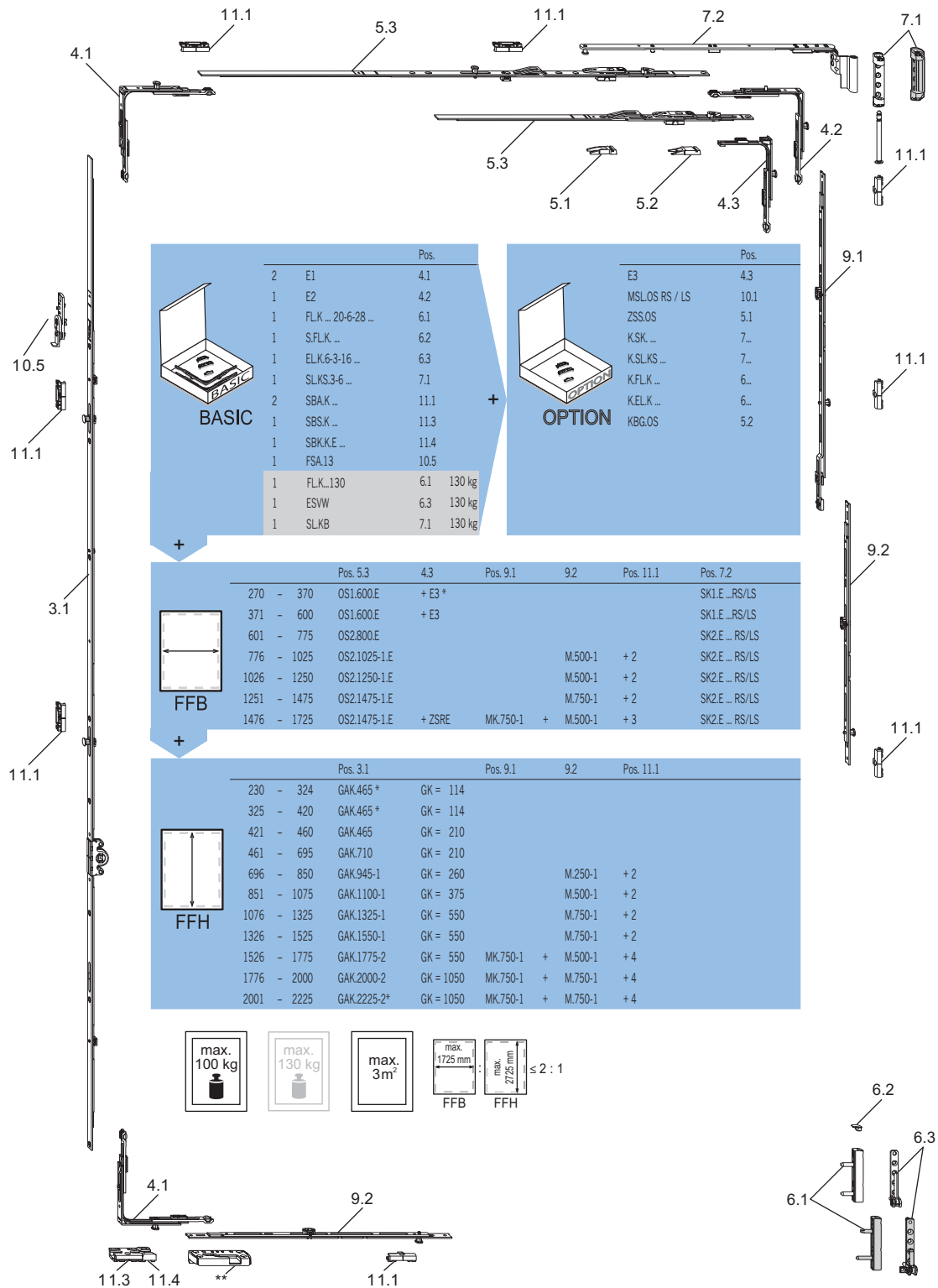

* See overview Min/max. dimensions

** Instead of the positions 11.3 and 11.4 it is possible to use the security keep SBS.K.PAD... (but not type SBS.K.PAB...!).

Please pay attention to the application diagrams!

Turn-tilt fitting - central handle position

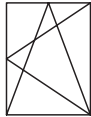
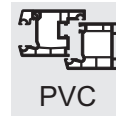

Basic equipment - Tilt before turn

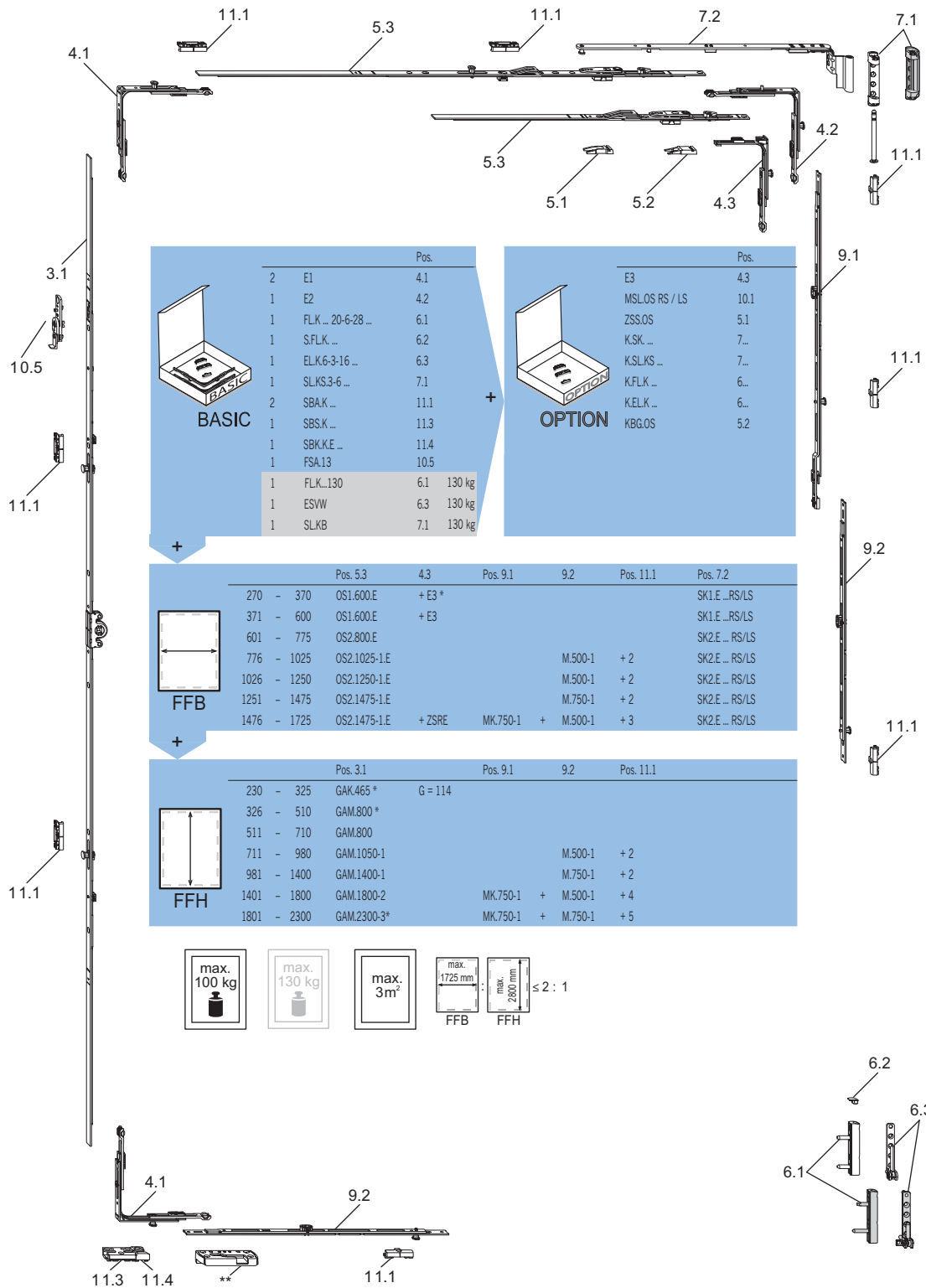

* See overview Min/max. dimensions

** Instead of the positions 11.3 and 11.4 it is possible to use the security keep SBS.K.PAD... (but not type SBS.K.PAB...!).

Please pay attention to the application diagrams!

Turn-only fittings - central handle position

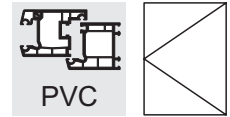

2

Basic equipment GAM

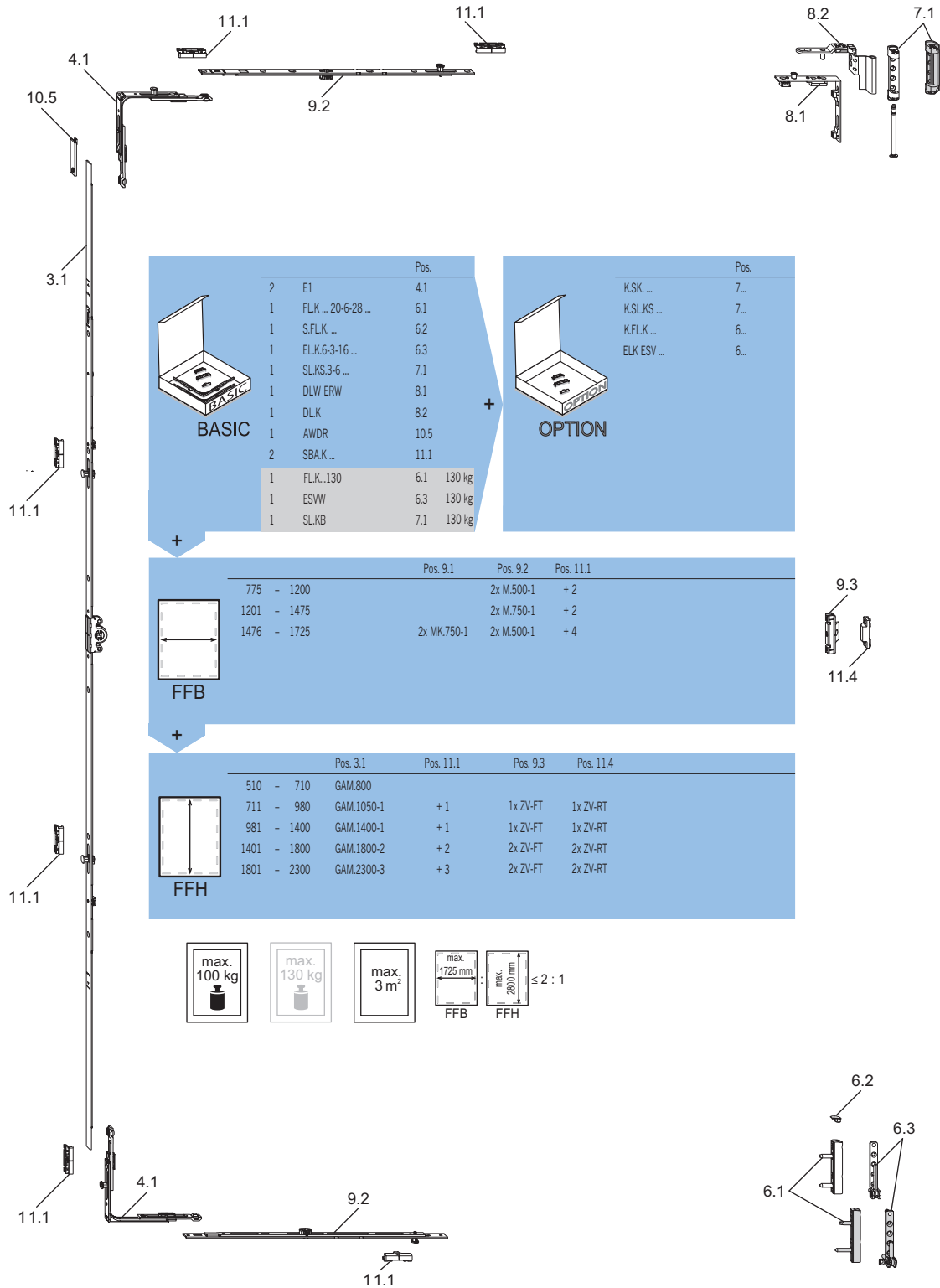

BASIC			OPTION		
		Pos.			Pos.
2	E1	4.1	KSK ...		7...
1	FLK... 20-6-28 ...	6.1	K.SLKS ...		7...
1	S.FLK ...	6.2	K.FLK ...		6...
1	ELK.6-3-16 ...	6.3	ELK ESV ...		6...
1	SLKS.3-6 ...	7.1			
1	DLW ERW	8.1			
1	DLK	8.2			
1	AWDR	10.5			
2	SBA.K...	11.1			
1	FLK...130	6.1	130 kg		
1	ESVW	6.3	130 kg		
1	SLKB	7.1	130 kg		

	Pos. 9.1	Pos. 9.2	Pos. 11.1
775 - 1200		2x M.500-1	+ 2
1201 - 1475		2x M.750-1	+ 2
1476 - 1725	2x MK.750-1	2x M.500-1	+ 4

	Pos. 3.1	Pos. 11.1	Pos. 9.3	Pos. 11.4
510 - 710	GAM.800			
711 - 980	GAM.1050-1	+ 1	1x ZV-FT	1x ZV-RT
981 - 1400	GAM.1400-1	+ 1	1x ZV-FT	1x ZV-RT
1401 - 1800	GAM.1800-2	+ 2	2x ZV-FT	2x ZV-RT
1801 - 2300	GAM.2300-3	+ 3	2x ZV-FT	2x ZV-RT

max. 100 kg
max. 130 kg
max. 3 m²
max. 1725 mm
max. 2810 mm
≤ 2 : 1

Turn-only fittings – central handle position

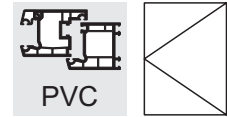

Basic equipment GAVM

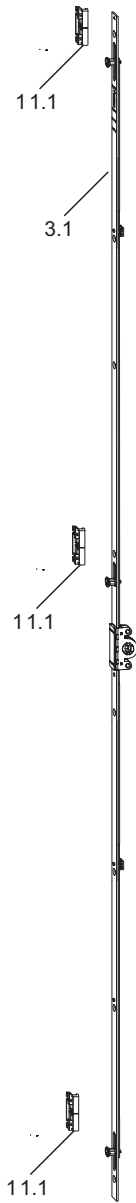
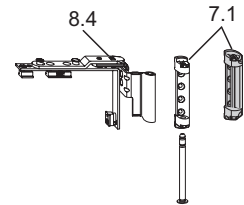

BASIC			OPTION		
		Pos.			Pos.
1	FLK ... 20-6-28 ...	6.1	K.SK ...		7...
1	S.FLK ...	6.2	K.SLKS ...		7...
1	EL.K.6-3-16 ...	6.3	K.FLK ...		6...
1	SL.KS.3-6 ...	7.1	ELK ESV ...		6...
1	DL.K.ET	8.4			
1	FLK...130	6.1 130 kg			
1	ESVW	6.3 130 kg			
1	SL.KB	7.1 130 kg			

FFB	

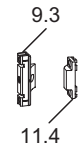

FFH		Pos. 3.1	Pos. 11.1	Pos. 9.3	Pos. 11.4
175	- 299	GAVM.175-1	+1		
300	- 419	GAVM.300-2	+2		
420	- 619	GAVM.420-2	+2		
620	- 919	GAVM.620-2	+2	1x ZV-FT	1x ZV-RT
920	- 1219	GAVM.920-2	+2	1x ZV-FT	1x ZV-RT
1220	- 1319	GAVM.1220-3	+3	1x ZV-FT	1x ZV-RT
1320	- 1519	GAVM.1320-3	+3	1x ZV-FT	1x ZV-RT
1520	- 1819	GAVM.1520-3	+3	2x ZV-FT	2x ZV-RT
1820	- 2019	GAVM.1820-4	+4	2x ZV-FT	2x ZV-RT
2020	- 2350	GAVM.2020-4	+4	2x ZV-FT	2x ZV-RT

$\leq 2 : 1$

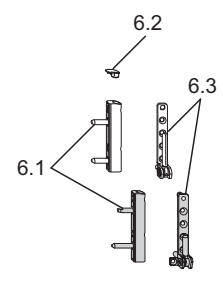

Turn-tilt fitting - constant handle position

Suitable for burglar-resistant windows RC2 / RC2 N with low threshold.

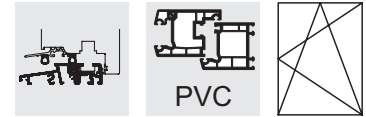

2

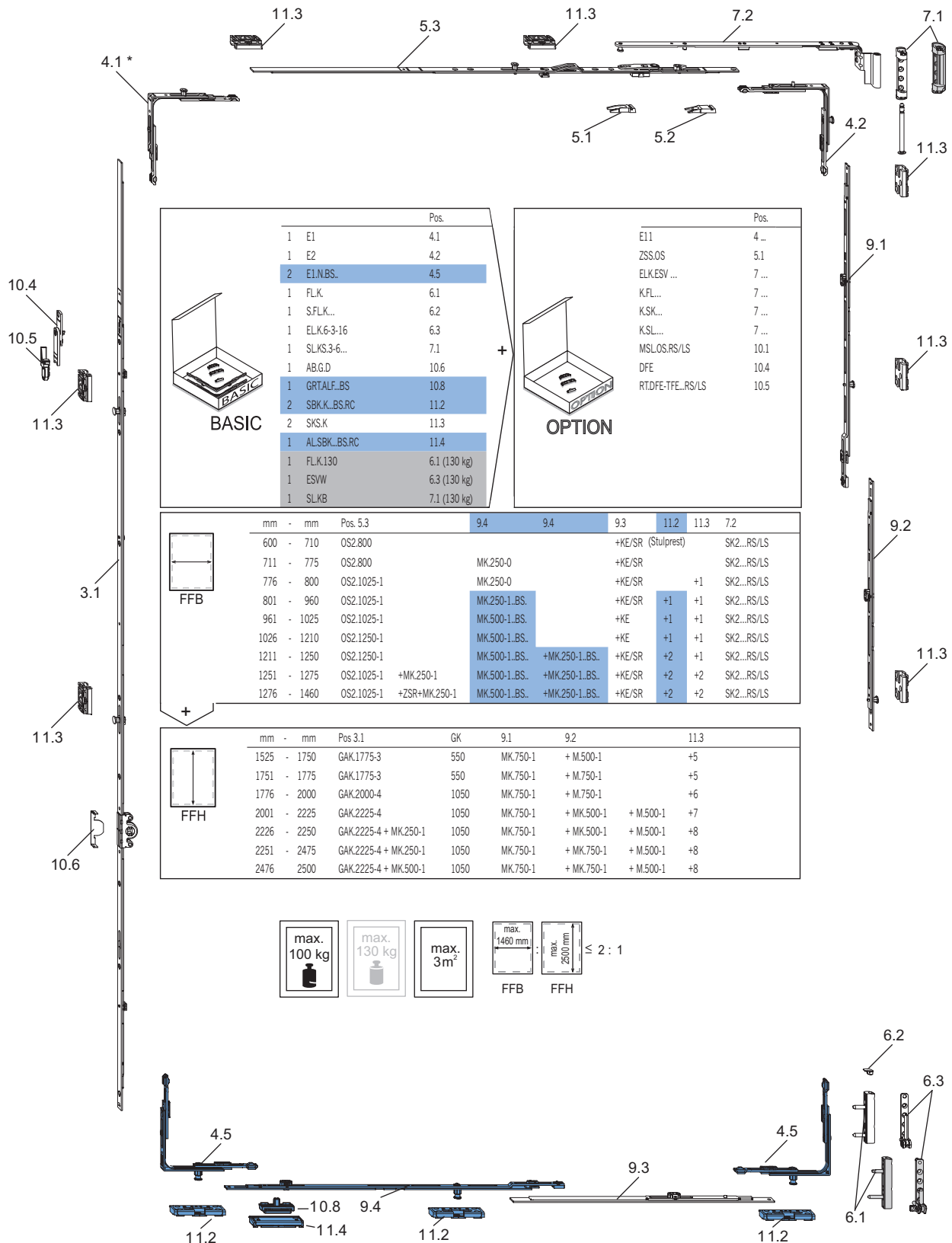

* For single and double-sash units with roller shutter boxes the component E11 must be used. The processing details RC2 can be gathered from the RC2 system tests. The RC2 fitting lists in this catalogue are only application examples. Please turn to your Winkhaus contact person.

Turn-tilt fitting - central handle position

Suitable for burglar-resistant windows RC2 / RC2 N with low threshold.

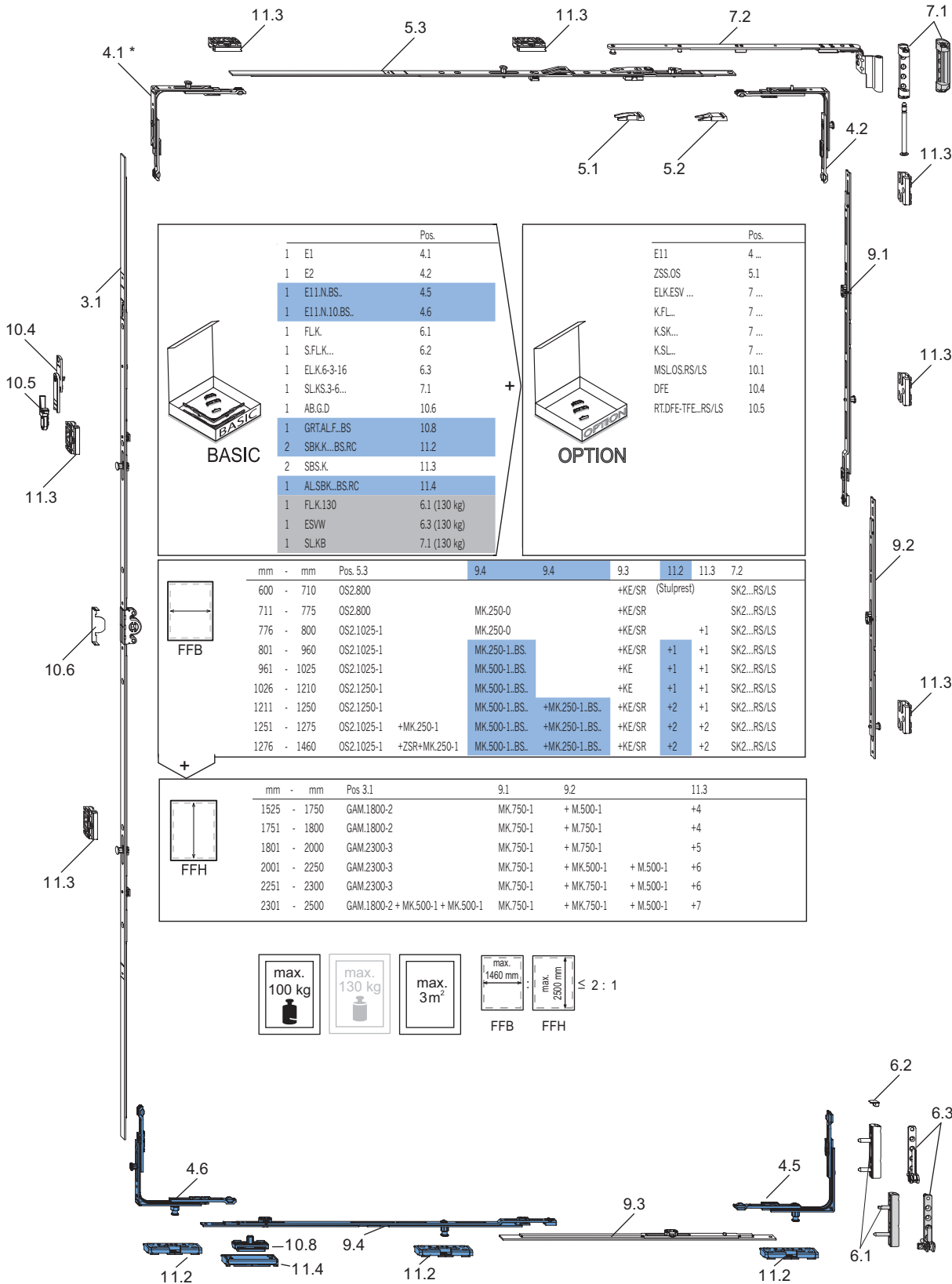
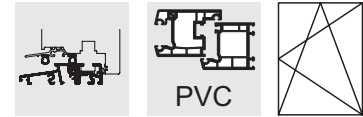

max.
100 kg

max.
130 kg

max.
3m³

max.
1460 mm

+

max.
2500 mm

≤ 2 : 1

FFB FFH

* For single and double-sash units with roller shutter boxes the component E11 must be used.
 The processing details RC2 can be gathered from the RC2 system tests. The RC2 fitting lists in this catalogue are only application examples. Please turn to your Winkhaus contact person.

Turn double sash fitting – constant handle position

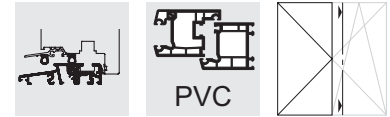

2

Suitable for burglar-resistant windows RC2 / RC2 N with low threshold.

		Pos.
1	E1	4.1
1	E2	4.2
2	E1.N.BS...	4.5
1	FLK	6.1
1	S.FLK...	6.2
1	ELK.6-3-16	6.3
1	SLKS.3-6...	7.1
1	AB.G.D	10.6
1	GRTALF_BS	10.8
2	SBK.K...BSRC	11.2
2	SBS.K	11.3
1	ALSBK_BS.RC	11.4
1	FLK.130	6.1 (130 kg)
1	ESVW	6.3 (130 kg)
1	SLKB	7.1 (130 kg)

		Pos.
E1.SBS.O		4 ...
E1.SBS.O.RC		4 ...
ZSS.OS		5.1
ELK.ESV ...		7 ...
K.SK...		7 ...
K.SL...		7 ...
K.FL...		7 ...
MSLOS.RS/LS		10.1
DFE		10.4
RT.DFE-TFES...RS/LS		10.5

mm	- mm	Pos. 5.3	9.4	9.4	9.3	11.2	11.3	7.2
600	- 710	OS2.800			+KE/SR (Stulprest)			SK2...RS/LS
711	- 775	OS2.800	MK250-0		+KE/SR			SK2...RS/LS
776	- 800	OS2.1025-1	MK250-0		+KE/SR		+1	SK2...RS/LS
801	- 960	OS2.1025-1	MK250-1.BS.		+KE/SR	+1	+1	SK2...RS/LS
961	- 1025	OS2.1025-1	MK500-1.BS.		+KE	+1	+1	SK2...RS/LS
1026	- 1210	OS2.1250-1	MK500-1.BS.		+KE	+1	+1	SK2...RS/LS
1211	- 1250	OS2.1250-1	MK500-1.BS.	+MK.250-1.BS.	+KE/SR	+2	+1	SK2...RS/LS
1251	- 1275	OS2.1025-1	MK500-1.BS.	+MK.250-1.BS.	+KE/SR	+2	+2	SK2...RS/LS
1276	- 1460	OS2.1025-1	MK500-1.BS.	+MK.250-1.BS.	+KE/SR	+2	+2	SK2...RS/LS

mm	- mm	Pos. 3.1	9.1	9.2	11.3	
1525	- 1750	GASK.1775-3	MK.750-1	+ M.500-1	+2	
1751	- 1775	GASK.1775-3	MK.750-1	+ M.750-1	+2	
1776	- 2000	GASK.2000-4	MK.750-1	+ M.750-1	+2	
2001	- 2225	GASK.2225-4	MK.750-1	+ MK.500-1	+ M.500-1	+3
2226	- 2250	GASK.2225-4 + MS.S0.250-1	MK.750-1	+ MK.500-1	+ M.500-1	+3
2251	- 2475	GASK.2225-4 + MS.S0.250-1	MK.750-1	+ MK.750-1	+ M.500-1	+3
2476	- 2500	GASK.2225-4 + MS.S0.500-1	MK.750-1	+ MK.750-1	+ M.500-1	+3

max.
100 kg

max.
130 kg

max.
3m²

max.
1460 mm

max.
250 mm

FFB FFH 1:2

For units with roller shutter boxes the component E1.SBS.O... must be used.

The processing details RC2 can be gathered from the RC2 system tests. The RC2 fitting lists in this catalogue are only application examples. Please turn to your Winkhaus contact person.

Turn double-sash fitting - central handle position

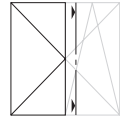
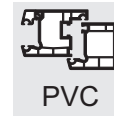
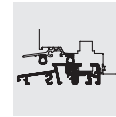

Suitable for burglar-resistant windows RC2 / RC2 N with low threshold.

		Pos.
1	E1	4.1
1	E2	4.2
1	E1.N.BS...	4.5
1	E1.N.SBS.U.BS	4.7
1	FLK	6.1
1	S.FLK...	6.2
1	ELK.6-3-16	6.3
1	SLKS.3-6...	7.1
1	AB.G.D	10.6
1	GRT.AL.F..BS	10.8
2	SBK.K..BS.RC	11.2
2	SBS.K	11.3
1	AL.SBK..BS.RC	11.4
1	FLK.130	7.1 (130 kg)
1	ESVW	6.3 (130 kg)
1	SLKB	7.1 (130 kg)

		Pos.
E1.SBS.O		4...
E1.SBS.O.RC		4...
ZSS.OS		5.1
ELK.ESV...		5.1
K.SK...		7...
K.SL...		7...
K.FL...		7...
MS.LOS.RS/LS		10.1
DFE		10.4
RT.DFE-TFES...RS/LS		10.5

mm	- mm	Pos. 5.3	9.4	9.4	9.3	11.2	11.3	7.2
600	- 710	OS2.800			+KE/SR (Stulprest)			SK2...RS/LS
711	- 775	OS2.800	MK.250-0		+KE/SR			SK2...RS/LS
776	- 800	OS2.1025-1	MK.250-0		+KE/SR		+1	SK2...RS/LS
801	- 960	OS2.1025-1	MK.250-1.BS.		+KE/SR	+1	+1	SK2...RS/LS
961	- 1025	OS2.1025-1	MK.500-1.BS.		+KE	+1	+1	SK2...RS/LS
1026	- 1210	OS2.1250-1	MK.500-1.BS.		+KE	+1	+1	SK2...RS/LS
1211	- 1250	OS2.1250-1	MK.500-1.BS.	+MK.250-1.BS.	+KE/SR	+2	+1	SK2...RS/LS
1251	- 1275	OS2.1025-1 +MK.250-1	MK.500-1.BS.	+MK.250-1.BS.	+KE/SR	+2	+2	SK2...RS/LS
1276	- 1460	OS2.1025-1 +ZSR+MK.250-1	MK.500-1.BS.	+MK.250-1.BS.	+KE/SR	+2	+2	SK2...RS/LS

mm	- mm	Pos. 3.1	9.1	9.2	11.3
1525	- 1750	GASM.1800-2	MK.750-1	+M.500-1	+2
1751	- 1800	GASM.1800-2	MK.750-1	+M.750-1	+2
1801	- 2000	GASM.2300-3	MK.750-1	+M.750-1	+2
2001	- 2250	GASM.2300-3	MK.750-1	+MK.500-1 +M.500-1	+3
2251	- 2300	GASM.2300-3	MK.750-1	+MK.750-1 +M.500-1	+3
2301	- 2500	GASM.1800-2 + MS.SU.500-1 + MS.SO.500-1	MK.750-1	+MK.750-1 +M.500-1	+3

max. 100 kg

max. 130 kg

max. 3m²

max. 1460 mm

max. 250 mm

FFB FFH ≤ 2 : 1

For units with roller shutter boxes the component E1.SBS.O... must be used.

The processing details RC2 can be gathered from the RC2 system tests. The RC2 fitting lists in this catalogue are only application examples. Please turn to your Winkhaus contact person.

Quick orientation

2

Our register system allows you to quickly allocate the listed component to the item in the fitting overview drawing. The item number specifies the chapter number in which the component can be found.

4.2
E2

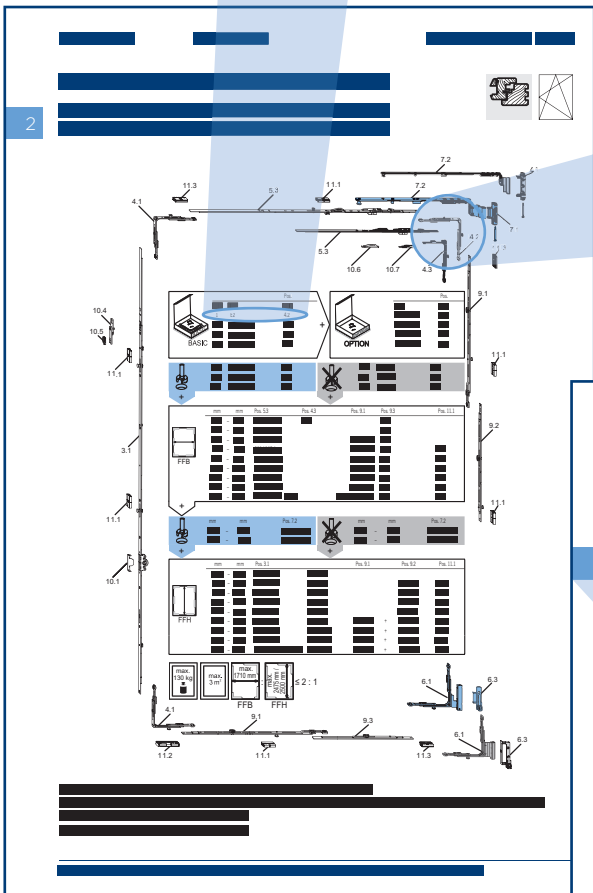

4.2

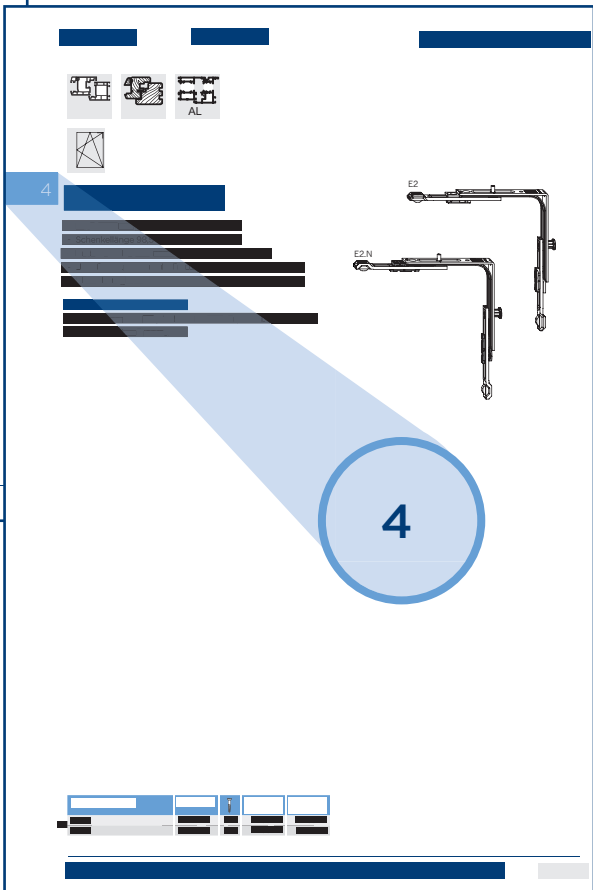

4

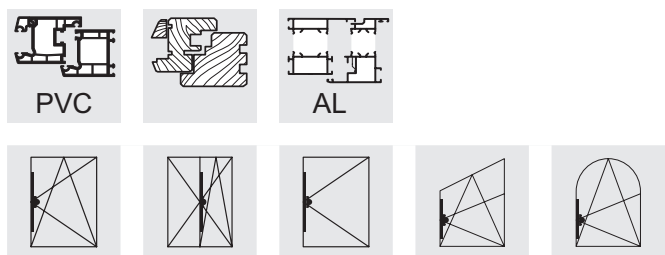

Drive rod GAK

- Constant handle position GK
- Backset 15.5 mm
- Clampable in fitting groove
- Functional parts such as DFE and TFE retrofittable (see table), does not apply to activPilot Comfort
- Handle position with reference to the sash rebate edge, in conformity with "dimension GK" (see table)
- For drilling and milling instructions see Group 15 installation drawings B-3-1
- Gear case for milling from rebate
- Gear case for mounting in drilled hole
- Fasten the window handle attachment with M5 x ..., DIN 965, 43 mm screw centres

Drive rod GAK ... BK

- With pre-assembled balcony door catch bolt
- Not suitable for activPilot Comfort / duoPort PAS

Drive rod GAK ... C

- incl. reinforced clamping mechanism within the profile groove

Item description	Item No.	Scope of application		Dimension GK	DFE	TFE	VPA1 Qty./Type	VPA2 Qty./Type	VPA3 Qty./Type
GAK.465	4926221	FFH 420 - 520	0	210			10 BD	100 KK	800 EK
GAK.465.C	4935841	FFH 420 - 520	0	210			10 BD	100 KK	800 EK
GAK.710	4926207	FFH 460 - 710	1	210			20 BD	600 EA	
GAK.710.C	4935843	FFH 460 - 710	1	210			20 BD	600 EA	
GAK.830	4926230	FFH 580 - 830	2	260			20 BD	600 EA	
GAK.830-1	4926231	FFH 580 - 830	2	260			20 BD	600 EA	
GAK.945	4926208	FFH 695 - 945	3	260	•	•	20 BD	400 EA	
GAK.945-1	4926209	FFH 695 - 945	3	260	•	•	20 BD	400 EA	
GAK.1100-1	4926234	FFH 850 - 1100	3	375	•	•	20 BD	360 EA	
GAK.1195-1	4926236	FFH 945 - 1195	4	470	•	•	20 BD	360 EA	
GAK.1195-2	4926237	FFH 945 - 1195	4	470	•	•	20 BD	360 EA	
GAK.1325-1	4978659	FFH 1075 - 1325	4	550	•	•	20 BD	360 EA	
GAK.1325-1.G500	4937485	FFH 1075 - 1325	5	500	•	•	20 BD	360 EA	
GAK.1325-2	4978670	FFH 1075 - 1325	4	550	•	•	20 BD	360 EA	
GAK.1550-1	4926224	FFH 1300 - 1550	5	550	•	•	10 BD	360 L1	
GAK.1550-2	4926225	FFH 1300 - 1550	5	550	•	•	10 BD	360 L1	
GAK.1775-2	4926228	FFH 1525 - 1775	7	550	•	•	10 BD	400 L1	
GAK.1775-3	4926229	FFH 1525 - 1775	7	550	•	•	10 BD	400 L1	
GAK.1850-2	5000529	FFH 1600 - 1850	7	715	•	•	10 BD	360 L1	
GAK.2000-2	4938089	FFH 1750 - 2000	8	1050	•	•	10 BD	360 L2	
GAK.2000-2.BK	4942670	FFH 1750 - 2000	8	1050	•	•	10 BD	360 L2	
GAK.2000-4	4938120	FFH 1750 - 2000	8	1050	•	•	10 BD	360 L2	
GAK.2225-2	4938122	FFH 1975 - 2225	9	1050	•	•	10 BD	360 L2	
GAK.2225-2.BK	4942672	FFH 1975 - 2225	9	1050	•	•	10 BD	360 L2	
GAK.2225-4	4938123	FFH 1975 - 2225	9	1050	•	•	10 BD	360 L2	
GAK.2225-4.BK	4942673	FFH 1975 - 2225	9	1050	•	•	10 BD	360 L2	
GAK.2450-4	5021551	FFH 2200 - 2450	10	1050	•	•	10 BD	360 L2	

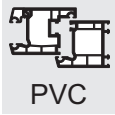

PVC



AL

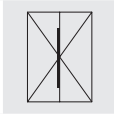
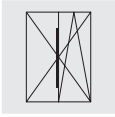
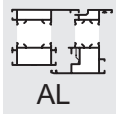

3

Drive rod GAK 0

- Constant handle position GK
- Backset 15.5 mm
- No locking point
- Suitable for double-sash windows with a second handle, fitting concealed behind a front profile
- Clampable in fitting groove
- Handle position with reference to the sash rebate edge, in conformity with "dimension GK" (see table)
- For drilling and milling instructions see Group 15 installation drawings B-3-1
- Gear case for milling from rebate
- Gear case for mounting in drilled hole
- Fasten the window handle attachment with M5 x ..., DIN 965, 43 mm screw centres



Item description	Item No.	Scope of application		Dimension GK	DFE	TFE	VPA1 Qty./Type	VPA2 Qty./Type	VPA3 Qty./Type
GAK.465	4926221	FFH 420 - 520	0	210			10 BD	100 KK	800 EK
GAK.710	4926207	FFH 460 - 710	1	210			20 BD	600 EA	
GAK.830	4926230	FFH 580 - 830	2	260			20 BD	600 EA	
GAK.945	4926208	FFH 695 - 945	3	260	•	•	20 BD	400 EA	
GAK.1100	4926233	FFH 850 - 1100	3	375	•	•	20 BD	360 EA	
GAK.1195	4926235	FFH 945 - 1195	4	470	•	•	20 BD	360 EA	
GAK.1325	4978658	FFH 1075 - 1325	4	550	•	•	20 BD	360 EA	
GAK.1550	4926223	FFH 1300 - 1550	5	550	•	•	10 BD	360 L1	
GAK.1775	4926227	FFH 1525 - 1775	7	550	•	•	10 BD	400 L1	
GAK.2000	4938088	FFH 1750 - 2000	8	1050	•	•	10 BD	360 L2	
GAK.2225	4938121	FFH 1975 - 2225	9	1050	•	•	10 BD	360 L2	

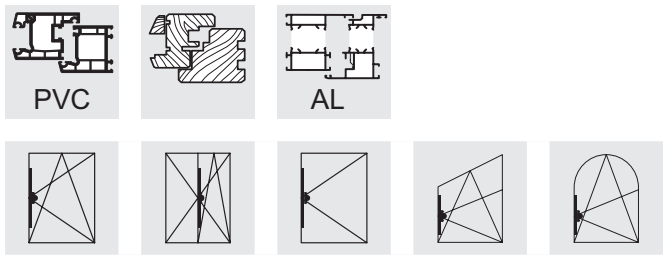



Drive rod GAK V < 700

- Constant handle position GK
- Backset 15.5 mm
- Locking gap less than 700 mm (V < 700)
- Clampable in fitting groove
- Functional parts such as DFE and TFE retrofittable (see table), does not apply to activPilot Comfort
- Handle position with reference to the sash rebate edge, in conformity with "dimension GK" (see table)
- For drilling and milling instructions see Group 15 installation drawings B-3-1
- Gear case for milling from rebate
- Gear case for mounting in drilled hole
- Fasten the window handle attachment with M5 x ..., DIN 965, 43 mm screw centres

Drive rod GAK ... BK

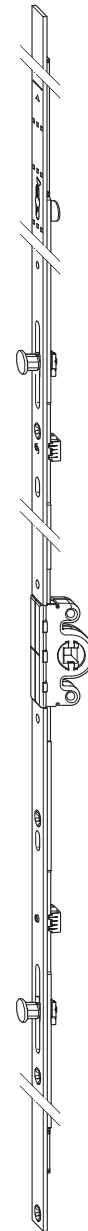
- With pre-assembled balcony door catch bolt
- Not suitable for activPilot Comfort / duoPort PAS



Item description	Item No.	Scope of application		Dimension GK	DFE	TFE	VPA1 Qty./Type	VPA2 Qty./Type
GAK.830-1	4926231	FFH 580 - 830	2	260			20 BD	600 EA
GAK.945-1	4926209	FFH 695 - 945	3	260	•	•	20 BD	400 EA
GAK.1100-1	4926234	FFH 850 - 1100	3	375	•	•	20 BD	360 EA
GAK.1195-2	4926237	FFH 945 - 1195	4	470	•	•	20 BD	360 EA
GAK.1325-2	4978670	FFH 1075 - 1325	4	550	•	•	20 BD	360 EA
GAK.1550-2	4926225	FFH 1300 - 1550	5	550	•	•	10 BD	360 L1
GAK.1775-3	4926229	FFH 1525 - 1775	7	550	•	•	10 BD	400 L1
GAK.2000-4	4938120	FFH 1750 - 2000	8	1050	•	•	10 BD	360 L2
GAK.2225-4	4938123	FFH 1975 - 2225	9	1050	•	•	10 BD	360 L2
GAK.2225-4.BK	4942673	FFH 1975 - 2225	9	1050	•	•	10 BD	360 L2
GAK.2450-4	5021551	FFH 2200 - 2450	10	1050	•	•	10 BD	360 L2

3

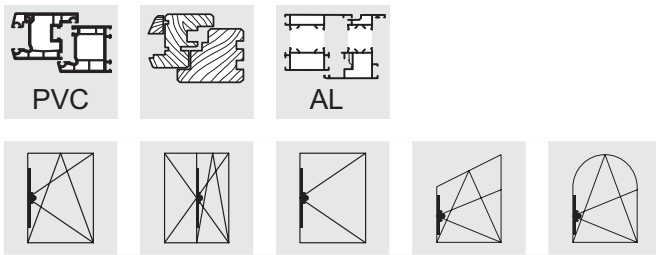

Drive rod GAK ... D 7,5

- Constant handle position GK
- Backset 7.5 mm
- Clampable in fitting groove
- Functional parts such as DFE and TFE retrofittable (see table), does not apply to activPilot Comfort
- Handle position with reference to the sash rebate edge, in conformity with "dimension GK" (see table)
- For drilling and milling instructions see Group 15 installation drawings B-3-2
- Gear case for milling from rebate
- Gear case for mounting in drilled hole
- Fasten the window handle attachment with M5 x ..., DIN 965, 43 mm screw centres



Item description	Item No.	Scope of application		Dimension GK	DFE	TFE	VPA1 Qty./Type	VPA2 Qty./Type	VPA3 Qty./Type
GAK.700.D7,5	4983049	FFH 530 - 700	2	260			20 BD	400 EA	
GAK.830-1.D7,5	4969431	FFH 580 - 830	2	260			20 BD	400 EA	
GAK.945-0.D7,5	5027123	FFH 695 - 945	3	0	•	•	20 BD	400 EA	
GAK.945-1.D7,5	4969430	FFH 695 - 945	3	260	•	•	20 BD	400 EA	
GAK.1100-1.D7,5	4969429	FFH 850 - 1100	3	375	•	•	20 BD	360 EA	
GAK.1195-1.D7,5	4969428	FFH 945 - 1195	4	470	•	•	20 BD	360 EA	
GAK.1195-2.D7,5	4980490	FFH 945 - 1195	4	470	•	•	20 BD	360 EA	
GAK.1325-1.D7,5	4969427	FFH 1075 - 1325	4	550	•	•	20 BD	360 EA	
GAK.1325-2.D7,5	4969426	FFH 1075 - 1325	4	550	•	•	20 BD	360 EA	
GAK.1550-1.D7,5	4969425	FFH 1300 - 1550	5	550	•	•	10 BD	400 L1	
GAK.1550-2.D7,5	4969424	FFH 1300 - 1550	5	550	•	•	10 BD	400 L1	
GAK.1775-2.D7,5	4969423	FFH 1525 - 1775	7	550	•	•	10 BD	400 L1	
GAK.1775-3.D7,5	4969422	FFH 1525 - 1775	7	550	•	•	10 BD	400 L1	
GAK.1850-2.D7,5	4969416	FFH 1600 - 1850	7	715	•	•	10 BD	360 L1	
GAK.2000-2.D7,5	4969415	FFH 1750 - 2000	8	1050	•	•	10 BD	360 L2	900 EU2
GAK.2000-4.D7,5	4969412	FFH 1750 - 2000	8	1050	•	•	10 BD	360 L2	
GAK.2225-2.D7,5	4969410	FFH 1975 - 2225	9	1050	•	•	10 BD	360 L2	900 EU2
GAK.2225-4.D7,5	4969407	FFH 1975 - 2225	9	1050	•	•	10 BD	360 L2	

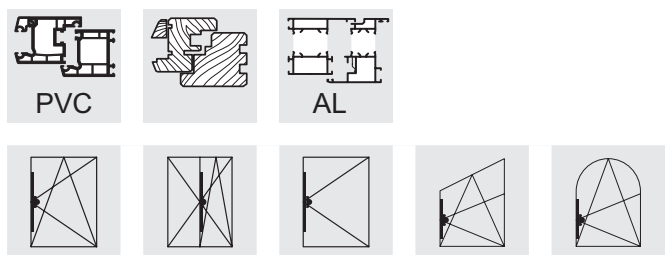

Drive rod GAK ... D 7,5 V < 700

- Constant handle position GK
- Locking gap less than 700 mm (V < 700)
- Backset 7.5 mm
- Clampable in fitting groove
- Functional parts such as DFE and TFE retrofittable (see table), does not apply to activPilot Comfort
- Handle position with reference to the sash rebate edge, in conformity with "dimension GK" (see table)
- For drilling and milling instructions see Group 15 installation drawings B-3-2
- Gear case for milling from rebate
- Gear case for mounting in drilled hole
- Fasten the window handle attachment with M5 x ..., DIN 965, 43 mm screw centres



Item description	Item No.	Scope of application		Dimension GK	DFE	TFE	VPA1 Qty./Type	VPA2 Qty./Type
GAK.830-1.D7,5	4969431	FFH 580 - 830	2	260			20 BD	400 EA
GAK.945-1.D7,5	4969430	FFH 695 - 945	3	260	•	•	20 BD	400 EA
GAK.1100-1.D7,5	4969429	FFH 850 - 1100	3	375	•	•	20 BD	360 EA
GAK.1195-2.D7,5	4980490	FFH 945 - 1195	4	470	•	•	20 BD	360 EA
GAK.1325-2.D7,5	4969426	FFH 1075 - 1325	4	550	•	•	20 BD	360 EA
GAK.1550-2.D7,5	4969424	FFH 1300 - 1550	5	550	•	•	10 BD	400 L1
GAK.1775-3.D7,5	4969422	FFH 1525 - 1775	7	550	•	•	10 BD	400 L1
GAK.2000-4.D7,5	4969412	FFH 1750 - 2000	8	1050	•	•	10 BD	360 L2
GAK.2225-4.D7,5	4969407	FFH 1975 - 2225	9	1050	•	•	10 BD	360 L2

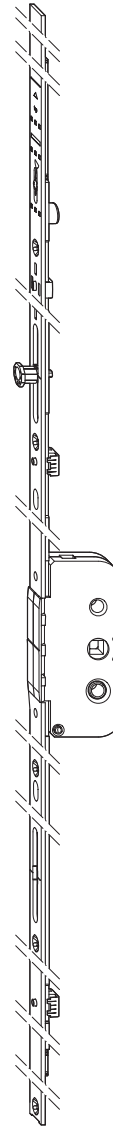
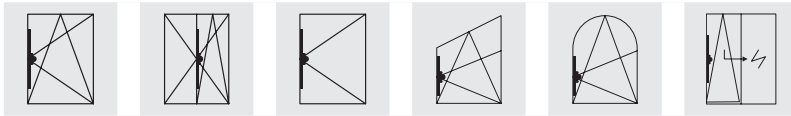

3

Drive rod GAK ... D 25 - 50

- Constant handle position GK
- The backset is optionally 25, 30, 35, 40, 45 or 50 mm
- Clampable in fitting groove
- Functional parts such as DFE and TFE retrofittable (see table), does not apply to activPilot Comfort
- Extensible with extension rods
- Handle position with reference to the sash rebate edge, in conformity with "dimension GK" (see table)
- For drilling and milling instructions see group 15, installation drawings B-3-4
- Gear case for milling from rebate
- Fasten the window handle attachment with M5 x ..., DIN 965, 43 mm screw centres

Item description	Item No.	Scope of application		Dimension GK	DFE	TFE	VPA1 Qty./Type	VPA2 Qty./Type	VPA3 Qty./Type
GAK.1325-1.D25	4978671	FFH 1075 - 1325	4	550	•	•	10 BD	200 EA	
GAK.1325-1.D30	4978672	FFH 1075 - 1325	4	550	•	•	10 BD	200 EA	
GAK.1325-1.D35	4978673	FFH 1075 - 1325	4	550	•	•	10 BD	200 EA	
GAK.1325-1.D40	4978674	FFH 1075 - 1325	4	550	•	•	10 BD	200 EA	
GAK.1325-1.D45	4978675	FFH 1075 - 1325	4	550	•	•	10 BD	200 EA	
GAK.1325-1.D50	4978676	FFH 1075 - 1325	4	550	•	•	10 BD	200 EA	
GAK.2000-4.D25	4938143	FFH 1750 - 2000	8	1050	•	•	10 BD	200 L2	
GAK.2000-4.D30	4938150	FFH 1750 - 2000	8	1050	•	•	10 BD	200 L2	
GAK.2000-4.D35	4938151	FFH 1750 - 2000	8	1050	•	•	10 BD	200 L2	
GAK.2000-4.D40	4938152	FFH 1750 - 2000	8	1050	•	•	10 BD	200 L2	
GAK.2000-4.D45	4938153	FFH 1750 - 2000	8	1050	•	•	10 BD	200 L2	
GAK.2000-4.D50	4938154	FFH 1750 - 2000	8	1050	•	•	10 BD	200 L2	
GAK.2225-4.D25	4938145	FFH 1975 - 2225	9	1050	•	•	10 BD	200 L2	
GAK.2225-4.D30	4938146	FFH 1975 - 2225	9	1050	•	•	10 BD	200 L2	
GAK.2225-4.D35	4938147	FFH 1975 - 2225	9	1050	•	•	10 BD	200 L2	900 EU2
GAK.2225-4.D40	4938148	FFH 1975 - 2225	9	1050	•	•	10 BD	200 L2	
GAK.2225-4.D45	4938149	FFH 1975 - 2225	9	1050	•	•	10 BD	200 L2	
GAK.2225-4.D50	4938160	FFH 1975 - 2225	9	1050	•	•	10 BD	200 L2	

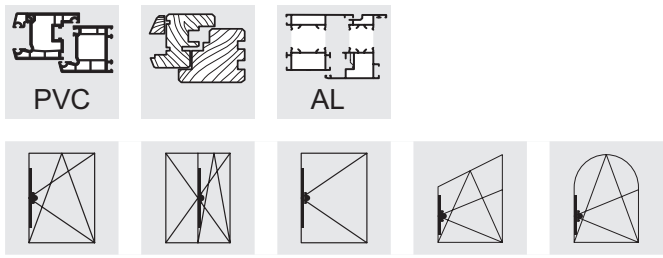

Drive rod GAKA

- Constant handle position GK
- The backset is optionally 25, 30, 35, 40, 45 or 50 mm
- Lockable, suitable for turn-tilt patio doors
- Clampable in fitting groove
- Extensible with extension rods
- Functional parts such as DFE and TFE retrofittable (see table)
- Handle position with reference to the sash rebate edge, in conformity with "dimension GK" (see table)
- For drilling and milling instructions see Group 15 installation drawings B-3-3
- Handle set see Group 10, accessories
- Gear case for milling from rebate

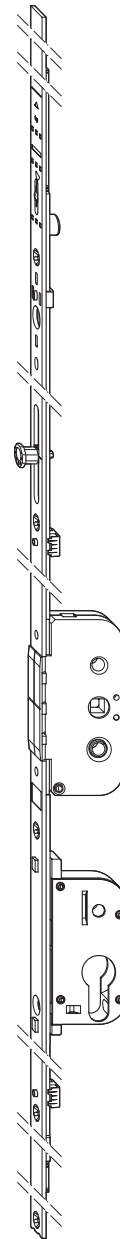

Item description	Item No.	Scope of application		Dimension GK	DFE	TFE	VPA1 Qty./Type	VPA2 Qty./Type	VPA3 Qty./Type
GAKA.1325-1.D25	4933449	FFH 1075 - 1325	4	550	•	•	10 BD	200 EA	
GAKA.1325-1.D30	4933473	FFH 1075 - 1325	4	550	•	•	10 BD	200 EA	
GAKA.1325-1.D35	4933474	FFH 1075 - 1325	4	550	•	•	10 BD	200 EA	
GAKA.1325-1.D40	4933475	FFH 1075 - 1325	4	550	•	•	10 BD	200 EA	
GAKA.1325-1.D45	4933479	FFH 1075 - 1325	4	550	•	•	10 BD	200 EA	
GAKA.2000-4.D25	4929007	FFH 1750 - 2000	8	1050	•	•	10 BD	200 L2	
GAKA.2000-4.D30	4929008	FFH 1750 - 2000	8	1050	•	•	10 BD	200 L2	900 EU2
GAKA.2000-4.D35	4929009	FFH 1750 - 2000	8	1050	•	•	10 BD	200 L2	
GAKA.2000-4.D40	4929010	FFH 1750 - 2000	8	1050	•	•	10 BD	200 L2	
GAKA.2000-2.D45	5015014	FFH 1750 - 2000	8	1050	•	•	10 BD	200 L2	
GAKA.2000-4.D45	4929011	FFH 1750 - 2000	8	1050	•	•	10 BD	200 L2	
GAKA.2000-2.D50	5015015	FFH 1750 - 2000	8	1050	•	•	10 BD	200 L2	
GAKA.2000-4.D50	4929012	FFH 1750 - 2000	8	1050	•	•	10 BD	200 L2	
GAKA.2225-4.D25	4929013	FFH 1775 - 2225	9	1050	•	•	10 BD	200 L2	
GAKA.2225-4.D30	4929014	FFH 1775 - 2225	9	1050	•	•	10 BD	200 L2	
GAKA.2225-4.D35	4929015	FFH 1775 - 2225	9	1050	•	•	10 BD	200 L2	
GAKA.2225-4.D40	4929016	FFH 1775 - 2225	9	1050	•	•	10 BD	200 L2	
GAKA.2225-2.D45	5015012	FFH 1775 - 2225	9	1050	•	•	10 BD	200 L2	
GAKA.2225-4.D45	4929017	FFH 1775 - 2225	9	1050	•	•	10 BD	200 L2	
GAKA.2225-2.D50	5015013	FFH 1775 - 2225	9	1050	•	•	10 BD	200 L2	
GAKA.2225-4.D50	4929018	FFH 1775 - 2225	9	1050	•	•	10 BD	200 L2	

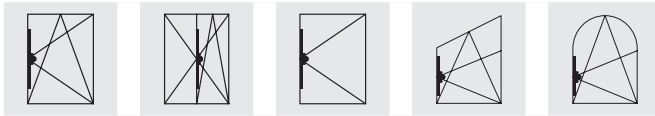

3

Drive rod GAK ... DFE

- Constant handle position GK
- Backset 15.5 mm
- With pre-assembled dual function element (limiter support and fail safe device)
- Clampable in fitting groove
- Handle position with reference to the sash rebate edge, in conformity with "dimension GK" (see table)
- For drilling and milling instructions see Group 15 installation drawings B-3-1
- Gear case for milling from rebate
- Gear case for mounting in drilled hole
- Fasten the window handle attachment with M5 x ..., DIN 965, 43 mm screw centres

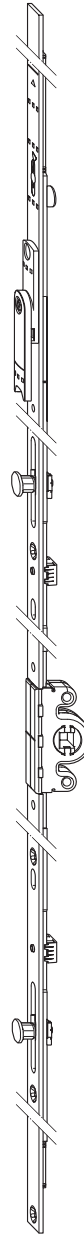

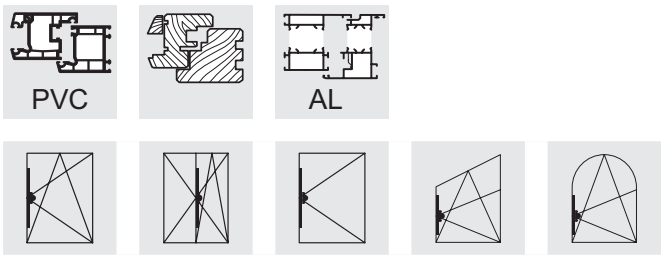

Item description	Item No.	Scope of application		Dimension GK	VPA1 Qty./Type	VPA2 Qty./Type
GAK.945-1.DFE	4927337	FFH 695 - 945	3	260	20 BD	400 EA
GAK.1100-1.DFE	4927338	FFH 850 - 1100	4	375	20 BD	360 EA
GAK.1195-1.DFE	4927339	FFH 945 - 1195	4	470	20 BD	360 EA
GAK.1195-2.DFE	4927340	FFH 945 - 1195	4	470	20 BD	360 EA
GAK.1325-1.DFE	4978677	FFH 1075 - 1325	4	550	20 BD	360 EA
GAK.1325-2.DFE	4978678	FFH 1075 - 1325	4	550	20 BD	360 EA
GAK.1550-1.DFE	4927343	FFH 1300 - 1550	6	550	10 BD	360 L1
GAK.1550-2.DFE	4927344	FFH 1300 - 1550	6	550	10 BD	360 L1
GAK.1775-2.DFE	4927345	FFH 1525 - 1775	8	550	10 BD	400 L1
GAK.1775-3.DFE	4927346	FFH 1525 - 1775	8	550	10 BD	400 L1
GAK.1850-2.DFE	5018304	FFH 1600 - 1850	7	715	10 BD	360 L1
GAK.2000-2.DFE	4938124	FFH 1750 - 2000	9	1050	10 BD	360 L2
GAK.2000-4.DFE	4938125	FFH 1750 - 2000	9	1050	10 BD	360 L2
GAK.2225-2.DFE	4938126	FFH 1975 - 2225	10	1050	10 BD	360 L2
GAK.2225-4.DFE	4938127	FFH 1975 - 2225	10	1050	10 BD	360 L2

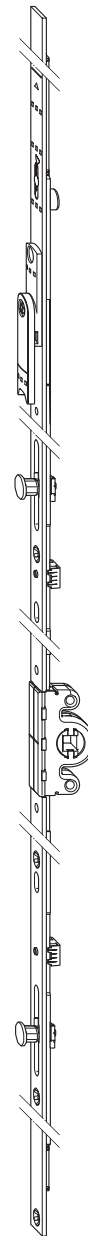

Drive rod GAK ... DFE V < 700

- Constant handle position GK
- Backset 15.5 mm
- Locking gap less than 700 mm (V < 700)
- With pre-assembled dual function element (limiter support and fail safe device)
- Clampable in fitting groove
- Handle position with reference to the sash rebate edge, in conformity with "dimension GK" (see table)
- For drilling and milling instructions see Group 15 installation drawings B-3-1
- Gear case for milling from rebate
- Gear case for mounting in drilled hole
- Fasten the window handle attachment with M5 x ..., DIN 965, 43 mm screw centres



Item description	Item No.	Scope of application		Dimension GK	VPA1 Qty./Type	VPA2 Qty./Type
GAK.945-1.DFE	4927337	FFH 695 - 945	3	260	20 BD	400 EA
GAK.1100-1.DFE	4927338	FFH 850 - 1100	4	375	20 BD	360 EA
GAK.1195-2.DFE	4927340	FFH 945 - 1195	4	470	20 BD	360 EA
GAK.1325-2.DFE	4978678	FFH 1075 - 1325	4	550	20 BD	360 EA
GAK.1550-2.DFE	4927344	FFH 1300 - 1550	6	550	10 BD	360 L1
GAK.1775-3.DFE	4927346	FFH 1525 - 1775	8	550	10 BD	400 L1
GAK.2000-4.DFE	4938125	FFH 1750 - 2000	9	1050	10 BD	360 L2
GAK.2225-4.DFE	4938127	FFH 1975 - 2225	10	1050	10 BD	360 L2

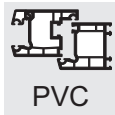

PVC



AL

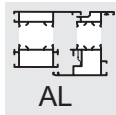

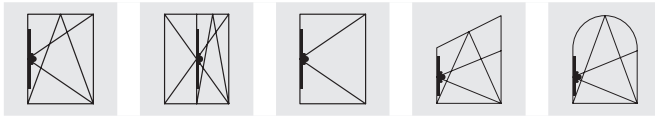

3

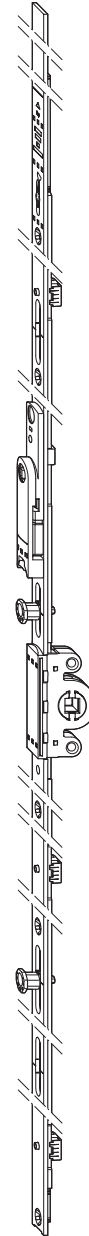

Drive rod GAK ... TFE

- Constant handle position GK
- Backset 15.5 mm
- With pre-assembled triple function element (limiter support, fail safe device and balcony door catch)
- Clampable in fitting groove
- Handle position with reference to the sash rebate edge, in conformity with "dimension GK" (see table)
- For drilling and milling instructions see Group 15 installation drawings B-3-1
- Gear case for milling from rebate
- Gear case for mounting in drilled hole
- Fasten the window handle attachment with M5 x ..., DIN 965, 43 mm screw centres
- Not suitable for activPilot Comfort / duoPort PAS



Item description	Item No.	Scope of application		Dimension GK	VPA1 Qty./Type	VPA2 Qty./Type
GAK.1325-1.TFE	4978679	FFH 1075 - 1325	4	550	20 BD	360 EA
GAK.2000-2.TFE	4938128	FFH 1750 - 2000	9	1050	10 BD	360 L2
GAK.2000-4.TFE	4938129	FFH 1750 - 2000	9	1050	10 BD	360 L2
GAK.2225-2.TFE	4938130	FFH 1975 - 2225	10	1050	10 BD	360 L2
GAK.2225-4.TFE	4938135	FFH 1975 - 2225	10	1050	10 BD	360 L2

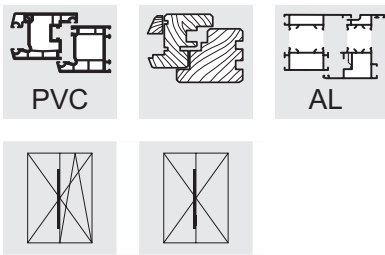

Double-sash drive rod GASK

- For constant handle position, in case of opposite fitting groove
- 1 piece
- Clampable in fitting groove
- Concealed lever, easily accessible
- 1-piece locking stroke similar to drive rod GAK or GAM
- Safety keeps are generally pre-assembled
- Adapter for functional elements DFE and TFE for mounting in security keeps - from GASK.945-1 and up



Item description	Item No.	Scope of application		VPA1 Qty./Type	VPA2 Qty./Type	VPA3 Qty./Type
GASK.710	4927021	FFH 550 - 710	2	10 BD	400 EA	
GASK.830-1	4927023	FFH 580 - 830	3	10 BD	400 EA	
GASK.945-1	4933702	FFH 695 - 945	3	10 BD	400 EA	
GASK.1100-1	4933703	FFH 850 - 1100	4	10 BD	400 EA	
GASK.1195-1	4998165	FFH 945 - 1195	4	10 BD	400 EA	
GASK.1325-1	4933705	FFH 1075 - 1325	5	10 BD	400 EA	
GASK.1325-2	4933706	FFH 1075 - 1325	5	10 BD	400 EA	
GASK.1550-1	4933707	FFH 1300 - 1550	6	10 BD	400 L1	900 EU2
GASK.1550-2	4933708	FFH 1300 - 1550	6	10 BD	400 L1	
GASK.1775-2	4933709	FFH 1525 - 1775	7	10 BD	400 L1	
GASK.1775-3	4933720	FFH 1525 - 1775	7	10 BD	400 L1	
GASK.2000-2	4933721	FFH 1750 - 2000	9	10 BD	400 L2	900 EU2
GASK.2000-4	4933722	FFH 1750 - 2000	9	10 BD	400 L2	
GASK.2225-2	4933723	FFH 1975 - 2225	9	10 BD	400 L2	900 EU2
GASK.2225-4	4933724	FFH 1975 - 2225	9	10 BD	400 L2	
GASK.2450-4	5068518	FFH 2200 - 2450	10	10 BD	400 L2	

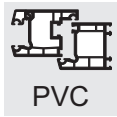

PVC



AL

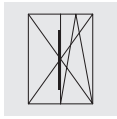

3

Double-sash drive rod GASK V < 700

- For constant handle position, in case of opposite fitting groove
- Locking gap less than 700 mm (V < 700)
- 1 piece
- Clampable in fitting groove
- Concealed lever, easily accessible
- 1-piece locking stroke similar to drive rod GAK or GAM
- Safety keeps are generally pre-assembled
- Adapter for functional elements DFE and TFE for mounting in security keeps - from GASK.945-1 and up



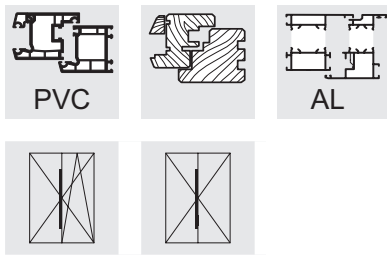

Item description	Item No.	Scope of application		VPA1 Qty./Type	VPA2 Qty./Type
GASK.830-1	4927023	FFH 580 - 830	3	10 BD	400 EA
GASK.945-1	4933702	FFH 695 - 945	3	10 BD	400 EA
GASK.1100-1	4933703	FFH 850 - 1100	4	10 BD	400 EA
GASK.1325-2	4933706	FFH 1075 - 1325	5	10 BD	400 EA
GASK.1550-2	4933708	FFH 1300 - 1550	6	10 BD	400 L1
GASK.1775-3	4933720	FFH 1525 - 1775	7	10 BD	400 L1
GASK.2000-4	4933722	FFH 1750 - 2000	9	10 BD	400 L2
GASK.2225-4	4933724	FFH 1975 - 2225	9	10 BD	400 L2

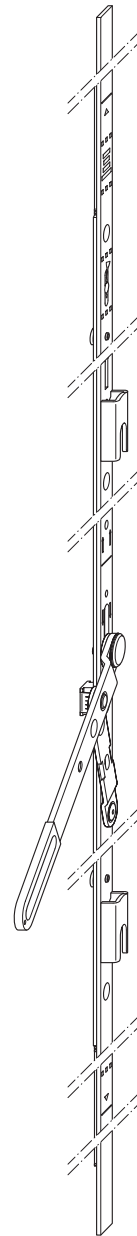

Double-sash drive rod GASK.GZ

- For constant handle position, in case of opposite fitting groove
- 1 piece
- 1-piece locking stroke similar to drive rod GAK or GAM
- Safety keeps are generally pre-assembled
- Adapter for functional elements DFE and TFE for mounting in security keeps (not possible for GASK.GZ.710 and GASK.GZ.830)
- Cutting is performed when open
- Functional elements DFE and TFE cannot be used in combination with GASK.GZ.710 and GASK.GZ.830!
- The models GASK.GZ.710, 830 and 945 always need to be fitted with E3 corner drive (bottom corner).
- Cannot be combined with backsets D7.5, D8.5 and D-6
- Not suitable for automatic screwing machines



Item description	Item No.	Scope of application		VPA1 Qty./Type	VPA2 Qty./Type
GASK.GZ.710.E3	4974967	FFH 460 - 710	2	10 BD	400 EA
GASK.GZ.830-1.E3	4974968	FFH 580 - 830	3	10 BD	400 EA
GASK.GZ.945-1.E3	4974969	FFH 695 - 945	4	10 BD	400 EA
GASK.GZ.1100-1	4965449	FFH 850 - 1100	4	10 BD	400 EA
GASK.GZ.1195-2	4965451	FFH 945 - 1195	4	10 BD	400 EA
GASK.GZ.1325-1	4965452	FFH 1075 - 1325	5	10 BD	400 EA
GASK.GZ.1325-2	4965453	FFH 1075 - 1325	5	10 BD	400 EA
GASK.GZ.1550-1	4965454	FFH 1300 - 1550	6	10 BD	400 L1
GASK.GZ.1550-2	4965455	FFH 1300 - 1550	6	10 BD	400 L1
GASK.GZ.1775-2	4965456	FFH 1525 - 1775	7	10 BD	400 L1
GASK.GZ.1775-3	4965457	FFH 1525 - 1775	7	10 BD	400 L1
GASK.GZ.2000-2	4965458	FFH 1750 - 2000	9	10 BD	400 L2
GASK.GZ.2000-4	4965459	FFH 1750 - 2000	9	10 BD	400 L2
GASK.GZ.2225-2	4965461	FFH 1975 - 2225	9	10 BD	400 L2
GASK.GZ.2225-4	4965462	FFH 1975 - 2225	9	10 BD	400 L2
GASK.GZ.2450-4	5021553	FFH 2200 - 2450	10	10 BD	400 L2

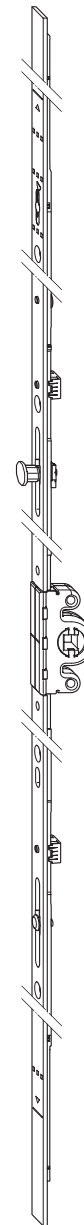
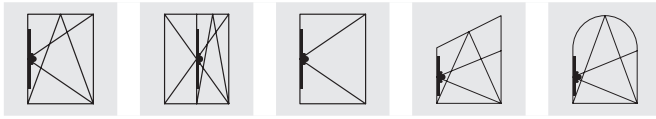

3

Drive rod GAM

- Central handle position
- Backset 15.5 mm
- Clampable in fitting groove
- Functional parts such as DFE and TFE retrofittable (see table), does not apply to activPilot Comfort
- For drilling and milling instructions see Group 15 installation drawings B-3-1
- Gear case for milling from rebate
- Gear case for mounting in drilled hole
- Fasten the window handle attachment with M5 x ..., DIN 965, 43 mm screw centres

Drive rod GAM ... BK

- With pre-assembled balcony door catch bolt
- Not suitable for activPilot Comfort / duoPort PAS

Item description	Item No.	Scope of application		DFE	TFE	VPA1 Qty./Type	VPA2 Qty./Type
GAM.800	4926267	FFH 510 - 800	2			20 BD	400 EA
GAM.1050	4926268	FFH 710 - 1050	2	•	•	20 BD	360 EA
GAM.1050-1	4926269	FFH 710 - 1050	2	•	•	20 BD	360 EA
GAM.1400	4926290	FFH 900 - 1400	4	•	•	20 BD	360 L1
GAM.1400-1	4926291	FFH 900 - 1400	4	•	•	20 BD	360 L1
GAM.1400-2	4926292	FFH 900 - 1400	4	•	•	20 BD	360 L1
GAM.1800	4926293	FFH 1300 - 1800	6	•	•	10 BD	360 L1
GAM.1800-2	4926295	FFH 1300 - 1800	6	•	•	10 BD	360 L1
GAM.2300	4938161	FFH 1800 - 2300	9	•	•	10 BD	360 L2
GAM.2300-3	4938163	FFH 1800 - 2300	9	•	•	10 BD	360 L2
GAM.2300-3.BK	4942674	FFH 1800 - 2300	9	•		10 BD	360 L2

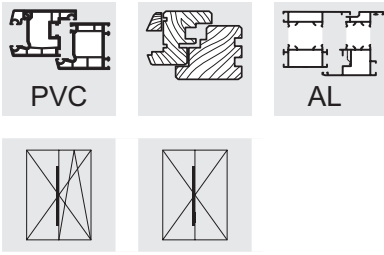

Drive rod GAM 0

- Central handle position
- Backset 15.5 mm
- No locking point
- Suitable for double-sash windows with a second handle, fitting concealed behind a front profile
- Clampable in fitting groove
- Functional parts such as DFE and TFE retrofittable (see table)
- For drilling and milling instructions see Group 15 installation drawings B-3-1
- Gear case for milling from rebate
- Gear case for mounting in drilled hole
- Fasten the window handle attachment with M5 x ..., DIN 965, 43 mm screw centres

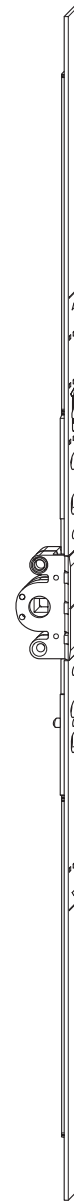

Item description	Item No.	Scope of application		DFE	TFE	VPA1 Qty./Type	VPA2 Qty./Type
GAM.800	4926267	FFH 510 - 800	2			20 BD	400 EA
GAM.1050	4926268	FFH 710 - 1050	2	•	•	20 BD	360 EA
GAM.1400	4926290	FFH 900 - 1400	4	•	•	20 BD	360 L1
GAM.1800	4926293	FFH 1300 - 1800	6	•	•	10 BD	360 L1
GAM.2300	4938161	FFH 1800 - 2300	9	•	•	10 BD	360 L2

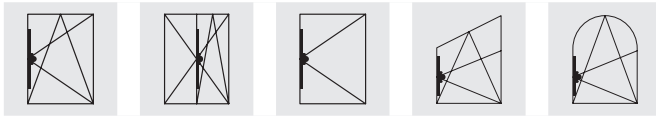

3

Drive rod GAM V < 700

- Central handle position
- Backset 15.5 mm
- Locking gap less than 700 mm (V < 700)
- Clampable in fitting groove
- Functional parts such as DFE and TFE retrofittable (see table), does not apply to activPilot Comfort
- For drilling and milling instructions see Group 15 installation drawings B-3-1
- Gear case for milling from rebate
- Gear case for mounting in drilled hole
- Fasten the window handle attachment with M5 x ..., DIN 965, 43 mm screw centres

Drive rod GAM ... BK

- With pre-assembled balcony door catch bolt
- Not suitable for activPilot Comfort / duoPort PAS

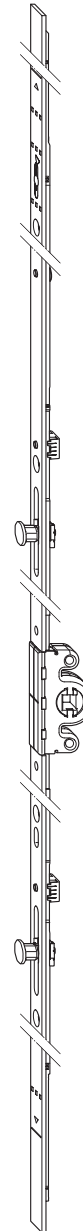

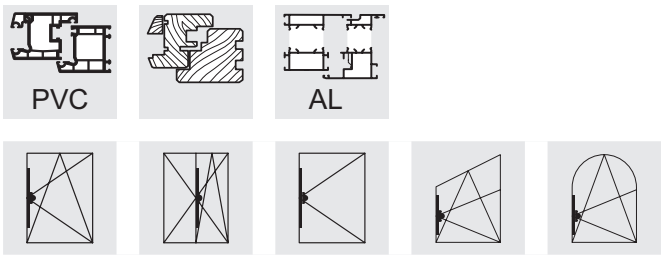

Item description	Item No.	Scope of application		DFE	TFE	VPA1 Qty./Type	VPA2 Qty./Type
GAM.1400-2	4926292	FFH 900 - 1400	4	•	•	20 BD	360 L1
GAM.1800-2	4926295	FFH 1300 - 1800	6	•	•	10 BD	360 L1
GAM.2300-3	4938163	FFH 1800 - 2300	9	•	•	10 BD	360 L2
GAM.2300-3.BK	4942674	FFH 1800 - 2300	9	•		10 BD	360 L2

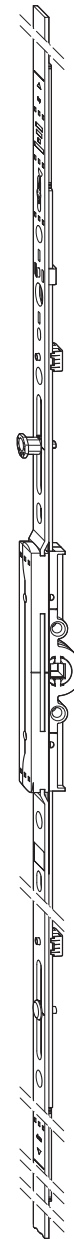

Drive rod GAM ... D 7,5

- Central handle position
- Backset 7.5 mm
- Clampable in fitting groove
- Functional parts such as DFE and TFE retrofittable (see table), does not apply to activPilot Comfort
- For drilling and milling instructions see Group 15 installation drawings B-3-2
- Gear case for milling from rebate
- Gear case for mounting in drilled hole
- Fasten the window handle attachment with M5 x ..., DIN 965, 43 mm screw centres



Item description	Item No.	Scope of application		DFE	TFE	VPA1 Qty./Type	VPA2 Qty./Type	VPA3 Qty./Type
GAM.800.D7,5	4969404	FFH 575 - 800	2			20 BD	400 EA	
GAM.1050-1.D7,5	4969403	FFH 710 - 1050	2	•	•	20 BD	360 EA	
GAM.1400-1.D7,5	4969402	FFH 900 - 1400	4	•	•	20 BD	360 L1	
GAM.1400-2.D7,5	4969401	FFH 900 - 1400	4	•	•	20 BD	360 L1	
GAM.1800-2.D7,5	4969400	FFH 1300 - 1800	6	•	•	10 BD	360 L1	
GAM.2300-3.D7,5	4969289	FFH 1800 - 2300	9	•	•	10 BD	360 L2	900 EU2

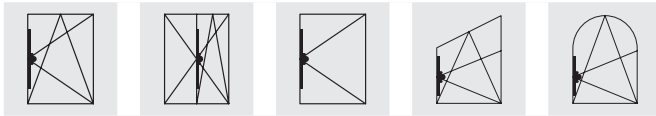

3

Drive rod GAM ... D 7,5 V < 700

- Central handle position
- Backset 7.5 mm
- Locking gap less than 700 mm (V < 700)
- Clampable in fitting groove
- Functional parts such as DFE and TFE retrofittable (see table), does not apply to activPilot Comfort
- For drilling and milling instructions see Group 15 installation drawings B-3-2
- Gear case for milling from rebate
- Gear case for mounting in drilled hole
- Fasten the window handle attachment with M5 x ..., DIN 965, 43 mm screw centres

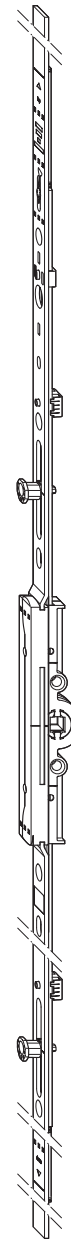

Item description	Item No.	Scope of application		DFE	TFE	VPA1 Qty./Type	VPA2 Qty./Type	VPA3 Qty./Type
GAM.1400-2.D7,5	4969401	FFH 900 - 1400	4	•	•	20 BD	360 L1	
GAM.1800-2.D7,5	4969400	FFH 1300 - 1800	6	•	•	10 BD	360 L1	
GAM.2300-3.D7,5	4969289	FFH 1800 - 2300	9	•	•	10 BD	360 L2	900 EU2

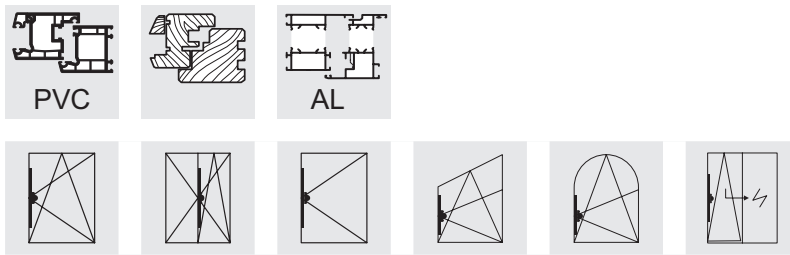

Drive rod GAM ... D 25 - 50

- Central handle position
- The backset is optionally 25, 30, 35, 40, 45 or 50 mm
- Clampable in fitting groove
- Functional parts such as DFE and TFE retrofittable (see table), does not apply to activPilot Comfort
- For drilling and milling instructions see group 15, installation drawings B-3-4
- Extensible with extension rods
- Gear case for milling from rebate

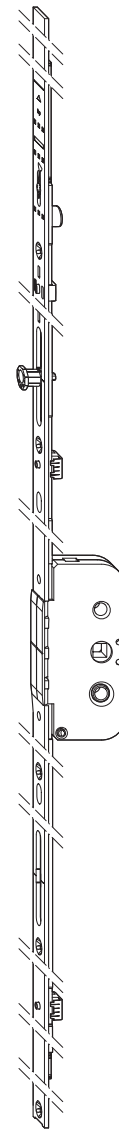

Item description	Item No.	Scope of application		DFE	TFE	VPA1 Qty./Type	VPA2 Qty./Type	VPA3 Qty./Type
GAM.800.D25	4941067	FFH 510 - 800	2			10 BD	200 EA	
GAM.800.D30	4941069	FFH 510 - 800	2			10 BD	200 EA	
GAM.1050-1.D25	4941081	FFH 710 - 1050	2	•	•	10 BD	200 EA	
GAM.1050-1.D30	4941082	FFH 710 - 1050	2	•	•	10 BD	200 EA	
GAM.1400-1.D25	4927159	FFH 900 - 1400	4	•	•	10 BD	200 L1	
GAM.1400-1.D30	4927171	FFH 900 - 1400	4	•	•	10 BD	200 L1	
GAM.1400-1.D35	4927172	FFH 900 - 1400	4	•	•	10 BD	200 L1	
GAM.1400-1.D40	4927173	FFH 900 - 1400	4	•	•	10 BD	200 L1	
GAM.1400-1.D45	4927174	FFH 900 - 1400	4	•	•	10 BD	200 L1	
GAM.1400-1.D50	4927175	FFH 900 - 1400	4	•	•	10 BD	200 L1	
GAM.1400-2.D25	4933312	FFH 900 - 1400	4	•	•	10 BD	200 L1	
GAM.1400-2.D30	4933313	FFH 900 - 1400	4	•	•	10 BD	200 L1	
GAM.1400-2.D35	4933315	FFH 900 - 1400	4	•	•	10 BD	200 L1	
GAM.1400-2.D40	4933316	FFH 900 - 1400	4	•	•	10 BD	200 L1	
GAM.1400-2.D45	4933317	FFH 900 - 1400	4	•	•	10 BD	200 L1	
GAM.1800-2.D25	4933319	FFH 1300 - 1800	6	•	•	10 BD	200 L1	
GAM.1800-2.D30	4933340	FFH 1300 - 1800	6	•	•	10 BD	200 L1	
GAM.1800-2.D35	4933341	FFH 1300 - 1800	6	•	•	10 BD	200 L1	
GAM.1800-2.D40	4933342	FFH 1300 - 1800	6	•	•	10 BD	200 L1	
GAM.1800-2.D45	4933343	FFH 1300 - 1800	6	•	•	10 BD	200 L1	
GAM.2300-3.D25	4938167	FFH 1800 - 2300	9	•	•	10 BD	200 L2	900 EU2
GAM.2300-3.D30	4938168	FFH 1800 - 2300	9	•	•	10 BD	200 L2	
GAM.2300-3.D35	4938169	FFH 1800 - 2300	9	•	•	10 BD	200 L2	
GAM.2300-2.D40	4936028	FFH 1800 - 2300	9	•	•	10 BD	200 L2	
GAM.2300-3.D40	4938170	FFH 1800 - 2300	9	•	•	10 BD	200 L2	
GAM.2300-3.D45	4938427	FFH 1800 - 2300	9	•	•	10 BD	200 L2	
GAM.2300-3.D50	4938428	FFH 1800 - 2300	9	•	•	10 BD	200 L2	900 EU2

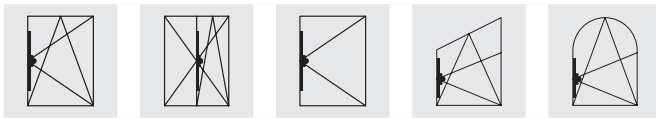
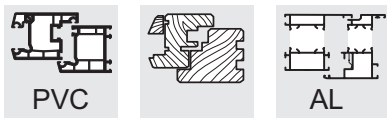

3

Drive rod GAMA

- Central handle position
- The backset is optionally 25, 30, 35, 40, 45 or 50 mm
- Lockable, suitable for turn-tilt patio doors
- Extensible with extension rods
- Clampable in fitting groove
- Handle set see Group 10, accessories
- Functional parts such as DFE and TFE retrofittable (see table)
- For drilling and milling instructions see Group 15 installation drawings B-3-3
- Gear case for milling from rebate

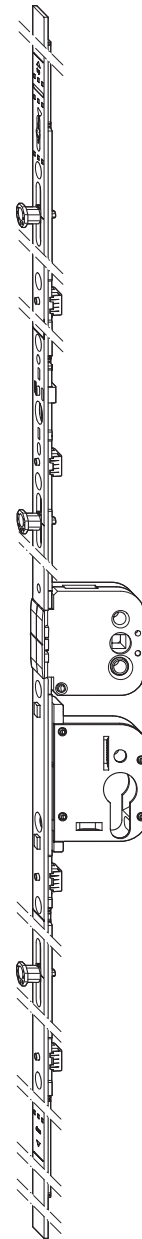

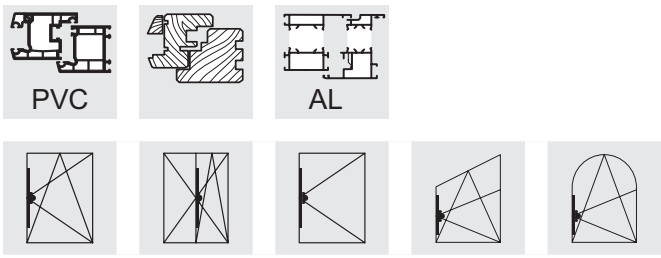

Item description	Item No.	Scope of application		DFE	TFE	VPA1 Qty./Type	VPA2 Qty./Type	VPA3 Qty./Type
GAMA.2300-3.D25	4927099	FFH 1800 - 2300	8	•	•	10 BD	200 L2	900 EU2
GAMA.2300-3.D30	4927160	FFH 1800 - 2300	8	•	•	10 BD	200 L2	
GAMA.2300-3.D35	4927161	FFH 1800 - 2300	8	•	•	10 BD	200 L2	
GAMA.2300-3.D40	4927162	FFH 1800 - 2300	8	•	•	10 BD	200 L2	
GAMA.2300-3.D45	4927164	FFH 1800 - 2300	8	•	•	10 BD	200 L2	
GAMA.2300-3.D50	4927166	FFH 1800 - 2300	8	•	•	10 BD	200 L2	

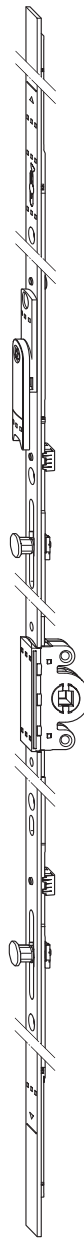

Drive rod GAM ... DFE

- Central handle position
- Backset 15.5 mm
- With pre-assembled dual function element (limiter support and fail safe device)
- Clampable in fitting groove
- For drilling and milling instructions see Group 15 installation drawings B-3-1
- Gear case for milling from rebate
- Gear case for mounting in drilled hole
- Fasten the window handle attachment with M5 x ..., DIN 965, 43 mm screw centres
- Not suitable for activPilot Comfort / duoPort PAS



Item description	Item No.	Scope of application		VPA1 Qty./Type	VPA2 Qty./Type
GAM.1050-1.DFE	4927354	FFH 710 - 1050	2	20 BD	360 EA
GAM.1400-1.DFE	4927355	FFH 900 - 1400	4	20 BD	360 L1
GAM.1400-2.DFE	4927356	FFH 900 - 1400	4	20 BD	360 L1
GAM.1800-2.DFE	4927357	FFH 1300 - 1800	7	10 BD	360 L1
GAM.2300-3.DFE	4938164	FFH 1800 - 2300	9	10 BD	360 L2

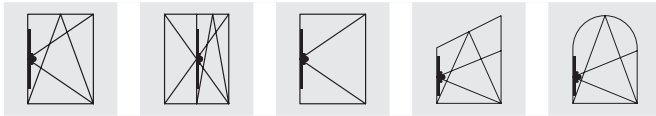

3

Drive rod GAM ... TFE

- Central handle position
- Backset 15.5 mm
- With pre-assembled triple function element (limiter support, fail safe device and balcony door catch)
- Clampable in fitting groove
- For drilling and milling instructions see Group 15 installation drawings B-3-1
- Gear case for milling from rebate
- Gear case for mounting in drilled hole
- Fasten the window handle attachment with M5 x ..., DIN 965, 43 mm screw centres
- Not suitable for activPilot Comfort / duoPort PAS



Item description	Item No.	Scope of application		VPA1 Qty./Type	VPA2 Qty./Type
GAM.1800-2.TFE	4927363	FFH 1300 - 1800	7	10 BD	360 L1
GAM.2300-3.TFE	4938165	FFH 1800 - 2300	9	10 BD	360 L2

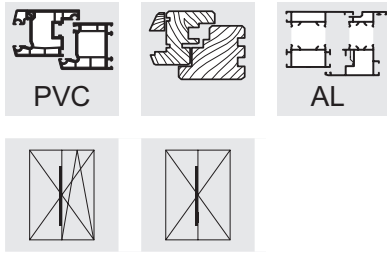



Double-sash drive rod GASM

- Central handle position with opposing eurogroove
- 1 piece
- GASM.1050 is always used in combination with corner drive E3.
- Clampable in fitting groove
- Concealed lever, easily accessible
- 1-piece locking stroke similar to drive rod GAK or GAM
- Safety keeps are generally pre-assembled
- Adapters for functional parts DFE and TFE can be fitted to security keeps – from GASM.1050-1 onwards (not applicable to activPilot Comfort!)

Double-sash drive rod GASM ... L

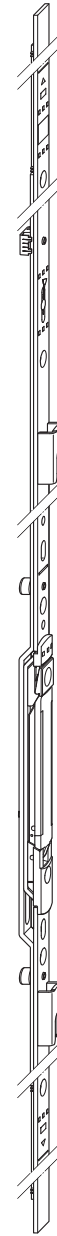
- As described above, but with long lever



Item description	Item No.	Scope of application		VPA1 Qty./Type	VPA2 Qty./Type	VPA3 Qty./Type
GASM.800	4927112	FFH 560 - 800	3	10 BD	400 EA	
GASM.1050-1.E3	4933666	FFH 710 - 1050	4	10 BD	400 EA	
GASM.1400-1	4933667	FFH 900 - 1400	5	10 BD	400 L1	
GASM.1400-2	4933668	FFH 900 - 1400	5	10 BD	400 L1	
GASM.1400-2.L	4936721	FFH 900 - 1400	5	10 BD	400 L1	
GASM.1800-2	4933700	FFH 1300 - 1800	7	10 BD	400 L1	
GASM.2300-3	4933701	FFH 1800 - 2300	9	10 BD	400 L2	900 EU2

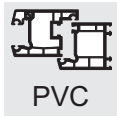

PVC



AL

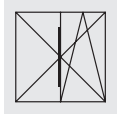
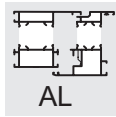

3

Double-sash drive rod GASM V < 700

- Central handle position with opposing eurogroove
- Locking gap less than 700 mm (V < 700)
- 1 piece
- Clampable in fitting groove
- Concealed lever, easily accessible
- 1-piece locking stroke similar to drive rod GAK or GAM
- Safety keeps are generally pre-assembled
- Adapters for functional parts DFE and TFE can be fitted to security keeps - from GASM.1050-1 onwards (not applicable to activPilot Comfort!)

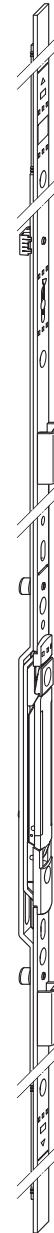

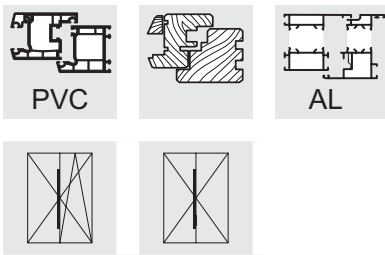

Item description	Item No.	Scope of application		VPA1 Qty./Type	VPA2 Qty./Type	VPA3 Qty./Type
GASM.1400-2	4933668	FFH 900 - 1400	5	10 BD	400 L1	
GASM.1800-2	4933700	FFH 1300 - 1800	7	10 BD	400 L1	
GASM.2300-3	4933701	FFH 1800 - 2300	9	10 BD	400 L2	900 EU2

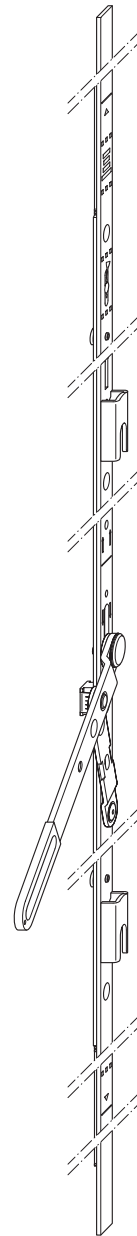

Double-sash drive rod GASM.GZ

- Central handle position with opposing eurogroove
- 1 piece
- 1-piece locking stroke similar to drive rod GAK or GAM
- Safety keeps are generally pre-assembled
- Adapters for functional components DFE and TFE can be installed in security keeps - from GASM.GZ.1400-1 (and up)
- Cutting is performed when open
- The GASM.GZ.800 drive rod is always fitted with E3 corner drive (bottom corner).
- Cannot be combined with backsets D7.5, D8.5 and D-6
- Not suitable for automatic screwing machines



Item description	Item No.	Scope of application		VPA1 Qty./Type	VPA2 Qty./Type	VPA3 Qty./Type
GASM.GZ.800.E3	4974991	FFH 530 - 800	3	10 BD	400 EA	
GASM.GZ.1050-1	4965127	FFH 710 - 1050	3	10 BD	400 EA	
GASM.GZ.1400-1	4965128	FFH 900 - 1400	4	10 BD	400 L1	
GASM.GZ.1400-2	4965129	FFH 900 - 1400	4	10 BD	400 L1	
GASM.GZ.1800-2	4965130	FFH 1300 - 1800	7	10 BD	400 L1	
GASM.GZ.2300-3	4965131	FFH 1800 - 2300	9	10 BD	400 L2	900 EU2

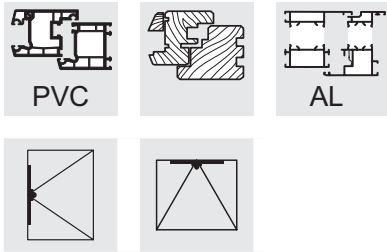

3

locking drive GAVM

- Cannot be coupled
- Central handle position
- Backset 15.5 mm
- 18.5 mm drive stroke when window handle is turned by 90°
- For drilling and milling instructions see Group 15 installation drawings B-3-1
- Gear case for milling from rebate
- Gear case for mounting in drilled hole
- Fasten the window handle attachment with M5 x ..., DIN 965, 43 mm screw centres

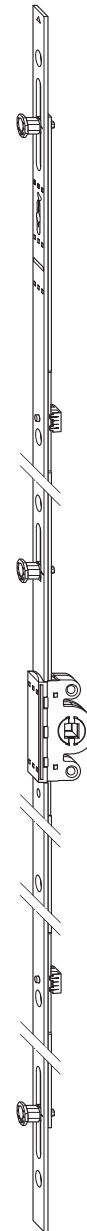

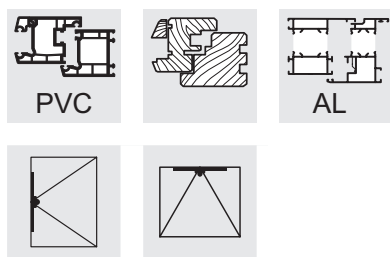

Item description	Item No.	Scope of application		VPA1 Qty./Type	VPA2 Qty./Type	VPA3 Qty./Type
GAVM.175-1	4927927	FFH/FFB 175 - 299	2	20 BD	400 EA	
GAVM.300-2	4927928	FFH/FFB 300 - 419	3	20 BD	400 EA	
GAVM.420-2	4927929	FFH/FFB 420 - 619	4	20 BD	400 EA	
GAVM.620-2	4927940	FFH/FFB 620 - 919	4	20 BD	400 EA	
GAVM.920-3	4927941	FFH/FFB 920 - 1219	6	20 BD	400 EA	
GAVM.1220-3	4996829	FFH/FFB 1220 - 1319	8	10 BD	400 L1	
GAVM.1320-3	4927942	FFH/FFB 1320 - 1519	8	10 BD	400 L1	
GAVM.1520-3	4996828	FFH/FFB 1520 - 1819	8	10 BD	400 L1	
GAVM.1820-4	4927943	FFH/FFB 1820 - 2019	10	10 BD	300 L2	
GAVM.2020-4	4996827	FFH/FFB 2020 - 2350	12	10 BD	300 L2	900 EU2

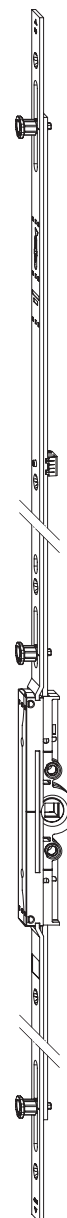

locking drive GAVM D7,5

- Cannot be coupled
- Central handle position
- Backset 7.5 mm
- 18.5 mm drive stroke when window handle is turned by 90°
- For drilling and milling instructions see group 15, installation drawings
- Gear case for milling from rebate
- Gear case for mounting in drilled hole
- Fasten the window handle attachment with M5 x ..., DIN 965, 43 mm screw centres



Item description	Item No.	Scope of application		VPA1 Qty./Type	VPA2 Qty./Type
GAVM.420-2.D7,5	5015492	FFH/FFB 420 - 619	4	20 BD	1200 E3
GAVM.620-2.D7,5	5015493	FFH/FFB 620 - 919	4	20 BD	1200 E3
GAVM.920-3.D7,5	5015494	FFH/FFB 920 - 1219	6	20 BD	1200 E3
GAVM.1220-3.D7,5	5015495	FFH/FFB 1220 - 1319	8	10 BD	400 L6
GAVM.1320-3.D7,5	5015496	FFH/FFB 1320 - 1519	8	10 BD	400 L6
GAVM.1520-3.D7,5	5015497	FFH/FFB 1520 - 1819	8	10 BD	300 L6
GAVM.1820-4.D7,5	5015498	FFH/FFB 1820 - 2019	10	10 BD	300 L7
GAVM.2020-4.D7,5	5015499	FFH/FFB 2020 - 2350	12	10 BD	300 L7

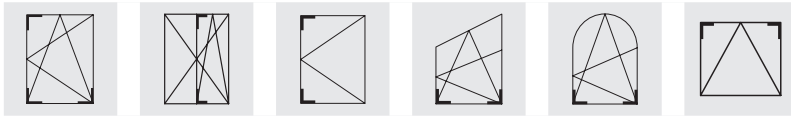

4

Corner drive E1

- Bracket length 98.5 mm
- Automatic and manual assembly possible
- Smooth operation, due to rust-free spring steel hinges inserted in C-rail

Corner drive E1.N

- Same version as E1, including supporting element to fix to the fitting groove of the sash.

Corner drive E6.N

- Designed as E1.N, but without octagonal locking bolt

Corner drive E11

- Same construction as E1 with an additional octagonal bolt on the second arm

Corner drive E11.F

- Clampable design

Corner drive E11.N

- Same version as E11, but including supporting element to fix to the fitting groove of the sash.

Corner drive E1.BS

- The components specially developed for threshold solutions (sash and frame side) can be gathered from the catalogue "Complementary range activPilot threshold components...".

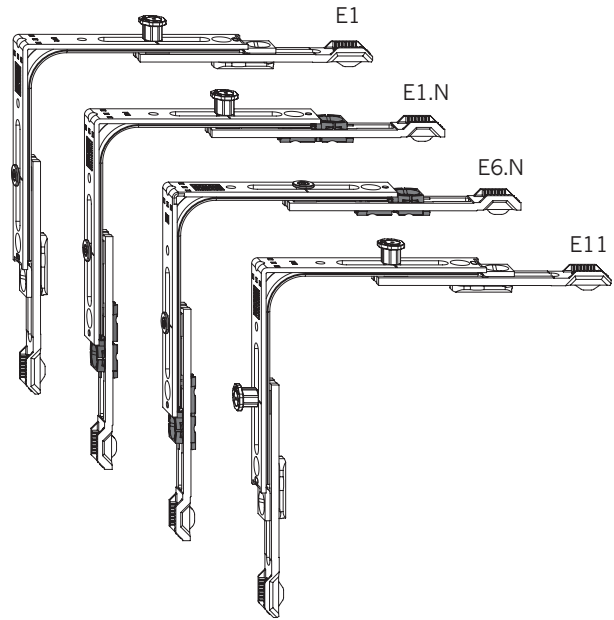

Item description	Item No.		VPA1 Qty./Type	VPA2 Qty./Type
E1	2841823	4	100 KK	2400 EK
E1.N	5019146	4	100 KK	2400 EK
E6.N	5066608	4	100 KK	2400 EK
E11	4936017	4	100 KK	2400 EK
E11.F	4942960	4	100 KK	2400 EK
E11.N	5051287	4	100 KK	2400 EK

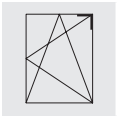
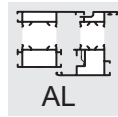
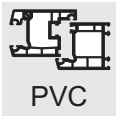

Corner drive E2

- Coupled with OS2 on the hinge side
- Bracket length 98.5 mm
- Automatic and manual assembly possible
- Smooth operation, due to rust-free spring steel hinges inserted in C-rail

Corner drive E2.N

- Same version as E2, including supporting element to fix to the fitting groove of the sash.

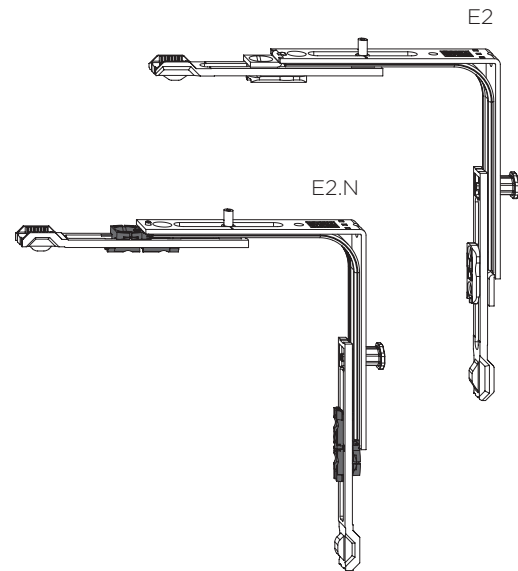

Item description	Item No.		VPA1 Qty./Type	VPA2 Qty./Type
E2	2842017	4	100 KK	2400 EK
E2.N	5019147	4	100 KK	2400 EK

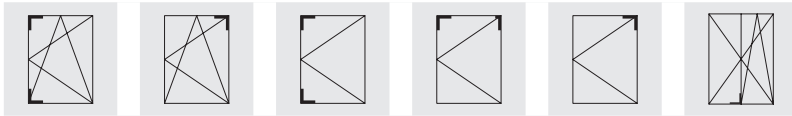

4

Corner drive E3

- Bracket length 98.5 mm (on one side)
- With shortened bracket on one side
- Automatic and manual assembly possible
- Smooth operation, due to rust-free spring steel hinges inserted in C-rail
- The screw for fixing the adjoining faceplate (on the short piece) with the corner drive is included in the scope of delivery.

Corner drive E3.F

- Same design as E3, but clampable in the fitting groove

Corner drive E3.L

- Automatic mounting carried out by Lemuth
- Corner piece for diagonal screw connection

Corner drive E3.FL

- Same design as E3.L, but clampable

Corner drive E3.0

- Design identical to E3, but without locking pin

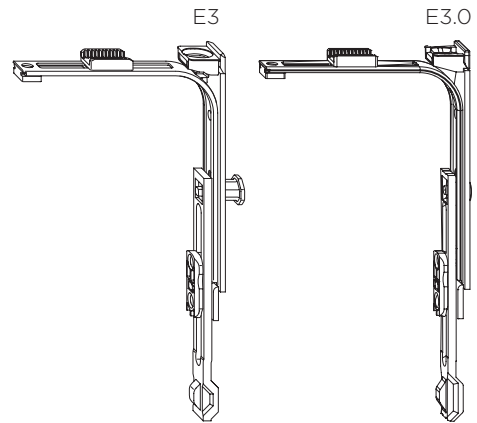

Item description	Item No.		VPA1 Qty./Type	VPA2 Qty./Type
E3	2842244	3	100 KK	2400 EK
E3.F	4929791	3	100 KK	2400 EK
E3.L	4927430	3	100 KK	2400 EK
E3.FL	5009086	3	100 KK	2400 EK
E3.0	5034800	3	100 KK	2400 EK

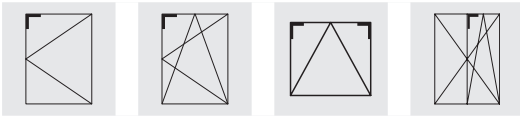
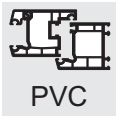

Corner drive E1.MSL

- Mini ventilation of approx. 7 to 20 mm is possible
- Engages into the frame part RT.MSL.3
- Bracket length 98.5 mm
- Smooth operation, due to rust-free spring steel hinges inserted in C-rail

Frame part RT.MSL.3

- Counterpart to interlock with E1.MSL, located on the frame
- For profile allocation see Group 11, frame parts

Sash part FT/EU.MSL.601

- Matching part on the sash for clicking in place the E1.MSL corner drive on double-sash windows
- To screw on the E1 corner drive of the inactive sash
- The indication of direction refers to the hinge side of the sash in question.
- For double-sash windows the E1.MSL.RS corner drive is combined with the sash part FT/EU.MSL.601 LS.

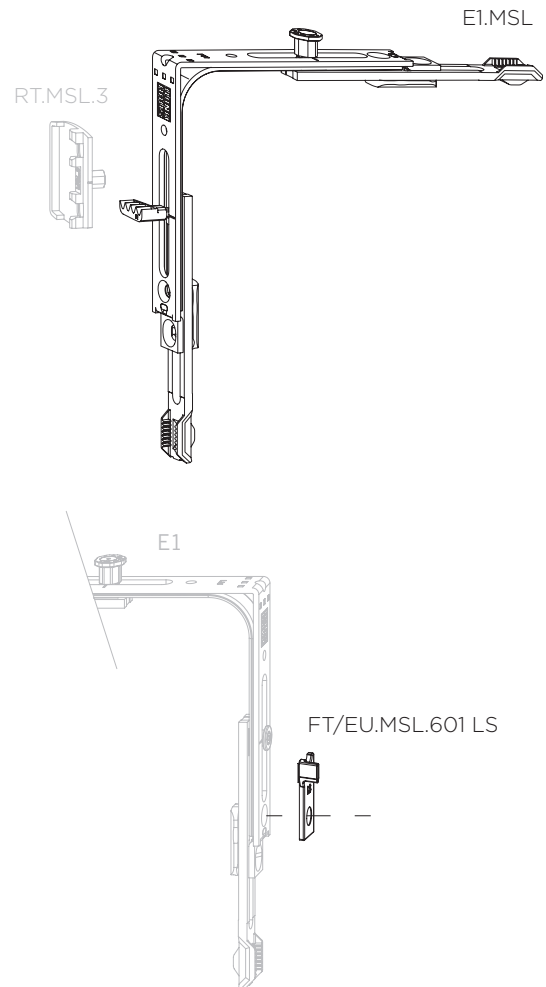

Item description	Item No.		VPA1 Qty./Type	VPA2 Qty./Type
E1.MSL.LS	5007005	4	100 KK	2400 EK
E1.MSL.RS	5007004	4	100 KK	2400 EK
FT/EU.MSL.601 LS	5025834	1	800 KK	6400 EK
FT/EU.MSL.601 RS	5025832	1	800 KK	6400 EK

RS = right, LS = left

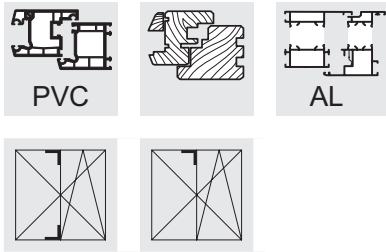

4

Corner drive E1.SBS

- For installation into the inactive (second-opening) sash with opposing eurogroove when an E11 corner drive is used for the sash opened first.
- With security keep welded to the vertical arm
- Bracket length 98.5 mm
- Automatic and manual assembly possible
- Smooth operation, due to rust-free spring steel hinges inserted in C-rail

Corner drive E1.SBS.O

- For installation into the inactive sash (top area)

Corner drive E1.SBS.U

- For installation into the inactive sash (bottom area)

Corner drive E1.SBS...F

- Clampable design

Corner drive E1.SBS.O.RC.F

- See above
- With slide lock (beneath the welded keep) against manipulation when the turn-tilt sash is locked.
- Clampable design

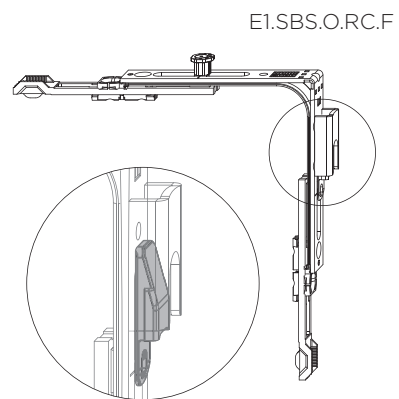
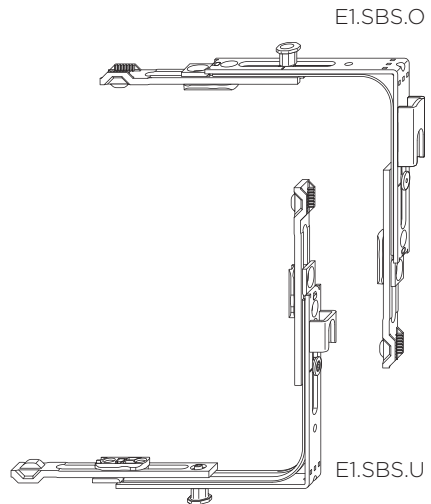

Item description	Item No.		VPA1 Qty./Type	VPA2 Qty./Type
E1.SBS.O	4964898	4	100 KK	2400 EK
E1.SBS.O.F	4964900	4	100 KK	2400 EK
E1.SBS.U	4964899	4	100 KK	2400 EK
E1.SBS.U.F	4964901	4	100 KK	2400 EK
E1.SBS.O.RC.F	5037101	4	100 KK	2400 EK

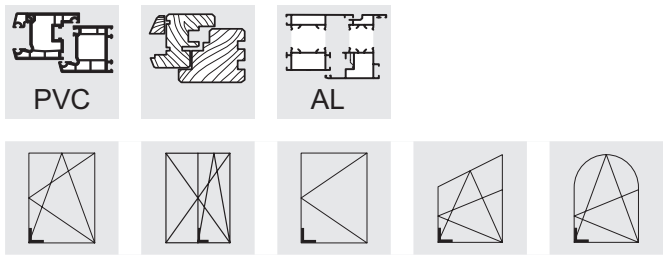

Corner drive E1.SP.N

- Bracket length 98.5 mm
- Safety locking pin as an adjustable octagonal bolt
- Smooth operation, due to rust-free spring steel hinges inserted in C-rail
- With welded steel cage
- In combination with frame parts SBK...SP for improved (increased) burglary resistance

Corner drive E11.SP.N

- Same construction as E1.SP.N with an additional octagonal bolt on the second arm

Corner drive E3.ZN.SP.F

- Identical to corner drive E3.F.L
- With welded steel cage

Security tilt keep SBK..SP..

- SP security tilt keep with safety bolt for active locking with corner drive E..SP.N
- Integrated support keep for easy closing of the window sash
- Can be used left and right hand
- Quick assembly thanks to direct positioning in the frame rebate corner
- Easy integration into the production process, because no jigs are needed for assembly
- For profile allocation see Group 11, frame parts

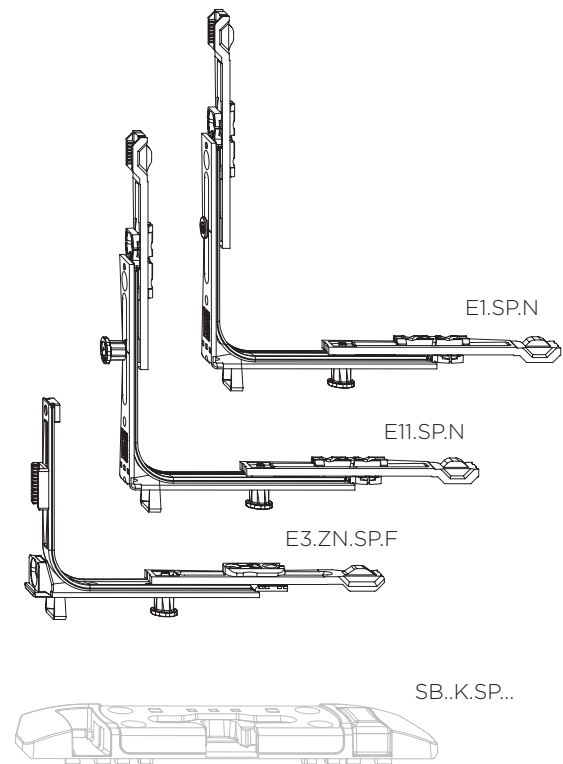

Item description	Item No.		VPA1 Qty./Type	VPA2 Qty./Type
E1.SP.N	5051288	4	100 KK	2400 EK
E11.SP.N	5051289	4	100 KK	2400 EK
E3.ZN.SP.F	5010271	3	100 KK	2400 EK

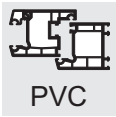

PVC



AL

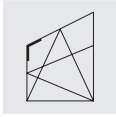
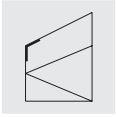

4

Corner drive E1.A

- Used for non right-angled corners on sashes
- Adjustable angle setting
- Smooth operation, due to rust-free spring steel hinges inserted in C-rail

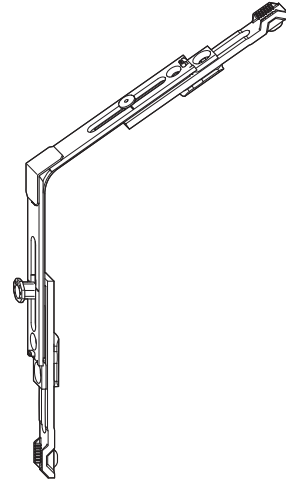

Item description	Item No.		VPA1 Qty./Type	VPA2 Qty./Type
E1.A	4926350	4	100 KK	2400 EK

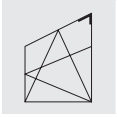
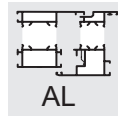
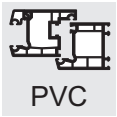

Connecting rail ASS AR 7/OR-A SL

- In combination with OS2. ... for studio windows
- Airgap 12 mm
- For non square edges in the shear area

Screw clip OS.A

- Only in combination with OS1.600 for studio windows
- The screw clip is led through the last top rod screw hole and is screwed in the vertical fitting groove.

Connecting rail ASS.AS.1

- For turn windows in combination with drive rod GAM or GAK
- Not suited for turn-tilt windows
- Use the stop piece ANS ACP or stroke limiter AWDR SL for stroke limitation.

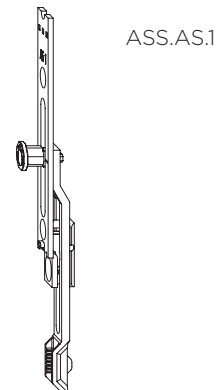
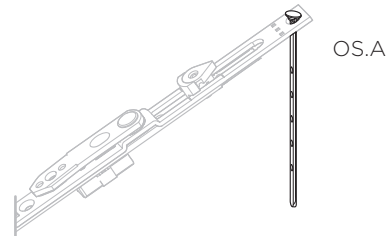
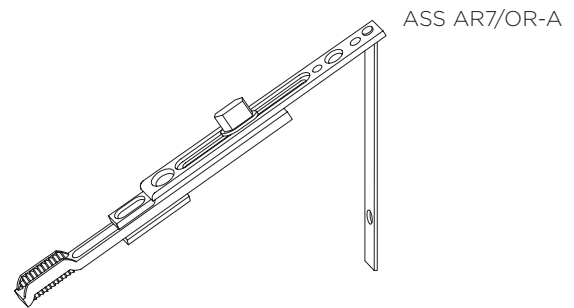

Item description	Item No.		VPA1 Qty./Type	VPA2 Qty./Type	VPA3 Qty./Type
ASS AR 7/OR-A SL	1811091	2	10 BD	150 KK	1200 EK
OS.A	5000283	1	50 BL	1000 KK	8000 EK
ASS.AS.1	4937603	2	150 KK	3600 EK	

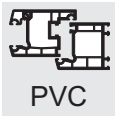

PVC



AL

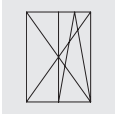

4

Connecting rails

Connecting rail ASS.SP - 1

- Including rod design and shortened bracket for narrow patio doors
- To enable handicapped persons locking of low threshold doors with ground sleeves
- Without run-up block
- With security locking pin designed as adjustable octagonal locking bolt
- For turn-tilt doors at the bottom locking point (gear side)
- Connection of interlocking rod is not possible

Connecting rail ASS.SP - 1.18

- Same design as ASS.SP - 1, but with 18 mm rod extension

Connecting rail ASS.SP.GGL.SB

- Same design as ASS.SP-1
- For turn double-sash doors, in combination with ASS.SP-1
- Installed security keep

Connecting rail ASS.SP.GGL.SB.18

- Same design as ASS.SP.GGL.SP, but with 18 mm rod extension
- For turn double-sash doors, in combination with ASS.SP-1

Connecting rail ASS.SP

- Including rod design and shortened bracket for narrow patio doors
- For turn-only doors (top locking point)
- Connection of interlocking rod is not possible

Connecting rail ASS.SP.GGL

- Same design as ASS.SP
- With return stroke if used on turn and turn-double sashes at the bottom locking point
- To enable handicapped persons locking of low threshold doors with ground sleeves

Ground sleeve BH 17/20 SL

- Used to drill into low thresholds
- Diameter 17mm; length 20 mm

Ground sleeve BH 17/30 SL

- As described above, but with dust seal
- Diameter 17 mm; length 30 mm

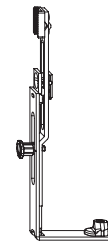

ASS.SP - 1
ASS.SP - 1.18

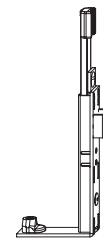

ASS.SP.GGL.SB
ASS.SP.GGL.SB.18



ASS.SP



ASS.SP.GGL



BH 17/20 SL



BH 17/30 SL

Item description	Item No.	Scope of application		VPA1 Qty./Type	VPA2 Qty./Type	VPA3 Qty./Type
ASS.SP-1	5019459	FFH > 420 mm	2	150 KK	1200 EK	
ASS.SP-1.18	5030253	FFH > 420 mm	2	150 KK	1200 EK	
ASS.SP.GGL.SB	5019457	FFH > 420 mm	2	150 KK	1200 EK	
ASS.SP.GGL.SB.18	5030252	FFH > 420 mm	2	150 KK	1200 EK	
ASS.SP	5019458	FFH > 420 mm	2	150 KK	1200 EK	
ASS.SP.GGL	5019455	FFH > 420 mm	2	150 KK	1200 EK	
BH 17/20 SL	2309087		0	20 BL	200 KK	1600 EK
BH 17/30 SL	1885242		0	20 BL	200 KK	1600 EK

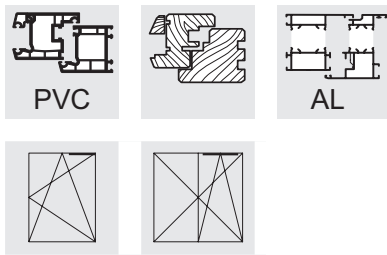

Top rod OS1.600

- In combination with shears SK1/SH1/SHW1/SC1
- OS1.600 is always combined with an E3 corner drive on the hinge side
- Integrated anti-slam block in tilt position as standard
- Progressive shear retraction: adjustable from 18 to 25 mm
- After assembly the top rod and the shear are firmly attached to one another
- Clampable in fitting groove
- Variable tilt device MSL.OS as retrofit option for window profiles with a frame rebate depth of 25 mm

Top Rod OS ... MSL

- With pre-assembled variable tilt device
- Progressive shear retraction 18 mm
- (Frame rebate depth at least 25 mm)

Top Rod OS ... ZSS

- With pre-assembled anti-slam device

Variable tilt device MSL-OS

- See Group 10, accessories

Tilt limiter KBG.OS1

- See Group 10, accessories

Anti slam device ZSS.OS1

- See Group 10, accessories

Item description	Item No.	Scope of application		VPA1 Qty./Type	VPA2 Qty./Type
OS1.600	2847141	FFB 370 - 600	3	20 BD	800 EA
OS1.600.MSL.LS	4926908	FFB 370 - 600	3	20 BD	800 EA
OS1.600.MSL.RS	4926906	FFB 370 - 600	3	20 BD	800 EA
OS1.600.ZSS	4938601	FFB 370 - 600	3	20 BD	800 EA

RS = right, LS = left

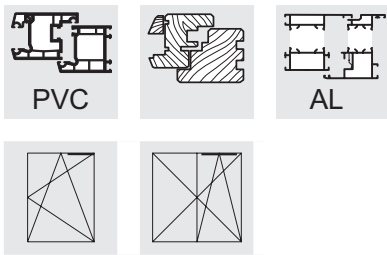

5

Top rod OS2

- OS2 ... is used in combination with E2 on the hinge side
- In combination with shears SK2/SH2/SHW2/SC2
- After assembly the top rod and the shear are firmly attached to one another
- Clampable in fitting groove
- Progressive shear retraction: adjustable from 18 to 25 mm
- Integrated anti-slam block in tilt position as standard
- From 1475 mm sash rebate width with additional shear ZSR
- Variable tilt device MSL.OS as retrofit option for window profiles with a frame rebate depth of 25 mm and 9 mm eurogroove position

Top Rod OS ... MSL

- With pre-assembled variable tilt device
- Progressive shear retraction 18 mm
- (Frame rebate depth at least 25 mm)

Top Rod OS ... ZSS

- With pre-assembled anti-slam device

Variable tilt device MSL-OS

- See Group 10, accessories

Tilt limiter KBG.OS

- See Group 10, accessories

Anti-slam device ZSS.OS

- See Group 10, accessories

Item description	Item No.	Scope of application		VPA1 Qty./Type	VPA2 Qty./Type
OS2.800	4928979	FFB 600 - 800	4	20 BD	800 EA
OS2.800.MSL.LS	4928986	FFB 600 - 800	4	20 BD	800 EA
OS2.800.MSL.RS	4928987	FFB 600 - 800	4	20 BD	800 EA
OS2.800.ZSS	4937413	FFB 600 - 800	4	20 BD	800 EA
OS2.1025	2849278	FFB 775 - 1025	5	20 BD	500 EA
OS2.1025-1	2848275	FFB 775 - 1025	5	20 BD	500 EA
OS2.1025-1.MSL.LS	4926913	FFB 775 - 1025	5	20 BD	500 EA
OS2.1025-1.MSL.RS	4926912	FFB 775 - 1025	5	20 BD	500 EA
OS2.1025-1.ZSS	4937450	FFB 775 - 1025	5	20 BD	500 EA
OS2.1250-1	2848291	FFB 1000 - 1250	6	20 BD	500 EA
OS2.1250-1.MSL.LS	4926915	FFB 1000 - 1250	6	20 BD	500 EA
OS2.1250-1.MSL.RS	4926914	FFB 1000 - 1250	6	20 BD	500 EA
OS2.1250-1.ZSS	4937451	FFB 1000 - 1250	6	20 BD	500 EA
OS2.1475-1	2848304	FFB 1225 - 1475	6	20 BD	500 LI
OS2.1475-1.ZSS	4937454	FFB 1225 - 1475	6	20 BD	500 LI

RS = right, LS = left

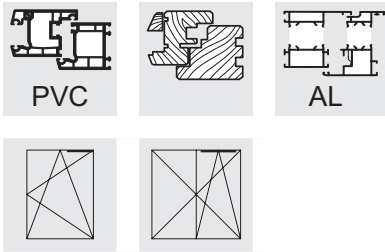

Top rod OS ... E

- For the type of fitting "Tilt before turn"
- In combination with SK/SH/SC.E shears
- From 1250 mm sash rebate width with additional shear ZSRE
- After assembly the top rod and the shear are firmly attached to one another
- Clampable in fitting groove
- Tilt position is the factory default

Tilt limiter KBG.OS

- See Group 10, accessories

Anti-slam device ZSS.OS

- See Group 10, accessories

Item description	Item No.	Scope of application		VPA1 Qty./Type	VPA2 Qty./Type
OS1.600.E	4926108	FFB 370 - 600	3	20 BD	800 EA
OS2.800.E	4928985	FFB 600 - 800	4	20 BD	800 EA
OS2.1025-1.E	4926177	FFB 775 - 1025	5	20 BD	500 EA
OS2.1250-1.E	4926178	FFB 1000 - 1250	6	20 BD	500 EA
OS2.1475-1.E	4926180	FFB 1225 - 1475	6	20 BD	500 L1

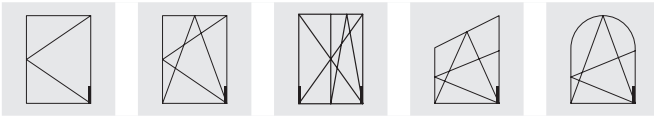
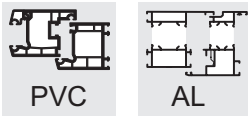

Corner hinge EL.K

6

- Used in combination with sash hinges FL.K... or FL.KA...
- Corner hinge EL.K with symmetrical drill holes to match shear hinge SL.KS
- In case of sash overlap of 20 mm: corner hinge and cap flush with the lower edge of the sash
- Drilling template see Group 15, installation drawings B-6-3
- Side adjustment ±2 mm
- Can be used left and right hand
- For sash weight see overview of articles

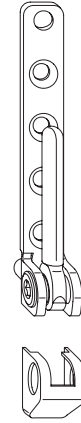

Corner hinge cap ELK ESV

- Can be used left and right hand

Item description	Item No.		Max. sash weight (kg)	VPA1 Qty./Type	VPA2 Qty./Type	VPA3 Qty./Type
EL.K.3-3-3	4926256	4	80	400 KK	9600 EK	
EL.K.3-3-3.WS	4928409	4	80	400 KK	9600 EK	
EL.K.3-3-3.BR	4938886	4	80	400 KK	3200 EK	
EL.K.3-3-3.CW	4938887	4	80	400 KK	3200 EK	
EL.K.3-3-3.F9	4938888	4	80	400 KK	3200 EK	
EL.K.6-3-3	4926937	4	80	400 KK	3200 EK	
EL.K.6-3-3.WS	4926936	4	80	400 KK	3200 EK	
EL.K.6-3-3.BR	4926939	4	80	400 KK	3200 EK	
EL.K.6-3-3.F9	4926938	4	80	400 KK	3200 EK	
EL.K.6-3-10	4932434	4	100	400 KK	9600 EK	
EL.K.6-3-10.WS	4932435	4	100	400 KK	9600 EK	
EL.K.6-3-10.BR	4932437	4	100	400 KK	3200 EK	
EL.K.6-3-10.F9	4932436	4	100	400 KK	9600 EK	
EL.K.6-3-16	2844602	4	100	400 KK	9600 EK	
EL.K.6-3-16.WS	2844637	4	100	400 KK	9600 EK	
EL.K.6-3-16.BR	4926830	4	100	400 KK	3200 EK	
EL.K.6-3-16.CW	4928066	4	100	400 KK	3200 EK	
EL.K.6-3-16.F9	2844653	4	100	400 KK	9600 EK	
EL.K.6-3-16.LBR	5002889	4	100	400 KK	9600 EK	
EL.K.6-3-16.LGR	5002888	4	100	400 KK	9600 EK	
EL.K.6-3-16.PW	5002887	4	100	400 KK	9600 EK	
EL.K.6-16-3	4993871	4	100	400 KK	3200 EK	
EL.K.6-16-3.BR	4993874	4	100	400 KK	3200 EK	
EL.K.6-16-3.WS	4993872	4	100	400 KK	3200 EK	
EL.K.6-16-3.F9	5020821	4	100	400 KK	3200 EK	
ELK ESV BR	4990531			200 BL	2000 KK	16000 EK
ELK ESV BZ-AM	4990539			100 BL	1000 KK	8000 EK
ELK ESV BZ-RB	4990590			100 BL	1000 KK	8000 EK
ELK ESV CW	4990533			100 BL	1000 KK	8000 EK
ELK ESV F1	4990535			100 BL	1000 KK	8000 EK
ELK ESV F3	4995111			100 BL	1000 KK	8000 EK
ELK ESV F3-MG	4990537			100 BL	1000 KK	8000 EK
ELK ESV F9	4990530			100 BL	1000 KK	8000 EK
ELK ESV LBR	4990532			100 BL	1000 KK	8000 EK
ELK ESV LGR	5002840			100 BL	300 KK	2400 EK
ELK ESV PW	5002833			100 BL	300 KK	2400 EK
ELK ESV SW	4990538			200 BL	2000 KK	16000 EK
ELK ESV WS	4990509			200 BL	2000 KK	48000 EK

AGR = anthracite grey, BR = brown, BZ-AM = bronze - antique brass, BZ-RB = bronze - red brown, BZ-CU = bronze coppery, CW = creme white, EV1 = anodised silver, F1 = silver colour, F1-elox = sim. to F1 anodised silver, F3 = gold colour, F3-MG = gold mat, F9 = titanium coloured, LBR = clay brown, PW = pearl white, SG = silver grey, SGB = grey, SGR = dusty grey, SL = silver look (zinc galvanised), SW = jet black, WS = white

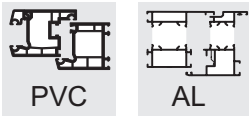

Corner hinge EL.KB

- Used in combination with sash hinges FL.K... or FL.KA...
- Side adjustment ±2 mm
- In case of sash overlap of 20 mm: corner hinge and cap flush with the lower edge of the sash
- Drilling template see Group 15, installation drawings B-6-3
- Non-handed

Corner hinge cover ELK ESVW

- Non-handed

Attention: For screwing in place the load-bearing fitting parts, such as corner hinges, shear and sash hinges, the TBDK guideline must be adhered to.

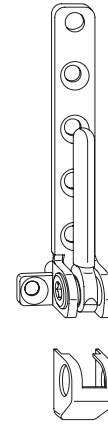

Item description	Item No.		Max. sash weight (kg)	VPA1 Qty./Type	VPA2 Qty./Type	VPA3 Qty./Type
EL.KB.6-3-16.LS	4926920	5	130	400 KK	3200 EK	
EL.KB.6-3-16.RS	4926919	5	130	400 KK	3200 EK	
EL.KB.6-3-16.LS.WS	2903959	5	130	400 KK	3200 EK	
EL.KB.6-3-16.RS.WS	2903879	5	130	400 KK	3200 EK	
EL.KB.6-3-16.LS.F9	2903983	5	130	400 KK	3200 EK	
EL.KB.6-3-16.RS.F9	2903967	5	130	400 KK	3200 EK	
EL.KB.6-3-16.LS.BZ-CU	5009538	5	130	400 KK	3200 EK	
EL.KB.6-3-16.RS.BZ-CU	5009537	5	130	400 KK	3200 EK	
ELK ESVW LS WS	4990471			100 BL	1000 KK	8000 EK
ELK ESVW RS WS	4990500			100 BL	1000 KK	8000 EK
ELK ESVW LS BR	4990473			100 BL	1000 KK	8000 EK
ELK ESVW RS BR	4990502			100 BL	1000 KK	8000 EK
ELK ESVW LS F1	4990476			100 BL	1000 KK	8000 EK
ELK ESVW RS F1	4990505			100 BL	1000 KK	8000 EK
ELK ESVW LS F3	4990478			100 BL	1000 KK	8000 EK
ELK ESVW RS F3	4990506			100 BL	1000 KK	8000 EK
ELK ESVW LS F9	4990472			100 BL	1000 KK	8000 EK
ELK ESVW RS F9	4990501			100 BL	1000 KK	8000 EK

RS = right, LS = left

AGR = anthracite grey, BR = brown, BZ-AM = bronze - antique brass, BZ-RB = bronze - red brown, BZ-CU = bronze coppery, CW = creme white, EV1 = anodised silver, F1 = silver colour, F1-elox = sim. to F1 anodised silver, F3 = gold colour, F3-MG = gold mat, F9 = titanium coloured, LBR = clay brown, PW = pearl white, SG = silver grey, SGB = grey, SGR = dusty grey, SL = silver look (zinc galvanised), SW = jet black, WS = white

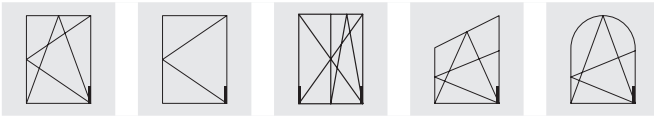
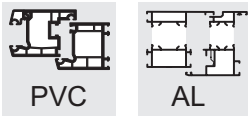

Corner hinge ESV

- Used in combination with sash hinges FL.K.20-6-28.130, FWV..., FLE...PA.. or FK-F...
- Can be used left and right hand
- ESV corner hinge with symmetrical drilling pattern, according to shear hinge SL.KS.3-6
- Corner hinge/shear hinge drilling possible on loose pieces
- Side adjustment ± 2 mm
- Max. sash weight 100 kg; 130 kg on request (ESV 6-3-16)
- In case of sash overlap of 20 mm: corner hinge and cap flush with the lower edge of the sash
- For drill and screw templates see group 15, installation drawings B-6-3

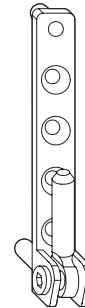

Corner hinge cap ELK ESV

- Can be used left and right hand



Attention: For screwing in place the load-bearing fitting parts, such as corner hinges, shear and sash hinges, the TBDK guideline must be adhered to.

Item description	Item No.		Max. sash weight (kg)	VPA1 Qty./Type	VPA2 Qty./Type	VPA3 Qty./Type
ESV 3-3-3 SL	1939503	4	80	400 KK	3200 EK	
ESV 3-3-3 SL/BR	1934711	4	80	400 KK	3200 EK	
ESV 3-3-3 SL/WS	2067604	4	80	400 KK	3200 EK	
ESV 6-3-3 SL	1846551	4	100	400 KK	3200 EK	
ESV 6-3-3 SL/BR	2071267	4	100	400 KK	3200 EK	
ESV 6-3-3 SL/F9	4983321	4	100	400 KK	3200 EK	
ESV 6-3-3 SL/WS	2071283	4	100	400 KK	3200 EK	
ESV 6-3-10 SL	2595571	4	100	400 KK	9600 EK	
ESV 6-3-10 SL/F9	4949435	4	100	400 KK	9600 EK	
ESV 6-3-10 SL/WS	2583975	4	100	400 KK	3200 EK	
ESV 6-3-16 SL	1898609	4	100/130	400 KK	9600 EK	
ESV 6-3-16 SL/BR	1930488	4	100/130	400 KK	9600 EK	
ESV 6-3-16 SL/CW	2548707	4	100/130	400 KK	3200 EK	
ESV 6-3-16 SL/F9	2010481	4	100/130	400 KK	9600 EK	
ESV 6-3-16 SL/WS	1930470	4	100/130	400 KK	9600 EK	
ESV 6-16-16 SL/WS	2051274	4	100/130	400 KK	3200 EK	
ELK ESV WS	4990509			200 BL	2000 KK	48000 EK
ELK ESV BR	4990531			200 BL	2000 KK	16000 EK
ELK ESV BZ-AM	4990539			100 BL	1000 KK	8000 EK
ELK ESV BZ-RB	4990590			100 BL	1000 KK	8000 EK
ELK ESV CW	4990533			100 BL	1000 KK	8000 EK
ELK ESV F1	4990535			100 BL	1000 KK	8000 EK
ELK ESV F3	4995111			100 BL	1000 KK	8000 EK
ELK ESV F3-MG	4990537			100 BL	1000 KK	8000 EK
ELK ESV F9	4990530			100 BL	1000 KK	8000 EK
ELK ESV SW	4990538			200 BL	2000 KK	16000 EK
ELK ESV LBR	4990532			100 BL	1000 KK	8000 EK
ELK ESV PW	5002833			100 BL	300 KK	2400 EK
ELK ESV LGR	5002840			100 BL	300 KK	2400 EK
ELK ESV F1-ELOX.	5021122			100 BL	1000 K3	8000 E3

AGR = anthracite grey, BR = brown, BZ-AM = bronze - antique brass, BZ-RB = bronze - red brown, BZ-CU = bronze coppery, CW = creme white, EV1 = anodised silver, F1 = silver colour, F1-elox = sim. to F1 anodised silver, F3 = gold colour, F3-MG = gold mat, F9 = titanium coloured, LBR = clay brown, PW = pearl white, SG = silver grey, SGB = grey, SGR = dusty grey, SL = silver look (zinc galvanised), SW = jet black, WS = white

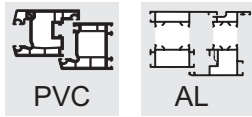

Corner hinge ESVW

- Used in combination with sash hinges FL.K.20-6-28.130, FWV..., FL.E...PA.. or FK-F...
- Side adjustment ±2 mm
- Max. sash weight 130 kg
- For drill and screw templates see group 15, installation drawings B-6-3

Corner hinge cover ELK ESVW

- Non-handed

Attention: For screwing in place the load-bearing fitting parts, such as corner hinges, shear and sash hinges, the TBDK guideline must be adhered to.

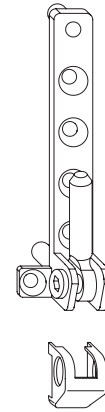

Item description	Item No.		Max. sash weight (kg)	VPA1 Qty./Type	VPA2 Qty./Type	VPA3 Qty./Type
ESVW 6-3-16 LS SL/WS	1934737	5	130	400 KK	3200 EK	
ESVW 6-3-16 RS SL/WS	1934788	5	130	400 KK	3200 EK	
ESVW 6-3-16 LS SL/F9	4978704	5	130	400 KK	3200 EK	
ESVW 6-3-16 RS SL/F9	4978703	5	130	400 KK	3200 EK	
ELK ESVW LS WS	4990471			100 BL	1000 KK	8000 EK
ELK ESVW RS WS	4990500			100 BL	1000 KK	8000 EK
ELK ESVW LS BR	4990473			100 BL	1000 KK	8000 EK
ELK ESVW RS BR	4990502			100 BL	1000 KK	8000 EK
ELK ESVW LS F1	4990476			100 BL	1000 KK	8000 EK
ELK ESVW RS F1	4990505			100 BL	1000 KK	8000 EK
ELK ESVW LS F3	4990478			100 BL	1000 KK	8000 EK
ELK ESVW RS F3	4990506			100 BL	1000 KK	8000 EK
ELK ESVW LS F9	4990472			100 BL	1000 KK	8000 EK
ELK ESVW RS F9	4990501			100 BL	1000 KK	8000 EK
ELK ESVW LS F1-ELOX.	5021126			100 BL	1000 K3	8000 E3
ELK ESVW RS F1-ELOX.	5021127			100 BL	1000 K3	8000 E3

AGR = anthracite grey, BR = brown, BZ-AM = bronze - antique brass, BZ-RB = bronze - red brown, BZ-CU = bronze coppery, CW = creme white, EV1 = anodised silver, F1 = silver colour, F1-elox = sim. to F1 anodised silver, F3 = gold colour, F3-MG = gold mat, F9 = titanium coloured, LBR = clay brown, PW = pearl white, SG = silver grey, SGB = grey, SGR = dusty grey, SL = silver look (zinc galvanised), SW = jet black, WS = white

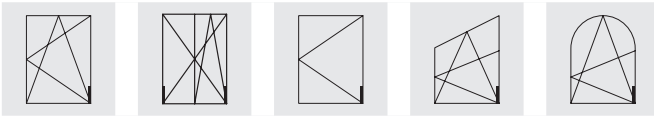
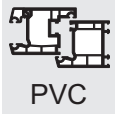

Sash hinge FL.K

- Used in combination with corner hinges EL.K... or EL.KB...
- Can be used left and right hand
- Height adjustment ± 3 mm

Sash hinge plug S.FL.K

- Can be used left and right hand

Sash hinge cover K.FL.K

- Can be used left and right hand

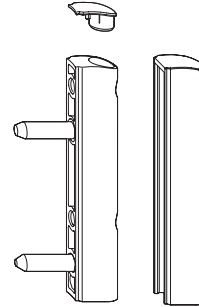

6

Item description	Item No.		Max. sash weight (kg)	VPA1 Qty./Type	VPA2 Qty./Type	VPA3 Qty./Type
FL.K.20-6-20	4928429	2	100	250 KK	6000 EK	
FL.K.20-6-20.WS	4928434	2	100	250 KK	6000 EK	
FL.K.20-6-20.BR	4928437	2	100	250 KK	2000 EK	
FL.K.20-6-20.CW	4928438	2	100	250 KK	2000 EK	
FL.K.20-6-20.F9	4928436	2	100	250 KK	6000 EK	
FL.K.20-6-28	2919459	2	100	250 KK	2000 EK	
FL.K.20-6-28.WS	2919475	2	100	250 KK	2000 EK	
FL.K.20-6-28.BR	4926827	2	100	250 KK	2000 EK	
FL.K.20-6-28.CW	4928065	2	100	250 KK	6000 EK	
FL.K.20-6-28.F9	2919491	2	100	250 KK	2000 EK	
K.FL.K.WS	2846552			100 BL	300 KK	7200 EK
K.FL.K.BR	4927425			100 BL	300 KK	7200 EK
K.FL.K.CW	4927562			100 BL	300 KK	2400 EK
K.FL.K.F1	4928486			100 BL	300 KK	2400 EK
K.FL.K.F3	4995090			100 BL	300 KK	2400 EK
K.FL.K.BZ-RB	4933298			100 BL	300 KK	2400 EK
K.FL.K.F9	2846561			100 BL	300 KK	2400 EK
K.FL.K.LBR	4939037			100 BL	300 KK	2400 EK
K.FL.K.F3-MG	4987481			100 BL	300 KK	2400 EK
K.FL.K.PW	5002865			100 BL	300 KK	2400 EK
K.FL.K.LGR	5002871			100 BL	300 KK	2400 EK
K.FL.K.SW RAL9005	4939058			100 BL	300 KK	2400 EK
K.FL.K.F1-ELOX.	5021121			100 BL	300 K3	7200 E3
S.FL.K.WS	2846536			500 BL	3000 KK	72000 EK
S.FL.K.BR	4927423			500 BL	3000 KK	72000 EK
S.FL.K.CW	4928081			500 BL	3000 KK	72000 EK
S.FL.K.F1	4935041			500 BL	3000 KK	24000 EK
S.FL.K.F9	2846544			500 BL	3000 KK	72000 EK

AGR = anthracite grey, BR = brown, BZ-AM = bronze - antique brass, BZ-RB = bronze - red brown, BZ-CU = bronze coppery, CW = creme white, EV1 = anodised silver, F1 = silver colour, F1-elox = sim. to F1 anodised silver, F3 = gold colour, F3-MG = gold mat, F9 = titanium coloured, LBR = clay brown, PW = pearl white, SG = silver grey, SGB = grey, SGR = dusty grey, SL = silver look (zinc galvanised), SW = jet black, WS = white

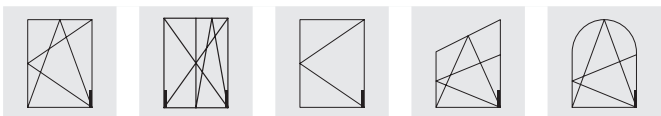
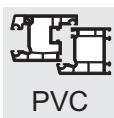

Sash hinge FL.KA

- Used in combination with corner hinges EL.K... or EL.KB...
- Can be used left and right hand
- Height adjustment ± 3 mm
- With contact pressure adjustment ± 1.2 mm

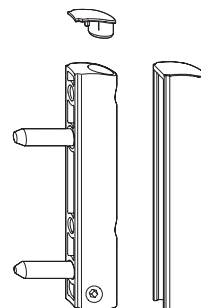

Sash hinge plug S.FL.K

- Can be used left and right hand

Sash hinge cover K.FL.K

- Can be used left and right hand

Item description	Item No.		Max. sash weight (kg)	VPA1 Qty./Type	VPA2 Qty./Type	VPA3 Qty./Type
FL.KA.20-6-20	2844661	2	100	250 KK	6000 EK	
FL.KA.20-6-20.WS	2844670	2	100	250 KK	6000 EK	
FL.KA.20-6-20.BR	4928443	2	100	250 KK	2000 EK	
FL.KA.20-6-20.CW	4928063	2	100	250 KK	2000 EK	
FL.KA.20-6-20.F9	2844688	2	100	250 KK	6000 EK	
FL.KA.20-6-28	4926186	2	100	250 KK	6000 EK	
FL.KA.20-6-28.WS	4926171	2	100	250 KK	6000 EK	
FL.KA.20-6-28.BR	4926826	2	100	250 KK	2000 EK	
FL.KA.20-6-28.F9	4926170	2	100	250 KK	2000 EK	
FL.KA.20-6-20.BZ-CU	5009536	2	100	250 KK	6000 EK	
K.FL.K.WS	2846552			100 BL	300 KK	7200 EK
K.FL.K.BR	4927425			100 BL	300 KK	7200 EK
K.FL.K.CW	4927562			100 BL	300 KK	2400 EK
K.FL.K.F1	4928486			100 BL	300 KK	2400 EK
K.FL.K.F3	4995090			100 BL	300 KK	2400 EK
K.FL.K.F3-MG	4987481			100 BL	300 KK	2400 EK
K.FL.K.BZ-RB	4933298			100 BL	300 KK	2400 EK
K.FL.K.F9	2846561			100 BL	300 KK	2400 EK
K.FL.K.LBR	4939037			100 BL	300 KK	2400 EK
K.FL.K.SW RAL9005	4939058			100 BL	300 KK	2400 EK
S.FL.K.WS	2846536			500 BL	3000 KK	72000 EK
S.FL.K.BR	4927423			500 BL	3000 KK	72000 EK
S.FL.K.CW	4928081			500 BL	3000 KK	72000 EK
S.FL.K.F1	4935041			500 BL	3000 KK	24000 EK
S.FL.K.F9	2846544			500 BL	3000 KK	72000 EK

AGR = anthracite grey, BR = brown, BZ-AM = bronze - antique brass, BZ-RB = bronze - red brown, BZ-CU = bronze coppery, CW = creme white, EV1 = anodised silver, F1 = silver colour, F1-elox = sim. to F1 anodised silver, F3 = gold colour, F3-MG = gold mat, F9 = titanium coloured, LBR = clay brown, PW = pearl white, SG = silver grey, SGB = grey, SGR = dusty grey, SL = silver look (zinc galvanised), SW = jet black, WS = white

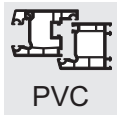

PVC

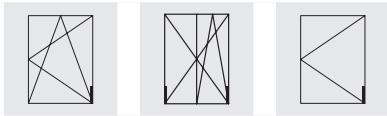

Sash hinge FL.K.20-6-28.130

- Used in combination with corner hinge ESV.6-3-16, max. sash weight 100 kg; 130 kg on request (subject to profile)
- Used in combination with corner hinge ESVW.6-3-16, max. sash weight 130 kg
- Can be used left and right hand
- Height adjustment ± 3 mm

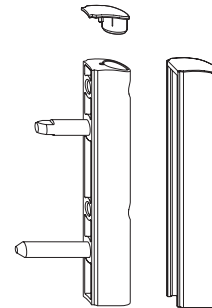

6

Sash hinge plug S.FL.K

- Can be used left and right hand

Sash hinge cap K.FL.K.130

- Can be used left and right hand

Item description	Item No.		Max. sash weight (kg)	VPA1 Qty./Type	VPA2 Qty./Type	VPA3 Qty./Type
FL.K.20-6-28.130	4987907	2	100/130	250 KK	2000 EK	
FL.K.20-6-28.130.BR	4995561	2	100/130	250 KK	2000 EK	
FL.K.20-6-28.130.F9	4995560	2	100/130	250 KK	2000 EK	
FL.K.20-6-28.130.WS	4995559	2	100/130	250 KK	2000 EK	
K.FL.K.130.F3-MG	5014722			100 BL	300 KK	2400 EK
K.FL.K.130.WS	4987940			100 BL	300 KK	2400 EK
K.FL.K.130.BR	4987947			100 BL	300 KK	2400 EK
K.FL.K.130.F1	4987949			100 BL	300 KK	2400 EK
K.FL.K.130.CW	4987951			100 BL	300 KK	2400 EK
K.FL.K.130.F1-ELOX.	5021125			100 BL	300 K3	2400 E3
S.FL.K.WS	2846536			500 BL	3000 KK	72000 EK
S.FL.K.BR	4927423			500 BL	3000 KK	72000 EK
S.FL.K.CW	4928081			500 BL	3000 KK	72000 EK
S.FL.K.F1	4935041			500 BL	3000 KK	24000 EK
S.FL.K.F9	2846544			500 BL	3000 KK	72000 EK

WS = white, BR = brown, SL = silver, EV1 = anodised silver, F1 = silver colour, F3 = gold colour, BZ-RB = bronze red brown, F9 = titanium coloured, CW = creme white

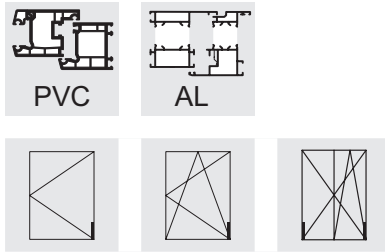

Sash hinge FWV 20-13

- For use in combination with corner hinges ESV..., ESVW... and EL.HW...
- Rebate hinge version
- Height adjustment ± 3 mm
- Automatic and manual assembly possible

Sash hinge cover FLK FWV

- Plastic cover for the visible sash hinge roll
- Available in different colours

Sash hinge plug FLS FWV

- PVC plug to protect the adjusting screw
- Available in different colours
- Non-handed

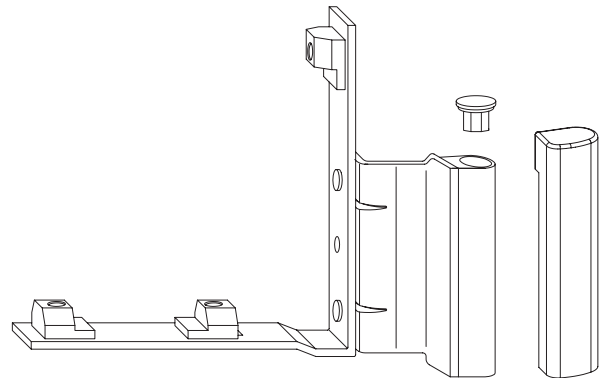

Item description	Item No.		Max. sash weight (kg)	Overlap	Groove centre position	VPA1 Qty./Type	VPA2 Qty./Type	VPA3 Qty./Type
FWV 20-13 LS SL	1945225	4	130	20	13	100 KK	800 EK	
FWV 20-13 RS SL	1945188	4	130	20	13	100 KK	800 EK	
FWV 20-13 LS SL/WS	1934850	4	130	20	13	100 KK	800 EK	
FWV 20-13 RS SL/WS	1935035	4	130	20	13	100 KK	800 EK	
FWV 20-13 LS SL/BR	1934809	4	130	20	13	100 KK	800 EK	
FWV 20-13 RS SL/BR	1934956	4	130	20	13	100 KK	800 EK	
FWV 20-13 LS SL/CW	4935834	4	130	20	13	100 KK	800 EK	
FWV 20-13 RS SL/CW	4935833	4	130	20	13	100 KK	800 EK	
FWV 20-13 LS SL/F9	4978702	4	130	20	13	100 KK	800 EK	
FWV 20-13 RS SL/F9	4978701	4	130	20	13	100 KK	800 EK	
FLK FWV LS WS	2301624					100 BL	300 KK	2400 EK
FLK FWV RS WS	2301616					100 BL	300 KK	2400 EK
FLK FWV LS BR	2301608					100 BL	300 KK	2400 EK
FLK FWV RS BR	2301595					100 BL	300 KK	2400 EK
FLK FWV LS F1	2394154					100 BL	300 KK	2400 EK
FLK FWV RS F1	2394162					100 BL	300 KK	2400 EK
FLK FWV LS F3	4995003					100 BL	300 KK	2400 EK
FLK FWV RS F3	4995001					100 BL	300 KK	2400 EK
FLK FWV LS F9	2854798					100 BL	300 KK	2400 EK
FLK FWV RS F9	2854801					100 BL	300 KK	2400 EK
FLK FWV LS BZ-AM	4984413					100 BL	300 KK	2400 EK
FLK FWV RS BZ-AM	4984414					100 BL	300 KK	2400 EK
FLK FWV LS CW	4997445					100 BL	300 KK	2400 EK
FLK FWV RS CW	4997441					100 BL	300 KK	2400 EK
FLK FWV LS SW	1260457					100 BL	300 KK	2400 EK
FLK FWV RS SW	1260458					100 BL	300 KK	2400 EK
FLK FWV LS F1-ELOX.	5021129					100 BL	300 K3	2400 E3
FLK FWV RS F1-ELOX.	5021130					100 BL	300 K3	2400 E3
FLS FWV SL	1993420					500 BL	5000 KK	40000 EK
FLS FWV WS	1521617					500 BL	5000 KK	40000 EK
FLS FWV BR	1521625					500 BL	5000 KK	40000 EK
FLS FWV F9	2854819					500 BL	5000 KK	40000 EK

RS = right, LS = left

AGR = anthracite grey, BR = brown, BZ-AM = bronze - antique brass, BZ-RB = bronze - red brown, BZ-CU = bronze coppery, CW = creme white, EV1 = anodised silver, F1 = silver colour, F1-elox = sim. to F1 anodised silver, F3 = gold colour, F3-MG = gold mat, F9 = titanium coloured, LBR = clay brown, PW = pearl white, SG = silver grey, SGB = grey, SGR = dusty grey, SL = silver look (zinc galvanised), SW = jet black, WS = white

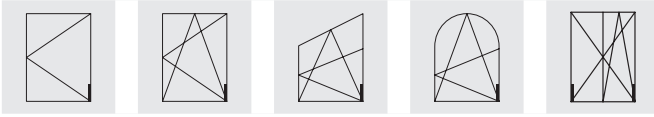
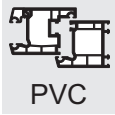

Sash hinge FK-F

6

- Used in combination with corner hinges ESV... or ESVW...
- Can be used left and right hand
- Height adjustment ± 3 mm
- Sash weight max. 100 kg
- Load bearing parts are made of steel
- Integrated friction turn control

Accessories: Sash hinge covers FLK FK-F

- Can be used left and right hand

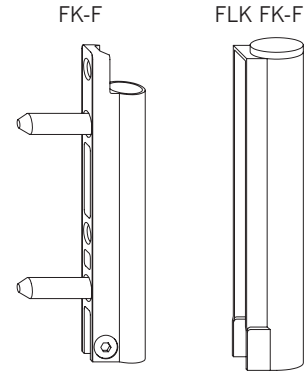

Sash hinge with adjustment screw for regulating the friction turn control

Item description	Item No.		Max. sash weight (kg)	VPA1 Qty./Type	VPA2 Qty./Type	VPA3 Qty./Type
FK-F 20-6/20 SL	1898617	2	100	250 KK	2000 EK	
FK-F 20-6/20 BR	1568909	2	100	250 KK	2000 EK	
FK-F 20-6/20 CW	2548731	2	100	250 KK	2000 EK	
FK-F 20-6/20 F9	2010421	2	100	250 KK	2000 EK	
FK-F 20-6/20 WS	1568896	2	100	250 KK	2000 EK	
FK-F 20-6-28 WS	1557943	2	100	250 KK	2000 EK	
FK-F 20-6-28/20 SL	2588830	2	100	250 KK	6000 EK	
FK-F 20-6-28/20 SL/F9	4949436	2	100	250 KK	6000 EK	
FLK FK-F 20-6/20 WS	1536448			100 BL	300 KK	7200 EK
FLK FK-F 20-6/20 BR	1536456			100 BL	300 KK	7200 EK
FLK FK-F 20-6/20 BZ-AM	4984412			100 BL	300 KK	7200 EK
FLK FK-F 20-6/20 F1	2201906			100 BL	300 KK	2400 EK
FLK FK-F 20-6/20 F3	4995034			100 BL	300 KK	2400 EK
FLK FK-F 20-6/20 F9	2548248			100 BL	300 KK	2400 EK
FLK FK-F 20-6-20 CW	4965802			100 BL	300 KK	2400 EK
FLK FK-F 20-6-20 SW	4930264			100 BL	300 KK	2400 EK

AGR = anthracite grey, BR = brown, BZ-AM = bronze - antique brass, BZ-RB = bronze - red brown, BZ-CU = bronze coppery, CW = creme white, EV1 = anodised silver, F1 = silver colour, F1-elox = sim. to F1 anodised silver, F3 = gold colour, F3-MG = gold mat, F9 = titanium coloured, LBR = clay brown, PW = pearl white, SG = silver grey, SGB = grey, SGR = dusty grey, SL = silver look (zinc galvanised), SW = jet black, WS = white

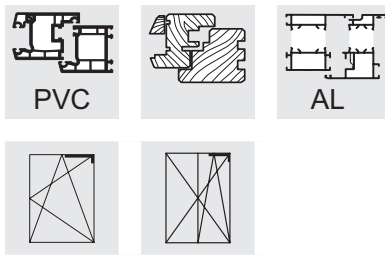

Shears SK ... 18-9

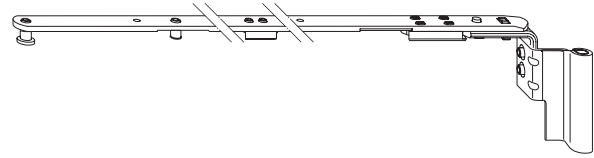

- For 18 mm overlap and 9 mm eurogroove position
- Used in combination with shear hinges SL.KS, SL.KB or SL.HW
- Only two shear sizes
- Adjustment for lifting and lowering the sash (+3.5/-2.0 mm)
- Tilt opening width approx. 135 to 140 mm (depending on profile)
- Use tilt limiter KBG.OS for sash rebate heights ≤ 600 mm
- Sash weight max. 130 kg
- Shear with tandem action
- After assembly the top rod and the shear are firmly attached to one another
- Integrated turn restriction via plastic sleeve in shear hinge
- Visible parts available in various colours



Shear hinge cap K.SK

- Plastic cover for the shear hinge
- Can be used left and right hand
- See shear hinge SL.KS, SL.KB, SL.HW

Item description	Item No.	Overlap	Groove centre position	VPA1 Qty./Type	VPA2 Qty./Type	VPA3 Qty./Type
SK1.18-9.LS	4986901	18	9	10 BD	60 KK	480 EK
SK1.18-9.RS	4986900	18	9	10 BD	60 KK	480 EK
SK1.18-9.LS.WS	4998660	18	9	10 BD	60 KK	480 EK
SK1.18-9.RS.WS	4998659	18	9	10 BD	60 KK	480 EK
SK1.18-9.LS.F9	4998662	18	9	10 BD	60 KK	480 EK
SK1.18-9.RS.F9	4998661	18	9	10 BD	60 KK	480 EK
SK2.18-9.LS	4986903	18	9	10 BD	80 GK	960 EK
SK2.18-9.RS	4986902	18	9	10 BD	80 GK	960 EK
SK2.18-9.LS.WS	4998700	18	9	10 BD	80 GK	960 EK
SK2.18-9.RS.WS	4998669	18	9	10 BD	80 GK	960 EK
SK2.18-9.LS.F9	4998702	18	9	10 BD	80 GK	960 EK
SK2.18-9.RS.F9	4998701	18	9	10 BD	80 GK	960 EK

RS = right, LS = left
WS = white, F9 = titanium coloured

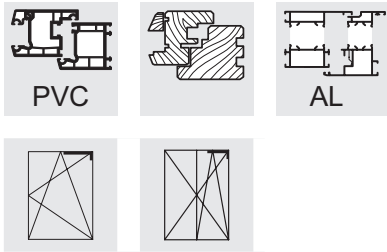

Shears SK ... 20-9

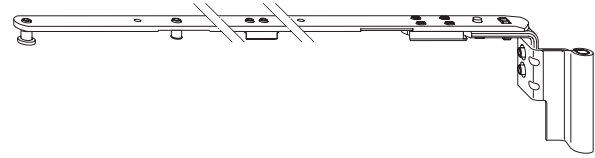

7

- For 20 mm overlap and 9 mm groove centre position
- Used in combination with shear hinges SL.KS, SL.KB or SL.HW
- Only two shear sizes
- Adjustment for lifting and lowering the sash (+3.5/-2.0 mm)
- Tilt opening width approx. 135 to 140 mm (depending on profile)
- Use tilt limiter KBG.OS for sash rebate heights ≤ 600 mm
- Sash weight max. 130 kg
- Shear with tandem action
- After assembly the top rod and the shear are firmly attached to one another
- Integrated turn restriction via plastic sleeve in shear hinge
- Visible parts available in various colours



Shear hinge cap K.SK

- Plastic cover for the shear hinge
- Can be used left and right hand
- See shear hinge SL.KS, SL.KB, SL.HW

Item description	Item No.	Overlap	Groove centre position	VPA1 Qty./Type	VPA2 Qty./Type	VPA3 Qty./Type
SK1.20-9.LS	4926345	20	9	10 BD	60 KK	480 EK
SK1.20-9.RS	4926344	20	9	10 BD	60 KK	480 EK
SK1.20-9.LS.WS	4926348	20	9	10 BD	60 KK	480 EK
SK1.20-9.RS.WS	4926346	20	9	10 BD	60 KK	480 EK
SK1.20-9.LS.F9	4926380	20	9	10 BD	60 KK	480 EK
SK1.20-9.RS.F9	4926349	20	9	10 BD	60 KK	480 EK
SK2.20-9.LS	4926384	20	9	10 BD	80 GK	960 EK
SK2.20-9.RS	4926383	20	9	10 BD	80 GK	960 EK
SK2.20-9.LS.WS	4926386	20	9	10 BD	80 GK	960 EK
SK2.20-9.RS.WS	4926385	20	9	10 BD	80 GK	960 EK
SK2.20-9.LS.F9	4926388	20	9	10 BD	80 GK	960 EK
SK2.20-9.RS.F9	4926387	20	9	10 BD	80 GK	960 EK

RS = right, LS = left
 WS = white, BR = brown, SL = silver, F1 = silver coloured, F3 = gold coloured, F9 = titanium coloured

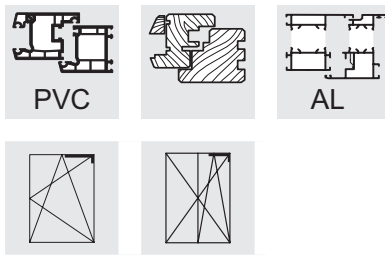

Shears SK ... 18-13

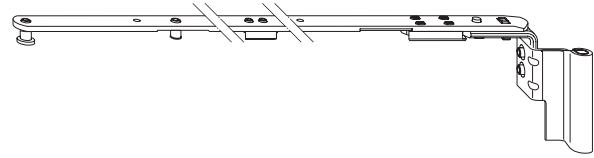

- For 18 mm overlap and 13 mm groove centre position
- Used in combination with shear hinges
SL.KS, SL.KB or SL.HW
- Only two shear sizes
- Adjustment for lifting and lowering the sash
(+3.5/-2.0 mm)
- Tilt opening width approx. 135 to 140 mm
(depending on profile)
- Use tilt limiter KBG.OS for sash rebate heights ≤ 600 mm
- Sash weight max. 130 kg
- Shear with tandem action
- After assembly the top rod and the shear are firmly attached to one another
- Integrated turn restriction via plastic sleeve in shear hinge
- Visible parts available in various colours

7



Shear hinge cap K.SK

- Plastic cover for the shear hinge
- Can be used left and right hand
- See shear hinge SL.KS, SL.KB, SL.HW

Item description	Item No.	Overlap	Groove centre position	VPA1 Qty./Type	VPA2 Qty./Type	VPA3 Qty./Type
SK1.18-13.LS	4998664	18	13	10 BD	60 KK	480 EK
SK1.18-13.RS	4998663	18	13	10 BD	60 KK	480 EK
SK1.18-13.LS.WS	4998666	18	13	10 BD	60 KK	480 EK
SK1.18-13.RS.WS	4998665	18	13	10 BD	60 KK	480 EK
SK1.18-13.LS.F9	4998668	18	13	10 BD	60 KK	480 EK
SK1.18-13.RS.F9	4998667	18	13	10 BD	60 KK	480 EK
SK2.18-13.LS	4998704	18	13	10 BD	80 GK	960 EK
SK2.18-13.RS	4998703	18	13	10 BD	80 GK	960 EK
SK2.18-13.LS.WS	4998706	18	13	10 BD	80 GK	960 EK
SK2.18-13.RS.WS	4998705	18	13	10 BD	80 GK	960 EK
SK2.18-13.LS.F9	4998708	18	13	10 BD	80 GK	960 EK
SK2.18-13.RS.F9	4998707	18	13	10 BD	80 GK	960 EK

RS = right, LS = left

WS = white, BR = brown, SL = silver, F1 = silver coloured, F3 = gold coloured, F9 = titanium coloured

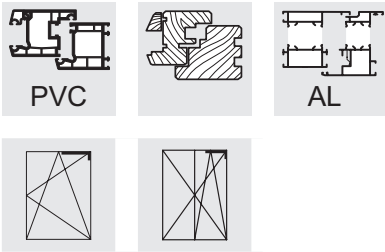

Shears SK ... 20-13

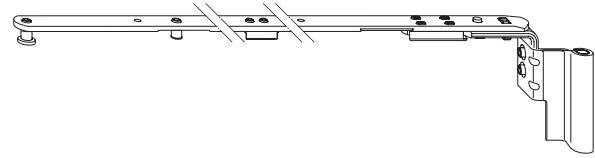

7

- For 20 mm overlap and 13 mm groove centre position
- Used in combination with shear hinges SL.KS, SL.KB or SL.HW
- Only two shear sizes
- Adjustment for lifting and lowering the sash (+3.5/-2.0 mm)
- Tilt opening width approx. 135 to 140 mm (depending on profile)
- Use tilt limiter KBG.OS for sash rebate heights ≤ 600 mm
- Sash weight max. 130 kg
- Shear with tandem action
- After assembly the top rod and the shear are firmly attached to one another
- Integrated turn restriction via plastic sleeve in shear hinge- Visible parts available in various colours



Shear hinge cap K.SK

- Plastic cover for the shear hinge
- Can be used left and right hand
- See shear hinge SL.KS, SL.KB, SL.HW

Item description	Item No.	Overlap	Groove centre position	VPA1 Qty./Type	VPA2 Qty./Type	VPA3 Qty./Type
SK1.20-13.LS	2844101	20	13	10 BD	60 KK	480 EK
SK1.20-13.RS	2842578	20	13	10 BD	60 KK	480 EK
SK1.20-13.RS.WS	2858289	20	13	10 BD	60 KK	480 EK
SK1.20-13.LS.WS	2858406	20	13	10 BD	60 KK	480 EK
SK1.20-13.RS.F9	2858449	20	13	10 BD	60 KK	480 EK
SK1.20-13.LS.F9	2858481	20	13	10 BD	60 KK	480 EK
SK1.20-13.LS.BR	4926392	20	13	10 BD	60 KK	480 EK
SK1.20-13.RS.BR	4926391	20	13	10 BD	60 KK	480 EK
SK1.20-13.LS.CW	4928072	20	13	10 BD	60 KK	480 EK
SK1.20-13.RS.CW	4928071	20	13	10 BD	60 KK	480 EK
SK2.20-13.RS	2842586	20	13	10 BD	80 GK	960 EK
SK2.20-13.LS	2844143	20	13	10 BD	80 GK	960 EK
SK2.20-13.RS.WS	2858684	20	13	10 BD	80 GK	960 EK
SK2.20-13.LS.WS	2858730	20	13	10 BD	80 GK	960 EK
SK2.20-13.RS.F9	2858781	20	13	10 BD	80 GK	960 EK
SK2.20-13.LS.F9	2858810	20	13	10 BD	80 GK	960 EK
SK2.20-13.LS.BR	4926394	20	13	10 BD	80 GK	960 EK
SK2.20-13.RS.BR	4926393	20	13	10 BD	80 GK	960 EK
SK2.20-13.LS.CW	4928074	20	13	10 BD	80 GK	960 EK
SK2.20-13.RS.CW	4928073	20	13	10 BD	80 GK	960 EK

RS = right, LS = left

AGR = anthracite grey, BR = brown, BZ-AM = bronze - antique brass, BZ-RB = bronze - red brown, BZ-CU = bronze coppery, CW = creme white, EV1 = anodised silver, F1 = silver colour, F1-elox = sim. to F1 anodised silver, F3 = gold colour, F3-MG = gold mat, F9 = titanium coloured, LBR = clay brown, PW = pearl white, SG = silver grey, SGB = grey, SGR = dusty grey, SL = silver look (zinc galvanised), SW = jet black, WS = white

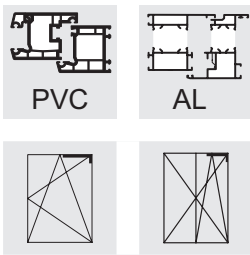

Shears SK ... 21-13

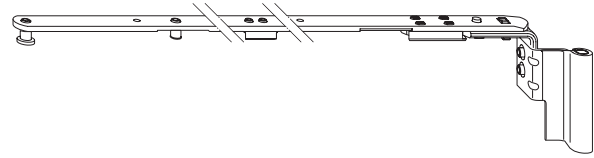

- For 21 mm overlap and 13 mm groove centre position
- Only two shear sizes
- Adjustment for lifting and lowering the sash (+3.5/-2.0 mm)
- Tilt opening width approx. 135 to 140 mm (depending on profile)
- Use tilt limiter KBG.OS for sash rebate heights ≤ 600 mm
- Sash weight max. 130 kg
- Shear with tandem action
- After assembly the top rod and the shear are firmly attached to one another
- Integrated turn restriction via plastic sleeve in shear hinge
- Visible parts available in various colours

Shear hinge cap K.SK

- Plastic cover for the shear hinge
- Can be used left and right hand
- See shear hinge SL.KS, SL.KB, SL.HW



Item description	Item No.	Overlap	Groove centre position	VPA1 Qty./Type	VPA2 Qty./Type	VPA3 Qty./Type
SK1.21-13.LS	4926397	21	13	10 BD	60 KK	480 EK
SK1.21-13.RS	4926396	21	13	10 BD	60 KK	480 EK
SK1.21-13.LS.WS	4926399	21	13	10 BD	60 KK	480 EK
SK1.21-13.RS.WS	4926398	21	13	10 BD	60 KK	480 EK
SK1.21-13.LS.BR	4926403	21	13	10 BD	60 KK	480 EK
SK1.21-13.RS.BR	4926402	21	13	10 BD	60 KK	480 EK
SK1.21-13.LS.CW	4928076	21	13	10 BD	60 KK	480 EK
SK1.21-13.RS.CW	4928075	21	13	10 BD	60 KK	480 EK
SK1.21-13.LS.F9	4926401	21	13	10 BD	60 KK	480 EK
SK1.21-13.RS.F9	4926400	21	13	10 BD	60 KK	480 EK
SK2.21-13.LS	4926405	21	13	10 BD	80 GK	960 EK
SK2.21-13.RS	4926404	21	13	10 BD	80 GK	960 EK
SK2.21-13.LS.WS	4926407	21	13	10 BD	80 GK	960 EK
SK2.21-13.RS.WS	4926406	21	13	10 BD	80 GK	960 EK
SK2.21-13.LS.BR	4926411	21	13	10 BD	80 GK	960 EK
SK2.21-13.RS.BR	4926410	21	13	10 BD	80 GK	960 EK
SK2.21-13.LS.CW	4928078	21	13	10 BD	80 GK	960 EK
SK2.21-13.RS.CW	4928077	21	13	10 BD	80 GK	960 EK
SK2.21-13.LS.F9	4926409	21	13	10 BD	80 GK	960 EK
SK2.21-13.RS.F9	4926408	21	13	10 BD	80 GK	960 EK

RS = right, LS = left

WS = white, BR = brown, SL = silver, EV1 = anodised silver, F1 = silver colour, F3 = gold colour, BZ-RB = bronze red brown, F9 = titanium coloured, CW = creme white

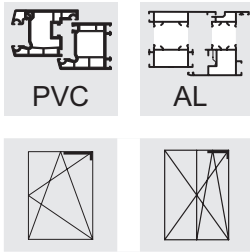

Shears SK ... 22-13

- For 22 mm overlap and 13 mm groove position
- Only two shear sizes
- Adjustment for lifting and lowering the sash (+3.5/-2.0 mm)
- Tilt opening width approx. 135 to 140 mm (depending on profile)
- Use tilt limiter KBG.OS for sash rebate heights ≤ 600 mm
- Sash weight max. 130 kg
- Shear with tandem action
- After assembly the top rod and the shear are firmly attached to one another
- Integrated turn restriction via plastic sleeve in shear hinge
- Visible parts available in various colours

Shear hinge cap K.SK

- Plastic cover for the shear hinge
- Can be used left and right hand
- See shear hinge SL.KS, SL.KB, SL.HW

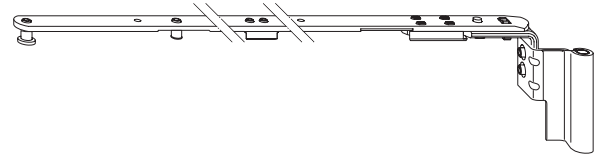

7

Item description	Item No.	Overlap	Groove centre position	VPA1 Qty./Type	VPA2 Qty./Type	VPA3 Qty./Type
SK1.22-13.LS	4935763	22	13	10 BD	60 KK	480 EK
SK1.22-13.RS	4935762	22	13	10 BD	60 KK	480 EK
SK2.22-13.LS	4935767	22	13	10 BD	80 GK	960 EK
SK2.22-13.RS	4935766	22	13	10 BD	80 GK	960 EK

RS = right, LS = left

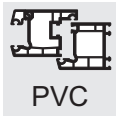

PVC

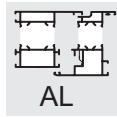

AL

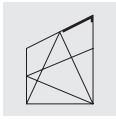

Shears SK ... A.18-9

- For 18 mm overlap and 9 mm eurogroove position
- Used in combination with shear hinges SL.KS, SL.KB or SL.HW
- For non square edges in the shear area
- Adjustable angle setting
- Only two shear sizes
- Adjustment for lifting and lowering the sash (+3.5/-2.0 mm)
- Max. sash weight 80 kg
- After assembly the top rod and the shear are firmly attached to one another
- Integrated turn restriction via plastic sleeve in shear hinge
- Visible parts available in various colours

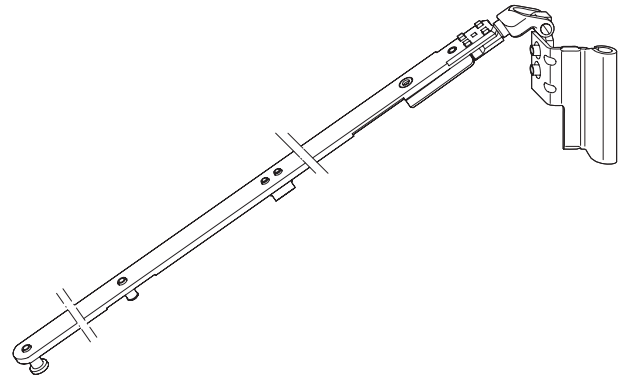

7

Shear hinge cap K.SK

- Plastic cover for the shear hinge
- Can be used left and right hand
- See shear hinge SL.KS, SL.KB, SL.HW



Item description	Item No.	Overlap	Groove centre position	VPA1 Qty./Type	VPA2 Qty./Type	VPA3 Qty./Type
SK1.A.18-9.LS	4998720	18	9	10 BD	60 KK	480 EK
SK1.A.18-9.RS	4998709	18	9	10 BD	60 KK	480 EK
SK2.A.18-9.LS	4998742	18	9	10 BD	80 GK	320 EK
SK2.A.18-9.RS	4998741	18	9	10 BD	80 GK	320 EK

RS = right, LS = left

WS = white, BR = brown, SL = silver, F1 = silver coloured, F3 = gold coloured, F9 = titanium coloured

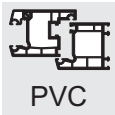

PVC

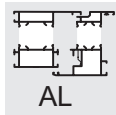

AL



Shears SK ... A.20-9

- For 20 mm overlap and 9 mm groove centre position
- Used in combination with shear hinges SL.KS, SL.KB or SL.HW
- For non square edges in the shear area
- Adjustable angle setting
- Only two shear sizes
- Adjustment for lifting and lowering the sash (+3.5/-2.0 mm)
- Max. sash weight 80 kg
- After assembly the top rod and the shear are firmly attached to one another
- Integrated turn restriction via plastic sleeve in shear hinge
- Visible parts available in various colours

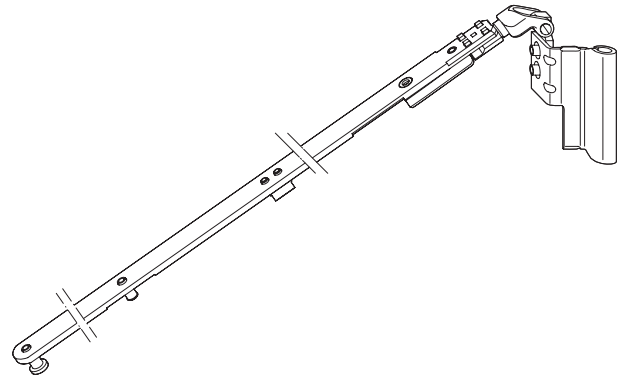

7

Shear hinge cap K.SK

- Plastic cover for the shear hinge
- Can be used left and right hand
- See shear hinge SL.KS, SL.KB, SL.HW



Item description	Item No.	Overlap	Groove centre position	VPA1 Qty./Type	VPA2 Qty./Type	VPA3 Qty./Type
SK1.A.20-9.LS	4926615	20	9	10 BD	60 KK	480 EK
SK1.A.20-9.RS	4926613	20	9	10 BD	60 KK	480 EK
SK2.A.20-9.LS	4926651	20	9	10 BD	80 GK	320 EK
SK2.A.20-9.RS	4926650	20	9	10 BD	80 GK	320 EK

RS = right, LS = left

WS = white, BR = brown, SL = silver, F1 = silver coloured, F3 = gold coloured, F9 = titanium coloured

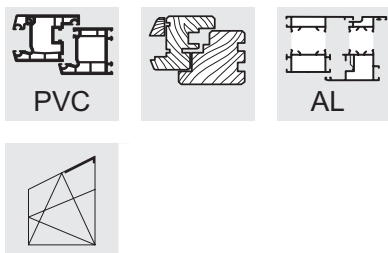

Shears SK ... A.18-13

- For 18 mm overlap and 13 mm groove centre position
- Used in combination with shear hinges SL.KS, SL.KB or SL.HW
- For non square edges in the shear area
- Adjustable angle setting
- Only two shear sizes
- Adjustment for lifting and lowering the sash (+3.5/-2.0 mm)
- Max. sash weight 80 kg
- After assembly the top rod and the shear are firmly attached to one another
- Integrated turn restriction via plastic sleeve in shear hinge
- Visible parts available in various colours

Shear hinge cap K.SK

- Plastic cover for the shear hinge
- Can be used left and right hand
- See shear hinge SL.KS, SL.KB, SL.HW

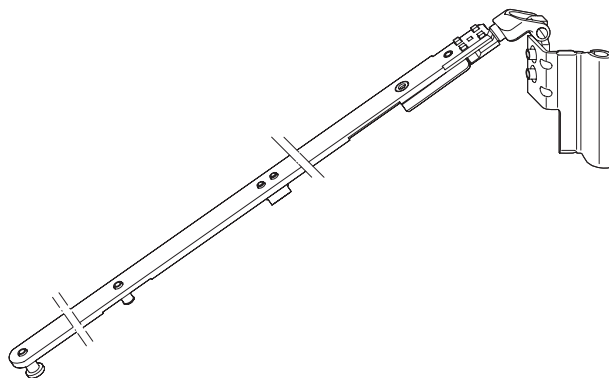

7

Item description	Item No.	Overlap	Groove centre position	VPA1 Qty./Type	VPA2 Qty./Type	VPA3 Qty./Type
SK1.A.18-13.LS	4998726	18	13	10 BD	60 KK	480 EK
SK1.A.18-13.RS	4998725	18	13	10 BD	60 KK	480 EK
SK2.A.18-13.LS	4998748	18	13	10 BD	80 GK	320 EK
SK2.A.18-13.RS	4998747	18	13	10 BD	80 GK	320 EK

RS = right, LS = left

WS = white, BR = brown, SL = silver, F1 = silver coloured, F3 = gold coloured, F9 = titanium coloured

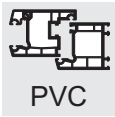

PVC

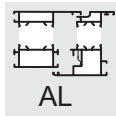

AL

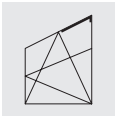

Shears SK ... A.20-13

- For 20 mm overlap and 13 mm groove centre position
- Used in combination with shear hinges SL.KS, SL.KB or SL.HW
- For non square edges in the shear area
- Adjustable angle setting
- Only two shear sizes
- Adjustment for lifting and lowering the sash (+3.5/-2.0 mm)
- Max. sash weight 80 kg
- After assembly the top rod and the shear are firmly attached to one another
- Integrated turn restriction via plastic sleeve in shear hinge
- Visible parts available in various colours

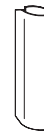
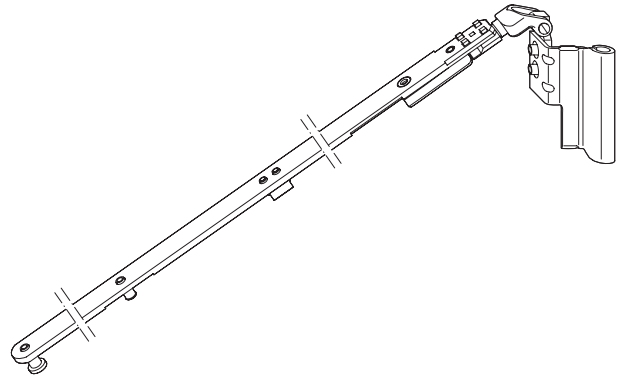

Shear hinge cap K.SK

- Plastic cover for the shear hinge
- Can be used left and right hand
- See shear hinge SL.KS, SL.KB, SL.HW

Item description	Item No.	Overlap	Groove centre position	VPA1 Qty./Type	VPA2 Qty./Type	VPA3 Qty./Type
SK1.A.20-13.LS	4926634	20	13	10 BD	60 KK	480 EK
SK1.A.20-13.RS	4926631	20	13	10 BD	60 KK	480 EK
SK1.A.20-13.LS.WS	4926636	20	13	10 BD	60 KK	480 EK
SK1.A.20-13.RS.WS	4926635	20	13	10 BD	60 KK	480 EK
SK1.A.20-13.LS.F9	4926642	20	13	10 BD	60 KK	480 EK
SK1.A.20-13.RS.F9	4926637	20	13	10 BD	60 KK	480 EK
SK2.A.20-13.LS	4926659	20	13	10 BD	80 GK	320 EK
SK2.A.20-13.RS	4926658	20	13	10 BD	80 GK	320 EK
SK2.A.20-13.LS.WS	4926672	20	13	10 BD	80 GK	320 EK
SK2.A.20-13.RS.WS	4926670	20	13	10 BD	80 GK	320 EK
SK2.A.20-13.LS.F9	4926674	20	13	10 BD	80 GK	320 EK
SK2.A.20-13.RS.F9	4926673	20	13	10 BD	80 GK	320 EK

RS = right, LS = left

WS = white, BR = brown, SL = silver, F1 = silver coloured, F3 = gold coloured, F9 = titanium coloured

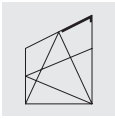
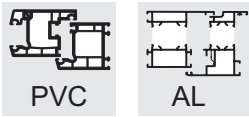

Shears SK ... A.21-13

- For 21 mm overlap and 13 mm groove centre position
- Only two shear sizes
- Adjustment for lifting and lowering the sash (+3.5/-2.0 mm)
- Angle hinge shear for PVC-U windows
- Max. sash weight 80 kg
- After assembly the top rod and the shear are firmly attached to one another
- Integrated turn restriction via plastic sleeve in shear hinge
- Adjustable angle setting
- Visible parts available in various colours
- For non square edges in the shear area

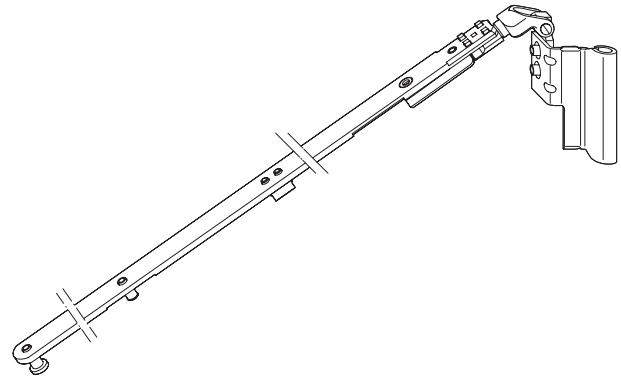

7

Shear hinge cap K.SK

- Plastic cover for the shear hinge
- Can be used left and right hand
- See shear hinge SL.KS, SL.KB, SL.HW



Item description	Item No.	Overlap	Groove centre position	VPA1 Qty./Type	VPA2 Qty./Type	VPA3 Qty./Type
SK1.A.21-13.LS	4926678	21	13	10 BD	60 KK	480 EK
SK1.A.21-13.RS	4926677	21	13	10 BD	60 KK	480 EK
SK2.A.21-13.LS	4926686	21	13	10 BD	80 GK	320 EK
SK2.A.21-13.RS	4926685	21	13	10 BD	80 GK	320 EK
SK2.A.21-13.LS.WS	4926688	21	13	10 BD	80 GK	320 EK
SK2.A.21-13.RS.WS	4926687	21	13	10 BD	80 GK	320 EK

RS = right, LS = left

WS = white, BR = brown, SL = silver, F1 = silver coloured, F3 = gold coloured, F9 = titanium coloured

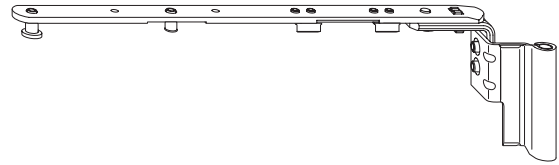
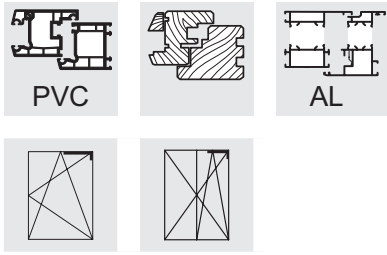

Shears SK ... E...

- Useable for 9 mm and 13 mm groove centre position
- Used in combination with shear hinges
SL.KS, SL.KB or SL.HW
- For the type of fitting "Tilt before turn"
- Only two shear sizes
- Adjustment for lifting and lowering the sash
(+3.5/-2.0 mm)
- Tilt opening width approx. 135 to 140 mm
(depending on profile)
- Use tilt limiter KBG.OS for sash rebate heights ≤ 600 mm
- In combination with top rod OS. E
- Sash weight max. 130 kg
- Shear with tandem action
- After assembly the top rod and the shear are firmly attached to one another
- Integrated turn restriction via plastic sleeve in shear hinge
- Visible parts available in various colours

Shear hinge cap K.SK

- Plastic cover for the shear hinge
- Can be used left and right hand
- See shear hinge SL.KS, SL.KB, SL.HW

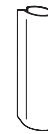

Item description	Item No.	Overlap	Groove centre position	VPA1 Qty./Type	VPA2 Qty./Type	VPA3 Qty./Type
SK1.E.18-13.LS	5012366	18	13	10 BD	60 KK	480 EK
SK1.E.18-13.RS	5012365	18	13	10 BD	60 KK	480 EK
SK1.E.20-9.LS	4926183	20	9	10 BD	60 KK	480 EK
SK1.E.20-9.RS	4926182	20	9	10 BD	60 KK	480 EK
SK1.E.20-9.LS.WS	4926162	20	9	10 BD	60 KK	480 EK
SK1.E.20-9.RS.WS	4926161	20	9	10 BD	60 KK	480 EK
SK1.E.20-13.LS	4926185	20	13	10 BD	60 KK	480 EK
SK1.E.20-13.RS	4926184	20	13	10 BD	60 KK	480 EK
SK1.E.20-13.LS.WS	4926164	20	13	10 BD	60 KK	480 EK
SK1.E.20-13.RS.WS	4926163	20	13	10 BD	60 KK	480 EK
SK1.E.20-13.RS.F9	4969036	20	13	10 BD	60 KK	480 EK
SK1.E.20-13.LS.F9	4969037	20	13	10 BD	60 KK	480 EK
SK2.E.18-13.LS	5012368	18	13	10 BD	80 GK	320 EK
SK2.E.18-13.RS	5012367	18	13	10 BD	80 GK	320 EK
SK2.E.20-9.LS	4926167	20	9	10 BD	80 GK	960 EK
SK2.E.20-9.RS	4926166	20	9	10 BD	80 GK	960 EK
SK2.E.20-13.LS	4926169	20	13	10 BD	80 GK	960 EK
SK2.E.20-13.RS	4926168	20	13	10 BD	80 GK	960 EK
SK2.E.20-13.LS.WS	4926193	20	13	10 BD	80 GK	960 EK
SK2.E.20-13.RS.WS	4926192	20	13	10 BD	80 GK	960 EK
SK2.E.20-13.RS.F9	4969038	20	13	10 BD	80 GK	960 EK
SK2.E.20-13.LS.F9	4969039	20	13	10 BD	80 GK	960 EK

RS = right, LS = left
 WS = white, BR = brown, SL = silver, F1 = silver coloured, F3 = gold coloured, F9 = titanium coloured

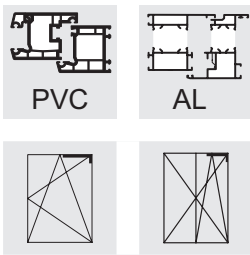

Shears SK ... E.21-13

- For 21 mm overlap and 13 mm groove centre position
- For the type of fitting "Tilt before turn"
- Only two shear sizes
- Adjustment for lifting and lowering the sash (+3.5/-2.0 mm)
- Tilt opening width approx. 135 to 140 mm (depending on profile)
- Use tilt limiter KBG.OS for sash rebate heights ≤ 600 mm
- In combination with top rod OS. E
- Shear with tandem action
- After assembly the top rod and the shear are firmly attached to one another
- Integrated turn restriction via plastic sleeve in shear hinge
- Visible parts available in various colours
- Sash weight max. 130 kg

Shear hinge cap K.SK

- Plastic cover for the shear hinge
- Can be used left and right hand
- See shear hinge SL.KS, SL.KB, SL.HW

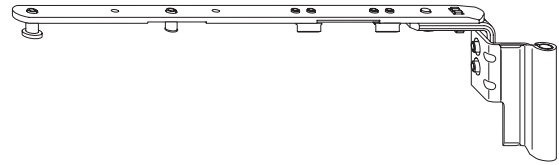

Item description	Item No.	Overlap	Groove centre position	VPA1 Qty./Type	VPA2 Qty./Type	VPA3 Qty./Type
SK1.E.21-13.LS	4969578	21	13	10 BD	60 KK	480 EK
SK1.E.21-13.RS	4969656	21	13	10 BD	60 KK	480 EK
SK2.E.21-13.LS	4969674	21	13	10 BD	80 GK	960 EK
SK2.E.21-13.RS	4969679	21	13	10 BD	80 GK	960 EK

RS = right, LS = left
 WS = white, BR = brown, SL = silver, F1 = silver coloured, F3 = gold coloured, F9 = titanium coloured

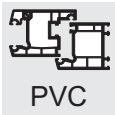

PVC

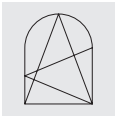

Round arch set GRT.RB.K.A

- For round-arch windows
- Only one shear size
- Integrated lifter for lifting the sash in tilt position
- Max. sash weight 80 kg
- In combination with GRT.RB.K.SB

7

Round arch set GRT.RB.K.A consisting of:

- Shear GR1.SL
- Connecting rail AARB 1000-3
- Accessories kit round-arch windows

Round arch accessories kit consisting of:

- Dual function element DFE
- Frame part DFE-TFE
- Limiter K-SEF 1 SC
- Connecting plate RB.SL

Set GRT.RB.K

- Without connecting rail AARB 1000-3

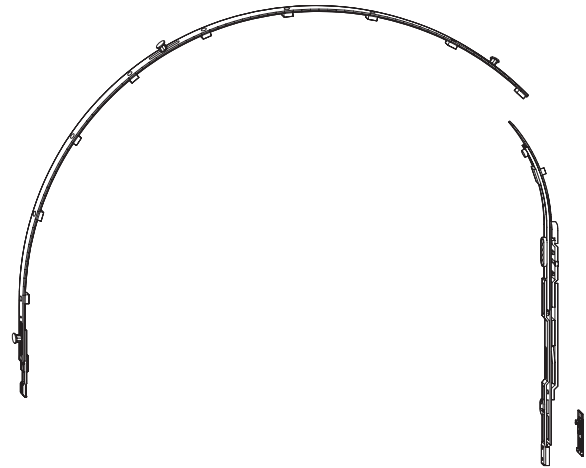

Item description	Item No.	VPA1 Qty./Type	VPA2 Qty./Type
GRT.RB.K.A	4927282	1 KT	60 EA
GRT.RB.K	4927309	10 GK	120 EK

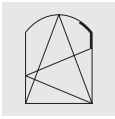
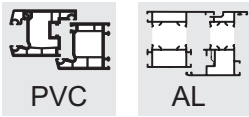

Round arch scissor hinge set GRT.RB.K.SB

- For round-arch windows
- Designed for 12 mm airgap
- Groove centre position 9 mm and 13 mm
- Max. sash weight 80 kg
- Can be used left and right hand
- In combination with round-arch set GRT.RB.K
- Shear hinge cap and shear hinge insert cap in white and brown are included in the scope of delivery.

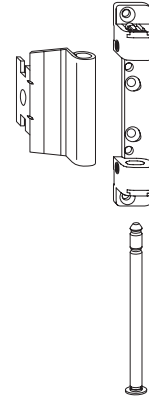

Round-arch shear hinge kit GRT.RB.K.SB ... WS/F9

- As described above, but the shear hinge and shear hinge insert are powdered in the respective colours

7

Item description	Item No.	Scope of application		Overlap	Groove centre position	VPA1 Qty./Type	VPA2 Qty./Type	VPA3 Qty./Type
GRT.RB.K.SB.18-9	4927249	FB	4	18	9	1 BL	50 KK	400 EK
GRT.RB.K.SB.18-13	4927248	FB	4	18	13	1 BL	50 KK	400 EK
GRT.RB.K.SB.20-9.F9	2012419	FB	4	20	9	1 BL	50 KK	400 EK
GRT.RB.K.SB.20-9.WS	1935123	FB	4	20	9	1 BL	50 KK	400 EK
GRT.RB.K.SB.20-13	1898916	FB	4	20	13	1 BL	50 GK	200 EK
GRT.RB.K.SB.20-13.F9	2012099	FB	4	20	13	1 BL	50 KK	400 EK
GRT.RB.K.SB.20-13.WS	1853611	FB	4	20	13	1 BL	50 GK	200 EK
GRT.RB.K.SB.21-13	4927247	FB	4	21	13	1 BL	50 KK	400 EK
GRT.RB.K.SB.22-13	2125940	FB	4	22	13	1 BL	50 KK	400 EK

WS = white, BR = brown, SL = silver, EV1 = anodised silver, F1 = silver colour, F3 = gold colour, BZ-RB = bronze red brown, F9 = titanium coloured, CW = creme white
TB - pot hinge, FB - rebate hinge

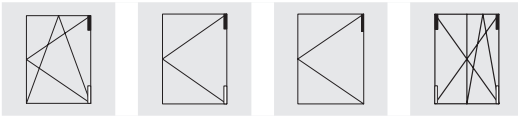
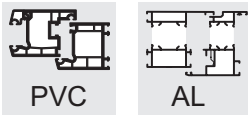

Shear hinge SL.KS

- Shear hinge SL.KS with symmetrical drill holes, corresponding to corner hinge EL.K / ESV
- Patented shear hinge pin protection
- Shear hinge and cover flush with upper edge of sash (for 20 mm sash overlap)
- With anti-twist protection of shear hinge pin
- Shear hinge/corner hinge drilling possible on unwelded profile pieces
- SL.KS shear hinge for sash weights up to 100 kg
- For drill and screw templates, see Group 15, installation drawings B-7-1

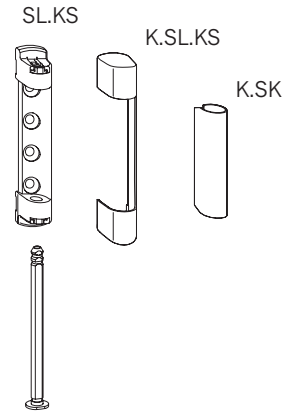

Shear hinge cap K.SL.KS

- Can be used left and right hand

Shear hinge cap K.SK

- Can be used left and right hand

Item description	Item No.		Max. sash weight (kg)	VPA1 Qty./Type	VPA2 Qty./Type	VPA3 Qty./Type
SL.KS.3-3	4926253	4	100	200 KK	1600 EK	
SL.KS.3-3.BR	4938869	4	100	200 KK	1600 EK	
SL.KS.3-3.CW	4938883	4	100	200 KK	1600 EK	
SL.KS.3-3.F9	4938885	4	100	200 KK	1600 EK	
SL.KS.3-3.WS	4928400	4	100	200 KK	4800 EK	
SL.KS.3-6	2844434	4	100	200 KK	1600 EK	
SL.KS.3-6.BR	4927491	4	100	200 KK	1600 EK	
SL.KS.3-6.CW	4928060	4	100	200 KK	1600 EK	
SL.KS.3-6.F9	2844531	4	100	200 KK	1600 EK	
SL.KS.3-6.WS	2844506	4	100	200 KK	1600 EK	
K.SL.KS.WS	2844928			100 BL	300 KK	7200 EK
K.SL.KS.BR	4927420			100 BL	300 KK	7200 EK
K.SL.KS.BZ-RB	4933295			100 BL	300 KK	2400 EK
K.SL.KS.CW	4927558			100 BL	300 KK	2400 EK
K.SL.KS.F1	4928483			100 BL	300 KK	2400 EK
K.SL.KS.F3	4995008			100 BL	300 KK	2400 EK
K.SL.KS.F3-MG	4987448			100 BL	300 KK	2400 EK
K.SL.KS.F9	2845277			100 BL	300 KK	7200 EK
K.SL.KS.LBR	4939020			100 BL	300 KK	2400 EK
K.SL.KS.LGR	5002873			100 BL	300 KK	2400 EK
K.SL.KS.PW	5002872			100 BL	300 KK	2400 EK
K.SL.KS.SW	4939052			100 BL	300 KK	2400 EK
K.SL.KS.F1-ELOX.	5021123			100 BL	300 K3	2400 E3
K.SK.WS	2845285			100 BL	600 KK	14400 EK
K.SK.BR	4927421			100 BL	600 KK	14400 EK
K.SK.BZ-RB	4933296			100 BL	600 KK	4800 EK
K.SK.CW	4927572			100 BL	600 KK	4800 EK
K.SK.F1	4928484			100 BL	600 KK	4800 EK
K.SK.F3	4995009			100 BL	600 KK	4800 EK
K.SK.F3-MG	4987480			100 BL	600 KK	4800 EK
K.SK.F9	2845293			100 BL	600 KK	14400 EK
K.SK.LBR	4939036			100 BL	600 KK	4800 EK
K.SK.SW	4939055			100 BL	600 KK	4800 EK
K.SK.F1-ELOX.	5021124			100 BL	600 K3	4800 E3

AGR = anthracite grey, BR = brown, BZ-AM = bronze - antique brass, BZ-RB = bronze - red brown, BZ-CU = bronze coppery, CW = creme white, EV1 = anodised silver, F1 = silver colour, F1-elox = sim. to F1 anodised silver, F3 = gold colour, F3-MG = gold mat, F9 = titanium coloured, LBR = clay brown, PW = pearl white, SG = silver grey, SGB = grey, SGR = dusty grey, SL = silver look (zinc galvanised), SW = jet black, WS = white

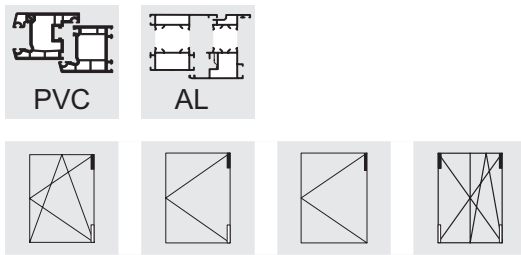

Shear hinge SL.KB

- Patented shear hinge pin protection
- Shear hinge and cover flush with upper edge of sash (for 20 mm sash overlap)
- With anti-twist protection of shear hinge pin
- Shear hinge/corner hinge drilling possible on unwelded profile pieces
- Sash weight max. 130 kg
- For drill and screw templates, see Group 15, installation drawings B-7-1

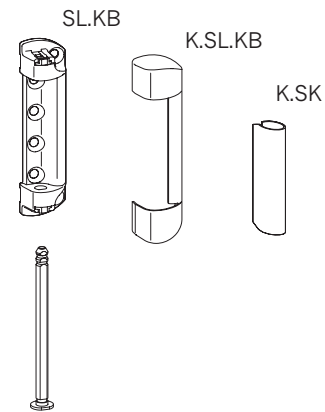

Shear hinge cap K.SL.KB

- Can be used left and right hand

Shear hinge cap K.SK

- Can be used left and right hand

Item description	Item No.		Max. sash weight (kg)	VPA1 Qty./Type	VPA2 Qty./Type	VPA3 Qty./Type
SL.KB.3-6	2901380	6	130	200 KK	1600 EK	
SL.KB.3-6.BR	4927414	6	130	200 KK	1600 EK	
SL.KB.3-6.CW	4928062	6	130	200 KK	1600 EK	
SL.KB.3-6.F9	2901398	6	130	200 KK	1600 EK	
SL.KB.3-6.WS	2901371	6	130	200 KK	1600 EK	
K.SL.KB.WS	2919272			100 BL	300 KK	2400 EK
K.SL.KB.BR	4927427			100 BL	300 KK	2400 EK
K.SL.KB.BZ-RB	4933291			100 BL	300 KK	2400 EK
K.SL.KB.F1	4928481			100 BL	300 KK	2400 EK
K.SL.KB.F3	4995007			100 BL	300 KK	2400 EK
K.SL.KB.F9	2919281			100 BL	300 KK	2400 EK
K.SL.KB.F1-ELOX.	5021128			100 BL	300 K3	2400 E3
K.SK.WS	2845285			100 BL	600 KK	14400 EK
K.SK.BR	4927421			100 BL	600 KK	14400 EK
K.SK.BZ-RB	4933296			100 BL	600 KK	4800 EK
K.SK.CW	4927572			100 BL	600 KK	4800 EK
K.SK.F1	4928484			100 BL	600 KK	4800 EK
K.SK.F3	4995009			100 BL	600 KK	4800 EK
K.SK.F3-MG	4987480			100 BL	600 KK	4800 EK
K.SK.F9	2845293			100 BL	600 KK	14400 EK
K.SK.LBR	4939036			100 BL	600 KK	4800 EK
K.SK.SW	4939055			100 BL	600 KK	4800 EK

AGR = anthracite grey, BR = brown, BZ-AM = bronze - antique brass, BZ-RB = bronze - red brown, BZ-CU = bronze coppery, CW = creme white, EV1 = anodised silver, F1 = silver colour, F1-elox = sim. to F1 anodised silver, F3 = gold colour, F3-MG = gold mat, F9 = titanium coloured, LBR = clay brown, PW = pearl white, SG = silver grey, SGB = grey, SGR = dusty grey, SL = silver look (zinc galvanised), SW = jet black, WS = white

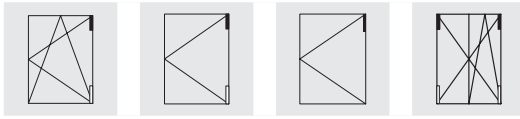
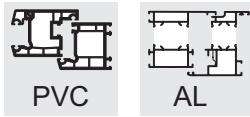

Shear hinge SL.K.3-6.130

- Shear hinge SL.KS with symmetrical drill holes, corresponding to corner hinge EL.K / ESV
- Patented shear hinge pin protection
- Shear hinge and cover flush with upper edge of sash (for 20 mm sash overlap)
- With anti-twist protection of shear hinge pin
- Shear hinge/corner hinge drilling possible on unwelded profile pieces
- Max. sash weight 130 kg (approval on request, subject to profile)
- For drill and screw templates, see Group 15, installation drawings B-7-1

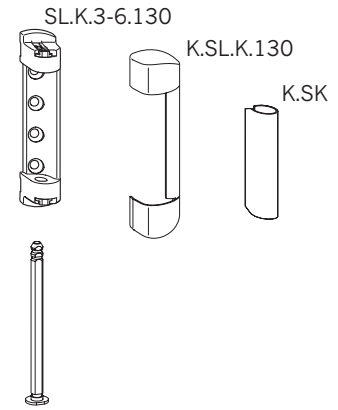

7

Shear hinge cap K.SL.K.130

- Can be used left and right hand

Shear hinge cap K.SK

- Can be used left and right hand

Important for PVC-U windows:

- Screwing of the shear hinge must be performed according to the TBDK guidelines. Adapt the drilling diameter for the fixing screws, the screw diameter and the screw length to the load situation.

Item description	Item No.		Max. sash weight (kg)	VPA1 Qty./Type	VPA2 Qty./Type	VPA3 Qty./Type
SL.K.3-6.130	4987933	4	130	200 KK	1600 EK	
SL.K.3-6.130.BR	4995565	4	130	200 KK	1600 EK	
SL.K.3-6.130.F9	4995564	4	130	200 KK	1600 EK	
SL.K.3-6.130.WS	4995563	4	130	200 KK	1600 EK	
K.SL.K.130.WS	4987952			100 BL	300 KK	2400 EK
K.SL.K.130.BR	4987953			100 BL	300 KK	2400 EK
K.SL.K.130.F1	4987954			100 BL	300 KK	2400 EK
K.SL.K.130.CW	4987955			100 BL	300 KK	2400 EK
K.SL.K.130.F3-MG	5014723			100 BL	300 KK	2400 EK
K.SL.K.130.F1-ELOX.	5024312			100 BL	300 KK	2400 EK
K.SK.WS	2845285			100 BL	600 KK	14400 EK
K.SK.BR	4927421			100 BL	600 KK	14400 EK
K.SK.CW	4927572			100 BL	600 KK	4800 EK
K.SK.F1	4928484			100 BL	600 KK	4800 EK
K.SK.F3	4995009			100 BL	600 KK	4800 EK
K.SK.F3-MG	4987480			100 BL	600 KK	4800 EK
K.SK.BZ-RB	4933296			100 BL	600 KK	4800 EK
K.SK.F9	2845293			100 BL	600 KK	14400 EK
K.SK.LBR	4939036			100 BL	600 KK	4800 EK
K.SK.SW	4939055			100 BL	600 KK	4800 EK

AGR = anthracite grey, BR = brown, BZ-AM = bronze - antique brass, BZ-RB = bronze - red brown, BZ-CU = bronze coppery, CW = creme white, EV1 = anodised silver, F1 = silver colour, F1-elox = sim. to F1 anodised silver, F3 = gold colour, F3-MG = gold mat, F9 = titanium coloured, LBR = clay brown, PW = pearl white, SG = silver grey, SGB = grey, SGR = dusty grey, SL = silver look (zinc galvanised), SW = jet black, WS = white

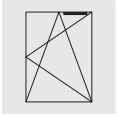
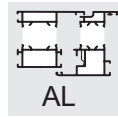
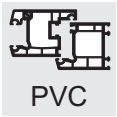

Additional shear ZSR SL

- Airgap 12 mm
- Overlap 18 to 22 mm
- For width FFB > 1475 mm
- Screw-connect-type frame plate preadjusted for insertion of WSK part (profile-dependent, see Group 11)
- Installation situation see Group 15, installation drawings B-7-4
- Profile adaption using adapters FT - WSK see group Frame Parts

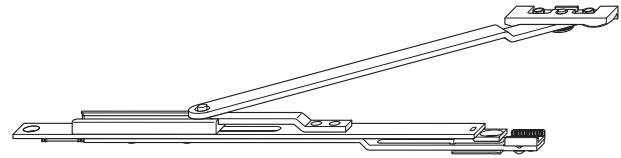

Additional shear ZSR.13-3

- As described above
- Frame plate designed for 13 mm groove centre position and 3 mm chamfer behind the glazing bead with groove

Additional shear ZSRE SL

- Use in turn-tilt windows with operating sequence tilt before turn
- In all other respects construction is the same as additional shear ZSR
- Installation situation see group 15, installation drawings B-7-5

Additional shear ZSRE.13-3

- As described above
- Frame plate designed for 13 mm groove centre position and 3 mm chamfer behind the glazing bead with groove

Item description	Item No.	Scope of application		VPA1 Qty./Type	VPA2 Qty./Type	VPA3 Qty./Type
ZSR SL	5048941	FFB > 1475	4	10 BD	80 KK	640 EK
ZSR.13-3	5054240	FFB > 1475	4	10 BD	80 KK	640 EK
ZSRE SL	5048946	FFB > 1475	4	10 BD	80 KK	640 EK
ZSRE.13-3	5054241	FFB > 1475	4	10 BD	80 KK	640 EK

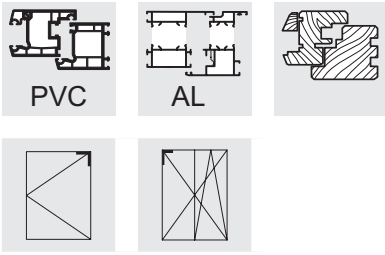

Turn hinge DL.K ... 9

- Used in combination with shear hinges SL.KS, SL.KB or SL.HW
- Available for mounting left and right hand
- Integrated turn restriction via plastic sleeve in shear hinge
- Adjustment for lifting and lowering the sash (+3/-2 mm)
- Pressure adjustment: +/- 0.8 mm
- Groove centre position 9 mm
- Max. sash weight 130 kg

Top hinge bracket DLW ERW

- Can be used left and right hand
- Automatic and manual assembly possible
- Used to hold the turn hinge DLB
- Clampable in fitting groove

Shear hinge cap K.SK

- Can be used left and right hand
- See shear hinge SL.KS, SL.KB, SL.HW
- Available in different colours

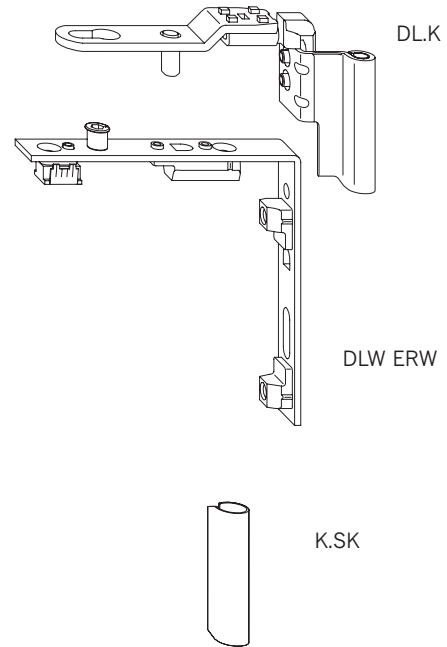

Item description	Item No.		Overlap	Groove centre position	VPA1 Qty./Type	VPA2 Qty./Type
DLW ERW SL	2300023	4			100 KK	800 EK
DL.K.18-9.LS	4998754	0	18	9	100 KK	800 EK
DL.K.18-9.RS	4998753	0	18	9	100 KK	800 EK
DL.K.18-9.LS.WS	4998756	0	18	9	100 KK	800 EK
DL.K.18-9.RS.WS	4998755	0	18	9	100 KK	800 EK
DL.K.18-9.LS.F9	4998758	0	18	9	100 KK	800 EK
DL.K.18-9.RS.F9	4998757	0	18	9	100 KK	800 EK
DL.K.20-9.LS	4928091	0	20	9	100 KK	800 EK
DL.K.20-9.RS	4928090	0	20	9	100 KK	800 EK
DL.K.20-9.LS.WS	4928095	0	20	9	100 KK	800 EK
DL.K.20-9.RS.WS	4928093	0	20	9	100 KK	800 EK
DL.K.20-9.LS.F9	4928097	0	20	9	100 KK	800 EK
DL.K.20-9.RS.F9	4928096	0	20	9	100 KK	800 EK

RS = right, LS = left

WS = white, BR = brown, SL = silver, F1 = silver coloured, F3 = gold coloured, F9 = titanium coloured

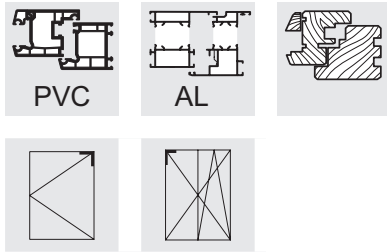

Turn hinge DL.K ... 13

- Used in combination with shear hinges SL.KS, SL.KB or SL.HW
- Available for mounting left and right hand
- Integrated turn restriction via plastic sleeve in shear hinge
- Adjustment for lifting and lowering the sash (+3/-2 mm)
- Pressure adjustment: +/- 0.8 mm
- Groove centre position 13 mm
- Max. sash weight 130 kg

Top hinge bracket DLW ERW

- Can be used left and right hand
- Automatic and manual assembly possible
- Used to hold the turn hinge DLB
- Clampable in fitting groove

Shear hinge cap K.SK

- Can be used left and right hand
- See shear hinge SL.KS, SL.KB, SL.HW
- Available in different colours

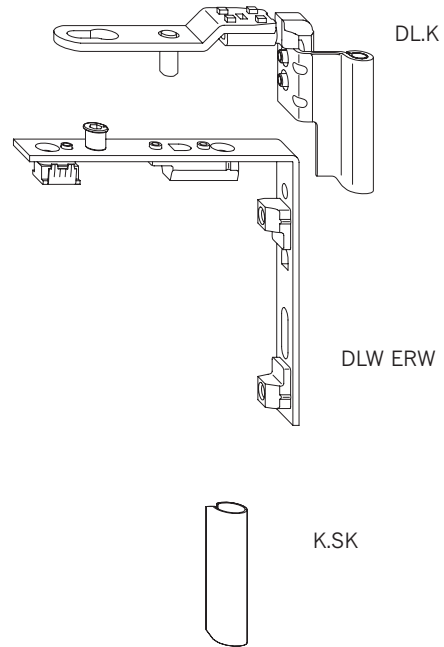

Item description	Item No.		Overlap	Groove centre position	VPA1 Qty./Type	VPA2 Qty./Type
DLW ERW SL	2300023	4			100 KK	800 EK
DL.K.18-13.LS.WS	4998762	0	18	13	100 KK	800 EK
DL.K.18-13.RS.WS	4998761	0	18	13	100 KK	800 EK
DL.K.18-13.LS.F9	4998764	0	18	13	100 KK	800 EK
DL.K.18-13.RS.F9	4998763	0	18	13	100 KK	800 EK
DL.K.20-13.LS	4926931	0	20	13	100 KK	800 EK
DL.K.20-13.RS	4926930	0	20	13	100 KK	800 EK
DL.K.20-13.LS.WS	2903203	0	20	13	100 KK	800 EK
DL.K.20-13.RS.WS	2903191	0	20	13	100 KK	800 EK
DL.K.20-13.LS.BR	4926808	0	20	13	100 KK	800 EK
DL.K.20-13.RS.BR	4926807	0	20	13	100 KK	800 EK
DL.K.20-13.LS.CW	4928069	0	20	13	100 KK	800 EK
DL.K.20-13.RS.CW	4928068	0	20	13	100 KK	800 EK
DL.K.21-13.LS	4926283	0	21	13	100 KK	800 EK
DL.K.21-13.RS	4926282	0	21	13	100 KK	800 EK
DL.K.21-13.LS.F9	4926287	0	21	13	100 KK	800 EK
DL.K.21-13.RS.F9	4926286	0	21	13	100 KK	800 EK
DL.K.22-13.LS	4935775	0	22	13	100 KK	800 EK
DL.K.22-13.RS	4935774	0	22	13	100 KK	800 EK

RS = right, LS = left

AGR = anthracite grey, BR = brown, BZ-AM = bronze - antique brass, BZ-RB = bronze - red brown, BZ-CU = bronze coppery, CW = creme white, EV1 = anodised silver, F1 = silver colour, F1-elox = sim. to F1 anodised silver, F3 = gold colour, F3-MG = gold mat, F9 = titanium coloured, LBR = clay brown, PW = pearl white, SG = silver grey, SGB = grey, SGR = dusty grey, SL = silver look (zinc galvanised), SW = jet black, WS = white

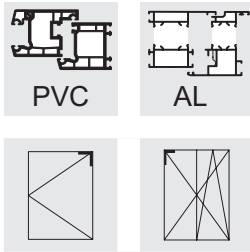

Turn hinges DL.K.ET

- Corner bracket and turn hinge are firmly connected to each other
- Available for mounting left and right hand
- Integrated turn restriction via plastic sleeve in shear hinge
- Adjustment for lifting and lowering the sash (+3/-2 mm)
- Pressure adjustment: +/- 0.8 mm
- Max. sash weight 130 kg

Shear hinge cap K.SK

- Can be used left and right hand
- See shear hinge SL.KS, SL.KB, SL.HW

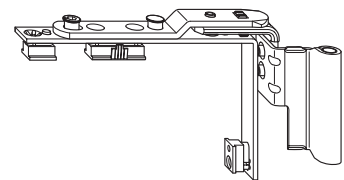

DL.K.ET



K.SK

Item description	Item No.		Overlap	Groove centre position	VPA1 Qty./Type	VPA2 Qty./Type	VPA3 Qty./Type
DL.K.ET.18-9.LS	4986905	4	18	9	10 BD	100 GK	400 EK
DL.K.ET.18-9.RS	4986904	4	18	9	10 BD	100 GK	400 EK
DL.K.ET.20-9.LS	4986907	4	20	9	10 BD	100 GK	400 EK
DL.K.ET.20-9.RS	4986906	4	20	9	10 BD	100 GK	400 EK
DL.K.ET.20-10.LS	4994957	4	20	10	10 BD	100 GK	400 EK
DL.K.ET.20-10.RS	4994956	4	20	10	10 BD	100 GK	400 EK
DL.K.ET.20-13.LS.BR	4978153	4	20	13	10 BD	100 GK	400 EK
DL.K.ET.20-13.RS.BR	4978152	4	20	13	10 BD	100 GK	400 EK
DL.K.ET.20-13.LS.F9	4978151	4	20	13	10 BD	100 GK	400 EK
DL.K.ET.20-13.RS.F9	4978150	4	20	13	10 BD	100 GK	400 EK
DL.K.ET.20-13.LS.WS	4978149	4	20	13	10 BD	100 GK	400 EK
DL.K.ET.20-13.RS.WS	4978146	4	20	13	10 BD	100 GK	400 EK
DL.K.ET.20-13.PLS	5017999	4	20	13	10 BD	100 GK	400 EK
DL.K.ET.20-13.PRS	5017998	4	20	13	10 BD	100 GK	400 EK

RS = right, LS = left

WS = white, BR = brown, SL = silver, F1 = silver coloured, F3 = gold coloured, F9 = titanium coloured

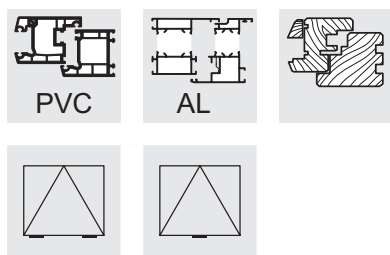

Tilt hinge KB.K

- Clampable in fitting groove
- Max. sash weight 80 kg
- Visible parts available in various colours
- In combination with shear hinge SL.KS, SL.KB, SL.HW

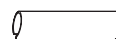
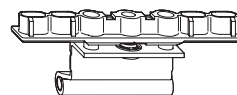

Shear hinge cap K.SK

- Can be used left and right hand
- Plastic cover for the shear hinge
- Available in different colours
- See shear hinge SL.KS, SL.KB, SL.HW

Item description	Item No.		Max. sash weight (kg)	Overlap	Groove centre position	VPA1 Qty./Type	VPA2 Qty./Type	VPA3 Qty./Type
KB.K.18-9	4999683	4	80	18	9	10 BL	100 KK	800 EK
KB.K.18-9.WS	4999684	4	80	18	9	10 BL	100 KK	800 EK
KB.K.18-9.F9	4999685	4	80	18	9	10 BL	100 KK	800 EK
KB.K.18-13	4999686	4	80	18	13	10 BL	100 KK	800 EK
KB.K.18-13.F9	4999688	4	80	18	13	10 BL	100 KK	800 EK
KB.K.20-9	4928109	4	80	20	9	10 BL	100 KK	800 EK
KB.K.20-9.WS	4928110	4	80	20	9	10 BL	100 KK	800 EK
KB.K.20-9.F9	4928113	4	80	20	9	10 BL	100 KK	800 EK
KB.K.20-10	4994958	4	80	20	10	10 BL	100 KK	800 EK
KB.K.20-13	4926935	4	80	20	13	10 BL	100 KK	800 EK
KB.K.20-13.WS	2903297	4	80	20	13	10 BL	100 KK	800 EK
KB.K.20-13.F9	2903300	4	80	20	13	10 BL	100 KK	800 EK
KB.K.20-13.BR	4926805	4	80	20	13	10 BL	100 KK	800 EK
KB.K.20-13.CW	4928070	4	80	20	13	10 BL	100 KK	800 EK
KB.K.21-13	4926313	4	80	21	13	10 BL	100 KK	800 EK
KB.K.21-13.WS	4926314	4	80	21	13	10 BL	100 KK	800 EK
KB.K.21-13.F9	4926315	4	80	21	13	10 BL	100 KK	800 EK
KB.K.21-13.BR	4926316	4	80	21	13	10 BL	100 KK	800 EK
KB.K.22-13	4935772	4	80	22	13	10 BL	100 KK	800 EK

AGR = anthracite grey, BR = brown, BZ-AM = bronze - antique brass, BZ-RB = bronze - red brown, BZ-CU = bronze coppery, CW = creme white, EV1 = anodised silver, F1 = silver colour, F1-elox = sim. to F1 anodised silver, F3 = gold colour, F3-MG = gold mat, F9 = titanium coloured, LBR = clay brown, PW = pearl white, SG = silver grey, SGB = grey, SGR = dusty grey, SL = silver look (zinc galvanised), SW = jet black, WS = white

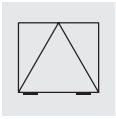
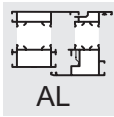
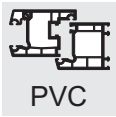

Tilt hinge KLB

- In combination with shear hinge SL.KS, SL.KB, SL.HW
- Available for mounting left and right hand
- Integrated turn restriction via plastic sleeve in shear hinge
- Adjustment for lifting and lowering the sash (+3/-2 mm)
- Pressure adjustment: +/- 0,8 mm
- Use in combination with top hinge bracket DLW ERW
- Max. sash weight: 80 kg

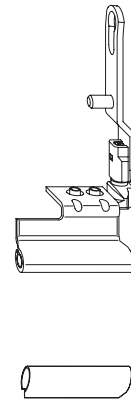

8

Shear hinge cap K.SK

- Can be used left and right hand
- See shear hinge SL.KS, SL.KB, SL.HW

Item description	Item No.		Overlap	Groove centre position	Max. sash weight (kg)	VPA1 Qty./Type	VPA2 Qty./Type
DLW ERW SL	2300023	4				100 KK	800 EK
KLB.20-9.LS.WS	4928531		20	9	80	100 KK	800 EK
KLB.20-9.RS.WS	4928530		20	9	80	100 KK	800 EK
KLB.20-9.LS.F9	4928533		20	9	80	100 KK	800 EK
KLB.20-9.RS.F9	4928532		20	9	80	100 KK	800 EK
KLB.20-13.LS	4928514		20	13	80	100 KK	800 EK
KLB.20-13.RS	4928513		20	13	80	100 KK	800 EK
KLB.20-13.LS.WS	4928517		20	13	80	100 KK	800 EK
KLB.20-13.RS.WS	4928515		20	13	80	100 KK	800 EK
KLB.20-13.LS.BR	4928521		20	13	80	100 KK	800 EK
KLB.20-13.RS.BR	4928520		20	13	80	100 KK	800 EK
KLB.20-13.LS.F9	4928519		20	13	80	100 KK	800 EK
KLB.20-13.RS.F9	4928518		20	13	80	100 KK	800 EK

RS = right, LS = left

WS = white, BR = brown, SL = silver, EV1 = anodised silver, F1 = silver colour, F3 = gold colour, BZ-RB = bronze red brown, F9 = titanium coloured, CW = creme white

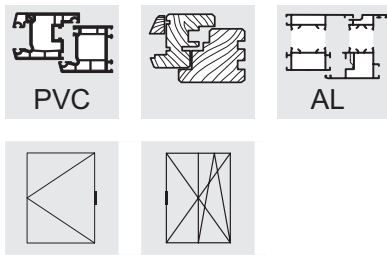

Turn middle hinge DML.K ...

- Used in combination with shear hinges SL.KS, SL.KB or SL.HW
- Integrated turn restriction via plastic sleeve in shear hinge
- Vertical and lateral float mounting
- Pressure adjustment: +/- 0.8 mm
- Can be used left and right hand

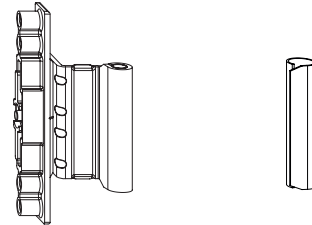

Turn middle hinge DML.K ... P

- Same design as above, but plus 1 mm contact pressure

Shear hinge cap K.SK

- Plastic cover for the shear hinge
- Available in different colours
- See shear hinge SL.KS, SL.KB, SL.HW
- Can be used left and right hand

Item description	Item No.		Groove centre position	Overlap	VPA1 Qty./Type	VPA2 Qty./Type	VPA3 Qty./Type
DML.K.20-10	5016271	4	10	20	10 BL	100 KK	800 EK
DML.K.20-13	5016272	4	13	20	10 BL	100 KK	800 EK
DML.K.20-9	5016270	4	9	20	10 BL	100 KK	800 EK
DML.K.20-13.P	5016273	4	13	20	10 BL	100 KK	800 EK

A silver colour is standard for visible components (zinc galvanised)

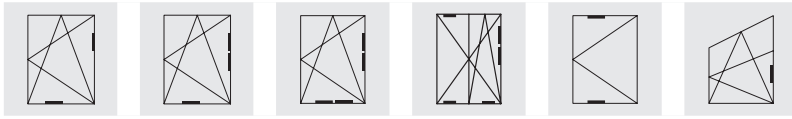
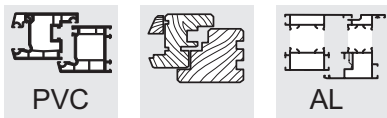

Interlocking rod M

- Central fastening loosens automatically by tightening fitting screw
- Functional both vertically and horizontally
- Clampable in fitting groove

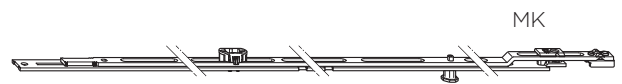
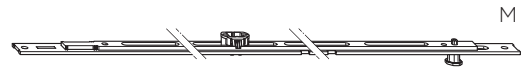

Interlocking rod MK

- Extendable interlocking rod, can be combined with Winkhaus standard gearing
- Otherwise this design is identical to interlocking rod M

Interlocking rod M/MK ... C

- Same construction as M/MK..., but with additional clamping piece

Interlocking rod MB

- Design is identical to interlocking rod M, but with increased lengths for the hinge side

Interlocking rod MK ... BS

- The components specially developed for threshold solutions (sash and frame side) can be gathered from the catalogue "Complementary range activPilot threshold components...".

9

Item description	Item No.		VPA1 Qty./Type	VPA2 Qty./Type	VPA3 Qty./Type
M.250-1	2822471	2	20 BD	100 KK	800 EK
M.350-1	5012660	2	20 BD	100 KK	2400 EK
M.500-1	4933994	3	20 BD	100 GK	1200 EK
M.500-1.C	4933999	3	20 BD	100 GK	1200 EK
M.750-1	4940652	5	20 BD	500 EA	
MK.150-1	5043228	2	20 BD	100 KK	800 EK
MK.250-0	4929185	2	20 BD	100 KK	800 EK
MK.250-1	2824919	2	20 BD	100 KK	800 EK
MK.500-0	4929187	3	20 BD	500 EA	
MK.500-0.C	4932315	3	20 BD	500 EA	
MK.500-1	2824986	3	20 BD	500 EA	
MK.500-1.C	4932287	3	20 BD	500 EA	
MK.750-1	4940653	5	20 BD	500 EA	
MK.750-2	5009140	5	20 BD	500 EA	
MB.1000-2	5018552	5	10 BD	400 EA	
MB.1250-2	4942625	7	10 BD	400 L1	
MB.1450-2	4942626	8	10 BD	400 L1	
MB.1750-3	4942627	10	10 BD	400 L1	

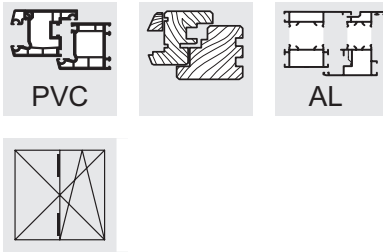

Interlocking rod MS.SU

- For fitting vertically below the double-sash drive rod
- Safety keeps are generally pre-assembled
- Clampable in fitting groove
- Designed for 12 mm airgap
- Central fastening loosens automatically by tightening fitting screw

Interlocking rod MS.SO

- For fitting vertically above the double-sash drive rod
- Otherwise this type is identical to interlocking rod MS.SU

MS.SU.



MS.SO.



Item description	Item No.	 Qty./Type	VPA1 Qty./Type	VPA2 Qty./Type	VPA3 Qty./Type
MS.SO.250-1	4934014	2	20 BD	100 KK	800 EK
MS.SO.500-1	2838982	4	20 BD	2700 EA	
MS.SU.250-1	4933801	2	20 BD	100 KK	800 EK
MS.SU.500-1	2838464	4	20 BD	2700 EA	

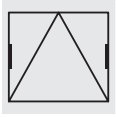
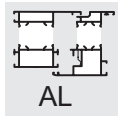
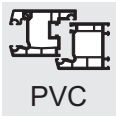

Interlocking rod MK.250.0-HA

- For tilt windows
- In combination with safety shears (brand: Hautau)
- Designed for 12 mm airgap
- Central fastening loosens automatically by tightening fitting screw



9

Item description	Item No.		VPA1 Qty./Type	VPA2 Qty./Type	VPA3 Qty./Type
MK.250.0-HAUTAU	5044624	2	20 BD	100 KK	800 EK

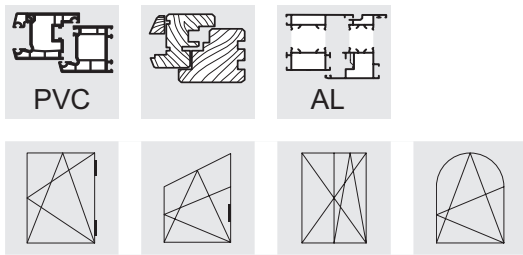

Coupling element KE

- Application area: connecting two gear ends (tooth shoes), e.g. corner drive E1 with an interlocking rod MK
- Clampable in fitting groove
- Functional both vertically and horizontally
- Central fastening loosens automatically by tightening fitting screw
- Cutting area 250 mm
- Component length 510 mm

Coupling element KE.500-1.RC-N

- As described above
- Cutting area 250 mm
- Component length 500 mm
- Includes one locking point

Coupling element KE.500-1.SO.RC-N

- As described above
- With a welded keep
- Matching part of KE.500-1.RC-N for face plate area

Connection rod VS RB SL

- Connection between round arch set (Chapter 7) and standard gearing

Connection rod VS RB-K SL

- Connection between round arch set (Chapter 7) and standard gearing
- For small window heights see Group 1, lists of fittings

Connection piece VBST

- Application area: connecting two gear ends (tooth shoes), e.g. corner drive E1 with an interlocking rod MK
- Clampable in fitting groove
- Functional both vertically and horizontally
- Fixed in the centre
- Cutting area 250 mm
- Length of component 370 mm

KE SL KE.500-1.SO.RC-N KE.500-1.RC-N VBST

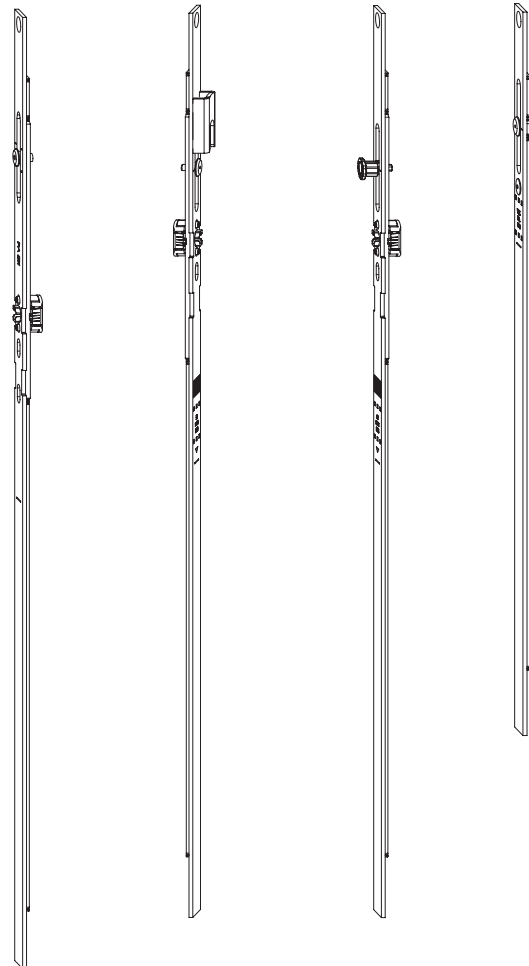

Item description	Item No.		VPA1 Qty./Type	VPA2 Qty./Type	VPA3 Qty./Type
KE SL	4982891	1	10 BD	1000 EA	
KE.500-1.RC-N	5043229	1	10 BD	1000 EA	
KE.500-1.SO.RC-N	5043230	1	10 BD	1000 EA	
VS RB SL	1811411	0	10 BD	100 GK	400 EK
VS RB-K SL	1811420	1	10 BD	100 KK	800 EK
VBST.370.RC-N	5043231	1	10 BD	100 GK	400 EK

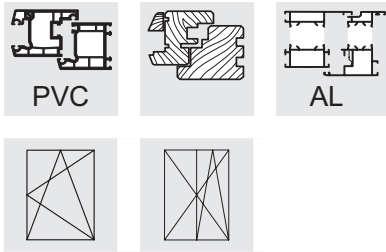

Extension rod V.AK.450-1

- Used to position a locking point near the sash hinge (up to RC2 / RC2 N)
- Functional both vertically and horizontally
- Not extendable
- Clampable in fitting groove
- Component length 450 mm
- Cutting area 250 mm

9

Extension rod VK.AK.450-1

- Same construction as described above, but it can be connected to Winkhaus standard gearing

Extension rod V.AK.450-1.BS16

- The components specially developed for threshold solutions (sash and frame side) can be gathered from the catalogue "Complementary range activPilot threshold components...".

V.AK.450-1

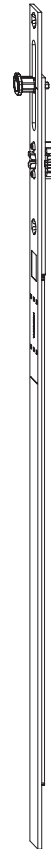

VK.AK.450-1



Item description	Item No.		VPA1 Qty./Type	VPA2 Qty./Type	VPA3 Qty./Type
V.AK.450-1	4942706	3	10 BD	1000 EA	
VK.AK.450-1	5002559	2	20 BD	100 GK	400 EK

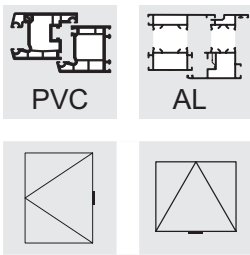

Pull-in device ZV-FT SL

- Central locking device for turn-only windows
- Assembly on the sash
- Concealed in the rebate
- Adjustable for airgaps of 11 to 14 mm
- In combination with ZV-RT SL frame parts

Keep ZV-RT SL

- Central locking device for turn-only windows
- Installation on the frame
- Concealed in the rebate
- For rebate clearance of 11 to 14 mm
- Profile attribution see keep overview

ZV-FT

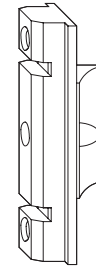

ZV-RT



Item description	Item No.		Groove centre position	VPA1 Qty./Type	VPA2 Qty./Type	VPA3 Qty./Type
ZV-FT SL	2359324	2	9/13	10 BL	100 KK	800 EK

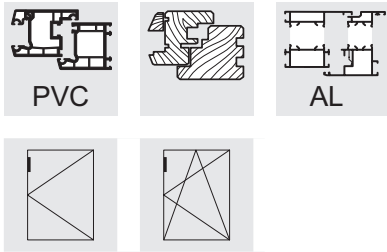

Extension rod MK.250.FSF

- Functional parts such as fail safe device FSF and dual function element DFE retrofittable
- Extension rod cannot be cut to length
- Face plate length 250 mm
- For tall windows with low handle position
- Installation position on the upper drive side

Please observe for dual function element DFE

- The DFE dual function element for use with the MK.250.FSF as fail safe device can basically only be used for 1-sash window units. For 2-sash units it is only possible if the fitting groove of the stationary sash is free (for holding a keep with frame part DFE/TFE).

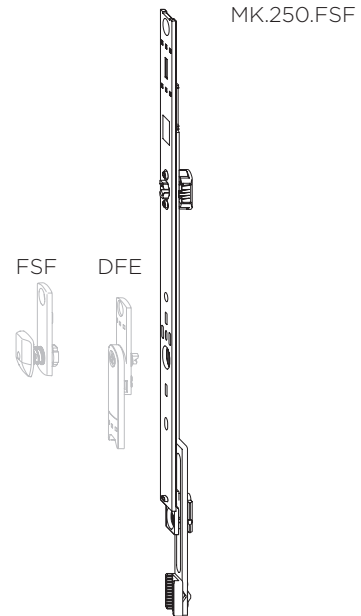

9

Item description	Item No.		VPA1 Qty./Type	VPA2 Qty./Type	VPA3 Qty./Type
MK.250.FSF	5009920	3	20 BD	100 KK	800 EK

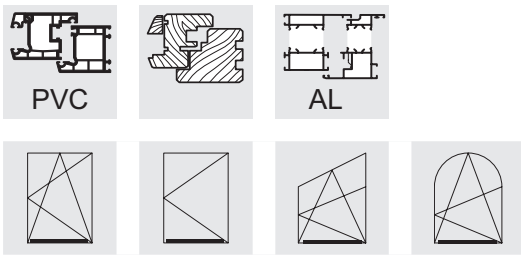

Connection rod VSAM



- One-piece connection rod for linking two corner drives
- For radius head and studio windows
- Can be used left and right hand
- Mounted in centre
- Locking positions identical to GAM drive rod range

Item description	Item No.	Scope of application		VPA1 Qty./Type	VPA2 Qty./Type	VPA3 Qty./Type
VSAM.800	5014974	FFH/FFB 510 - 800	2	20 BD	400 EA	
VSAM.1050	5014975	FFH/FFB 710 - 1050	2	20 BD	400 EA	
VSAM.1050-1	5014976	FFH/FFB 710 - 1050	2	20 BD	400 EA	
VSAM.1400-1	5014977	FFH/FFB 900 - 1400	4	20 BD	400 L1	
VSAM.1800-2	5014979	FFH/FFB 1300 - 1800	6	10 BD	400 L1	
VSAM.2300-3	5015010	FFH/FFB 1800 - 2300	9	10 BD	400 L2	900 EU2

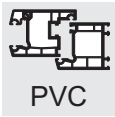

PVC



AL

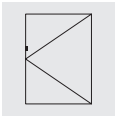
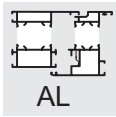

Handle sets

Handle set GG RN

- For glazed doors without blinds
- Sash thickness up to max. 70 mm
- Gap between handle and profile cylinder to match drives GAMA/GAKA
- Available in different colours
- Screw into place from the interior side of the sash

Handle set GG RR

- For glazed doors with blinds (exterior flat type)
- Sash thickness up to max. 70 mm
- Gap between handle and profile cylinder to match drives GAMA/GAKA
- Available in different colours
- Screw into place from the interior side of the sash

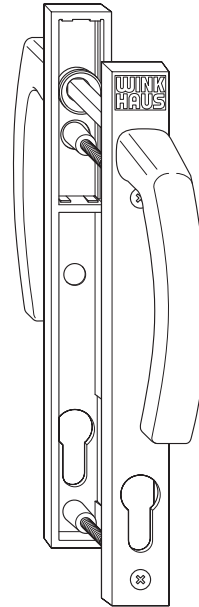

GG RN

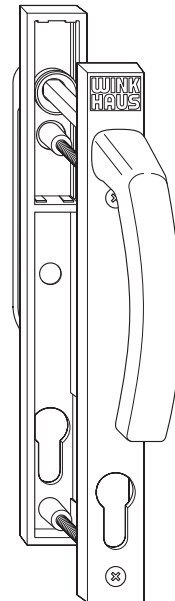

GG RR

Item description	Item No.	VPA1 Qty./Type	VPA2 Qty./Type	VPA3 Qty./Type
GG RN WS	2508641	1 KT	10 KK	80 EK
GG RN BR	2508633	1 KT	10 KK	80 EK
GG RN F1	2508561	1 KT	10 KK	80 EK
GG RN F9	2508650	1 KT	10 KK	80 EK
GG RR WS	2508684	1 KT	10 KK	80 EK
GG RR BR	2508676	1 KT	10 KK	80 EK
GG RR F9	2508692	1 KT	10 KK	80 EK

WS = white, BR = brown, SL = silver, F1 = silver coloured, F3 = gold coloured, F9 = titanium coloured

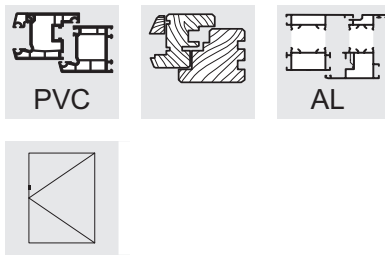

Handle sets

Handle set GG RNW

- For glazed doors without blinds
- Sash thickness up to max. 70 mm
- Gap between handle and profile cylinder to match drives GAMA/GAKA
- Available in different colours
- To adapt to flush-mounted profiles
- Screw into place from the interior side of the sash

Handle set GG RRW

- For glazed doors with blinds (exterior flat type)
- Sash thickness up to max. 70 mm
- Gap between handle and profile cylinder to match drives GAMA/GAKA
- Available in different colours
- To adapt to flush-mounted profiles
- Screw into place from the interior side of the sash

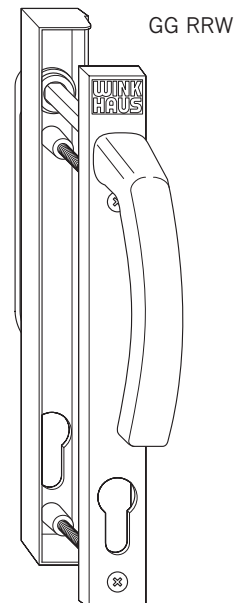
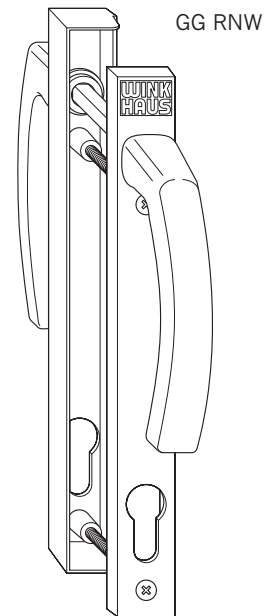

Item description	Item No.	VPA1 Qty./Type	VPA2 Qty./Type	VPA3 Qty./Type
GG RNW R74 LS WS	2508959	1 KT	10 KK	80 EK
GG RNW R74 RS WS	2508924	1 KT	10 KK	80 EK
GG RNW R74 LS F9	2508975	1 KT	10 KK	80 EK
GG RNW R74 RS F9	2508941	1 KT	10 KK	80 EK
GG RRW R74 LS WS	2508895	1 KT	10 KK	80 EK
GG RRW R74 RS WS	2508861	1 KT	10 KK	80 EK
GG RRW R74 LS F9	2508916	1 KT	10 KK	80 EK
GG RRW R74 RS F9	2508887	1 KT	10 KK	80 EK

RS = right, LS = left

WS = white, BR = brown, SL = silver, F1 = silver coloured, F3 = gold coloured, F9 = titanium coloured

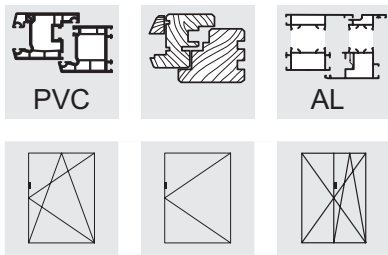

Dual and triple function element

Dual function element DFE

- For screwing onto the drive rod
- DFE includes the fail safe device and limiter support functions
- Centrally fixed when supplied and thus available for right and left-handed use
- Is activated on the sash after mounting
- See Group 14 for instructions on adjustment
- Max. sash weight 130 kg

Dual function element DFE.OF

- As described above, but without fail-safe device
- Function: only as support keep
- (without figure)

Dual function element DFE-P

- as above, but as a pendulum variant

Triple function element TFE

- For screwing onto the drive rod
- TFE includes the fail safe device, limiter support and balcony door catch
- Centrally fixed when supplied and thus available for right and left-handed use
- Is activated on the sash after mounting
- See Group 14 for instructions on adjustment
- Max. sash weight 130 kg



DFE



DFE-P



TFE

10

Item description	Item No.		VPA1 Qty./Type	VPA2 Qty./Type	VPA3 Qty./Type
DFE	4931451	1	50 BL	250 KK	2000 EK
DFE.OF	5001491	1	50 BL	250 KK	2000 EK
DFE-P	4932220	1	50 BL	250 KK	2000 EK
TFE	4931450	1	50 BL	250 KK	2000 EK

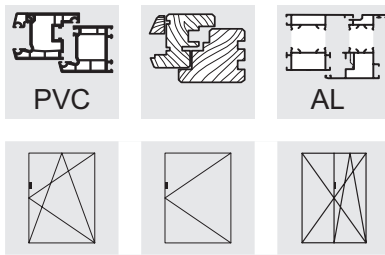

Frame parts RT.DFE-TFE

Frame part RT.DFE-TFE

- Serves as an adapter for dual or triple function element in standard security keeps SBS. ...
- Profile-independent as the adapter is fitted in the case of the security keeps
- Height adjustable (see Group 14)

Frame part RT.DFE-TFE LS/RS

- Serves as an adapter for dual or triple function element in standard security keeps SBS. ...
- Rear stop surface prevents the sash from overlapping
- Profile-independent as the adapter is fitted in the case of the security keeps
- Height adjustable (see Group 14)

Frame part RT.DFE-TFE.S

- Serves as an adapter for dual and triple function elements on double-sash drive rods
- Profile-independent as the adapter is fitted to the double-sash gear keeps
- Height adjustable (see Group 14)

Frame part RT.DFE-TFE.S LS/RS

- Serves as an adapter for dual and triple function elements on double-sash drive rods
- Rear stop surface prevents the sash from overlapping
- Profile-independent as the adapter is fitted to the double-sash gear keeps
- Height adjustable (see Group 14)

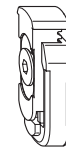

RT.DFE-TFE



RT.DFE-TFE.LS/RS



RT.DFE-TFE.S



RT.DFE-TFE.S.LS/RS

Item description	Item No.		VPA1 Qty./Type	VPA2 Qty./Type	VPA3 Qty./Type
RT.DFE-TFE.ZN	4937821	0	100 BL	500 KK	4000 EK
RT.DFE-TFE.LS	5017246	0	100 BL	500 KK	4000 EK
RT.DFE-TFE.RS	5017244	0	100 BL	500 KK	4000 EK
RT.DFE-TFE.S	4933544	0	100 BL	500 KK	4000 EK
RT.DFE-TFE.S.LS	4933547	0	100 BL	500 KK	4000 EK
RT.DFE-TFE.S.RS	4933545	0	100 BL	500 KK	4000 EK

RS = right, LS = left

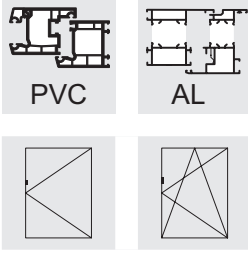

Balcony door catch BK SL

- For glazed doors with 12 mm air gap
- Light latching force when closing the door
- Improved retaining force
- Profile dependent see Group 11, Frame Parts
- Catch bolt BO BH-BK E SL included in the scope of delivery

Balcony door catch BK Z-8 SL

- Similar to BK balcony door catch, but with pins for positioning on the double-sash drive rod

Latch bolt BO BH-BK E SL

- Latch bolt for mounting on the drive rod

Latch bolt BO BK FC SL

- Latch bolt to be installed in the sash's fitting groove, positionable with machine

Balcony door catch BK BN SL

- Mounted into the fitting groove

BK SL



BK Z-8 SL

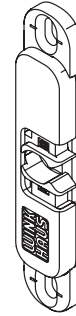

BK BN SL

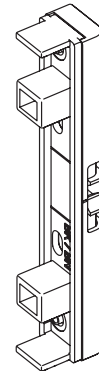

BO BK FC SL

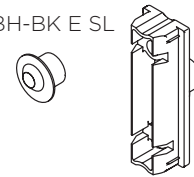

BO BH-BK E SL



Item description	Item No.		VPA1 Qty./Type	VPA2 Qty./Type	VPA3 Qty./Type
BK SL	1793250	2	100 KK	800 EK	
BK Z-8 SL	2446778	2	200 KK	1600 EK	
BO BH-BK E SL	1848732	1	100 BL	2000 KK	16000 EK
BO BK FC SL	2310977	2	100 BL	800 KK	6400 EK
BK BN SL	1848353	2	100 KK	800 EK	

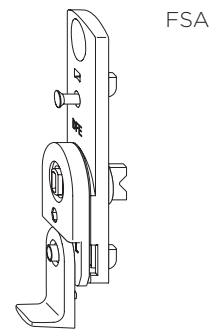
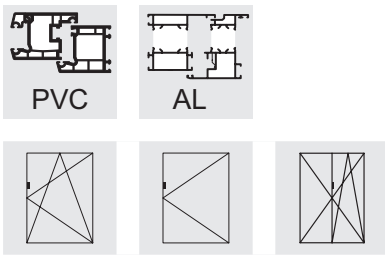

Fail safe device FSA

- For screwing onto the drive rod
- Prevents an actuation of the handle when the sash is open
- Centrally fixed when supplied and thus available for right and left-handed use
- Is activated on the sash after mounting
- Separate frame part is not necessary (hits the frame)
- For groove position 9 mm or 13 mm

Fail safe device FSF

- As described above
- With pressure piece for 9 mm and 13 mm groove centre position (separate frame part not necessary, pressure piece abuts to frame)

Fail-safe device FSF.C

- As mentioned above, but clampable in the drive rod

Fail-safe device FSF.13

- Identical to FSF, but with reinforced pressure part for 13 mm groove centre position

Fail safe device FSF.13.C

- As mentioned above, but clampable in the drive rod

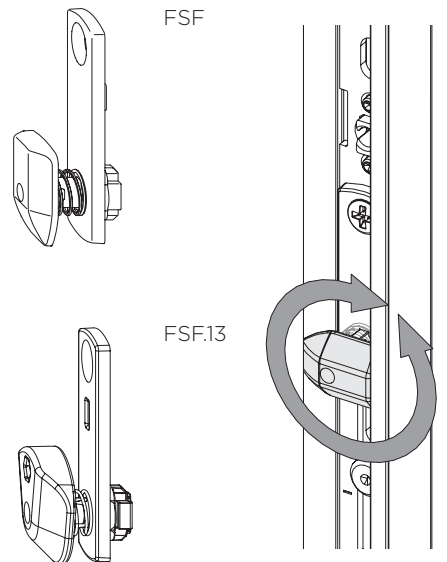

Item description	Item No.		Groove centre position	VPA1 Qty./Type	VPA2 Qty./Type	VPA3 Qty./Type
FSA.9	4940796	1	9	100 BL	500 KK	4000 EK
FSA.13	4926367	1	13	100 BL	500 KK	4000 EK
FSF	5031156	1	9/13	100 BL	500 KK	4000 EK
FSF.C	5034713	1	9/13	100 BL	500 KK	4000 EK
FSF.13	5055737	1	13	100 BL	500 KK	4000 EK
FSF.13.C	5066280	1	13	100 BL	500 KK	4000 EK

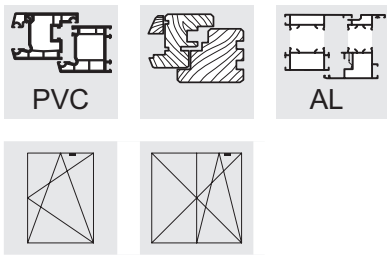

Variable tilt device MSL-OS

- Enables mini ventilation of approx. 20 - 45 mm in the tilt position
- Variable tilt device MSL.OS as retrofit option for window profiles with a frame rebate depth of 25 mm and 9 mm eurogroove position
- Simple mounting without tools
- MSL.OS can easily be retrofitted to the progressive shear retraction by pulling it up and inserting the MSL.OS device
- Can be retrofitted to all top rods OS ... with progressive shear retraction
- Right and left handed variants available

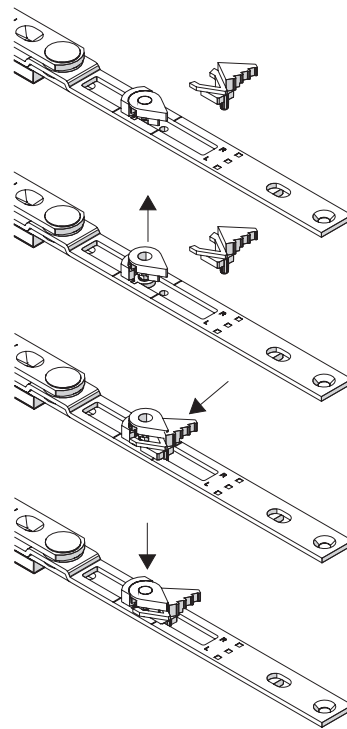
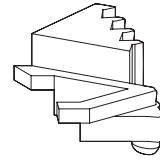

10

Item description	Item No.		VPA1 Qty./Type	VPA2 Qty./Type	VPA3 Qty./Type
MSL-OS.LS	4941704	0	50 BL	750 KK	6000 EK
MSL-OS.RS	4941703	0	50 BL	750 KK	6000 EK

RS = right, LS = left

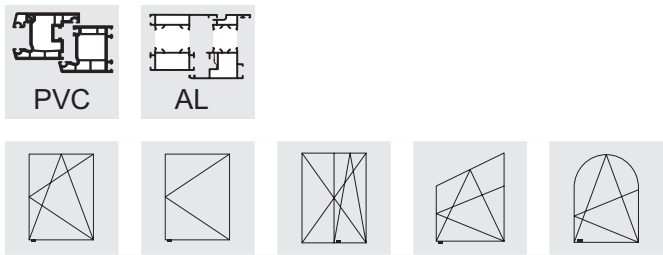

Keep on sash side

- For lifting the sash during closing

Support plate AL.M.F12

- For assembly in the suitable holes of the extension rod or for direct fitting in the sash-side fitting groove
- Installation height 11,5 mm
- Colour: anthracite grey or dusty grey

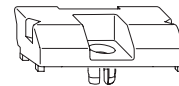

AL.M.F12

Support plate AL FR BN 13/12 FC SL

- Direct fitting in the eurogroove
- Installation height 11,5 mm
- Colour: silver

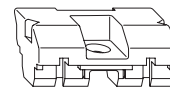

AL FR BN.../
AL.BN.F12

Support plate AL.BN.F12

- Direct fitting in the eurogroove
- Suitable for use on screwdriving units
- Installation height 11,5 mm
- Colour: anthracite grey

Support plate AL.E.F

- Is fixed to the corner drive on the sash side if no interlocking rod is used
- Suitable for use on screwdriving units
- Installation height 11,5 mm
- Colour: anthracite grey
- Not suitable for activPilot Comfort / duoPort PAS

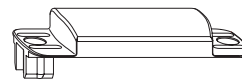

AL.E.F

Keep GRT.AL.F

- The components specially developed for threshold solutions (sash and frame side) can be gathered from the catalogue "Complementary range activPilot threshold components...".

Item description	Item No.		VPA1 Qty./Type	VPA2 Qty./Type	VPA3 Qty./Type
AL.M.F12.AGR	4927494	1	100 BL	400 KK	9600 EK
AL.M.F12.SGR	5008456	1	100 BL	400 KK	9600 EK
AL FR BN 13/12 FC SL	2295640	1	100 BL	400 KK	3200 EK
AL.BN.F12	4927493	1	100 BL	400 KK	9600 EK
AL.E.F	4933076	1	200 KK	1600 EK	

AGR = anthrazitgrau, SGR = staubgrau

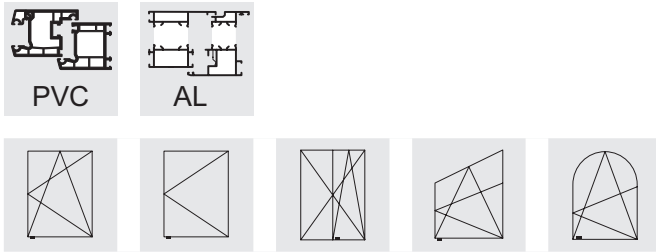

Keep on the frame side

- For lifting the sash during closing

Support plate AL D

- Installation in frame.
- Can be used for different profile systems thanks to adapter FT.WSK...
- Installation height 11 mm
- Colour: anthracite grey or white

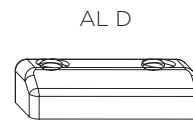

Support plate AL D 10 WS

- Installation in frame.
- Can be used for different profile systems thanks to adapter FT.WSK...
- Installation height 10 mm
- Colour white

Keep AL K.SBS.W

- Mounted into security keep SBS...
- Colour: dust grey similar to RAL 7037

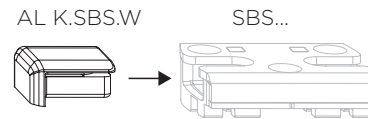

Threshold keep AL.SBK...BS

- The components specially developed for threshold solutions (sash and frame side) can be gathered from the catalogue "Complementary range activPilot threshold components...".

10

Item description	Item No.		VPA1 Qty./Type	VPA2 Qty./Type	VPA3 Qty./Type
AL D AGR	4969481	2	100 BL	400 KK	3200 EK
AL D WS	1475542	2	100 BL	400 KK	3200 EK
AL D 10 WS	2091583	2	100 BL	400 KK	3200 EK
AL K.SBS.W	4978509	0	100 BL	1000 KK	8000 EK

AGR = anthracite grey, WS = white

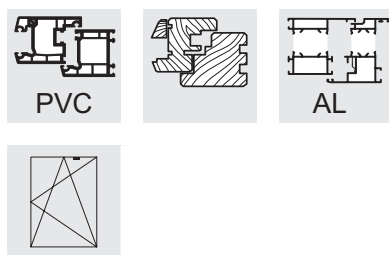

Accessories Top Rod OS

Anti-slam device ZSS.OS

- Can be used left and right hand
- Prevents tilted windows slamming shut in case of light draughts and low window sashes

- ZSS.OS1 for top rod OS1. ...
- ZSS.OS2 for top rod OS2. ...

Tilt limiter KBG.OS

- Can be used left and right hand
- Reduces tilt opening width by approx. 50 mm
- Recommended for use with sash heights below 600 mm

- KBG.OS1 for top rod OS1. ...
- KBG.OS2 for top rod OS2. ...

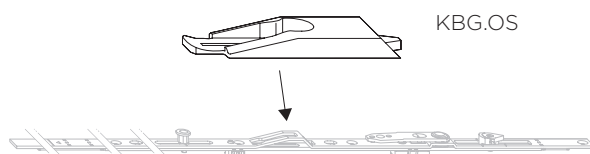
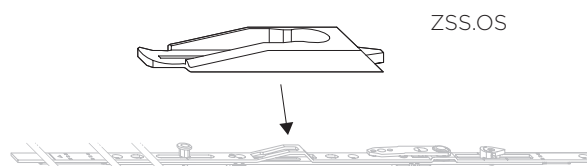

Item description	Item No.		VPA1 Qty./Type	VPA2 Qty./Type	VPA3 Qty./Type
ZSS.OS1	4936654	0	100 BL	1000 KK	8000 EK
ZSS.OS2	4936655	0	100 BL	1000 KK	8000 EK
KBG.OS1.SW	5053676	0	100 BL	1000 KK	8000 EK
KBG.OS2	5053677	0	100 BL	1000 KK	8000 EK

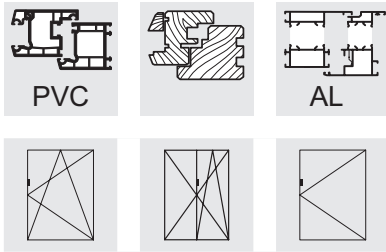

Drilling protection AB.G.D

- Protects the housing of drive units against being drilled open from the outside in line with DIN EN 1627-1630
- Can be used left and right hand
- Material: steel 1 mm thick, hardened

Drilling protection AB.G.D.15.5

- Backset 15.5 mm

Drilling protection AB.G.D.7.5

- Backset 7.5 mm

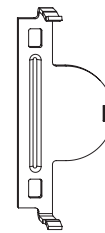

AB.G.D.15,5

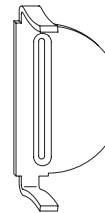

AB.G.D.7,5

10

Item description	Item No.	VPA1 Qty./Type	VPA2 Qty./Type	VPA3 Qty./Type
AB.G.D.15,5	4939745	100 BL	1000 KK	8000 EK
AB.G.D.7,5	4939747	50 BL	250 KK	2000 EK

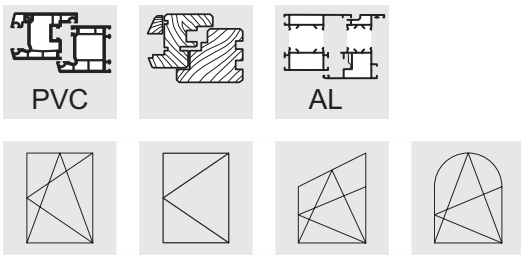

Blocking plate AWDR SL

- To arrest tilt position for turn-tilt fittings
- Can be used left and right hand

Blocking plate ANS ACP

- To arrest tilt position for turn-tilt fittings
- Can be used left and right hand
- PVC-U component to click into the corner drive

AWDR SL

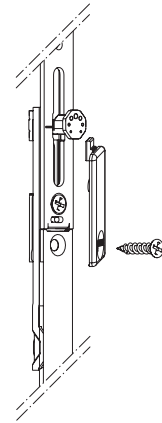
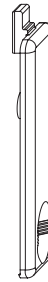

ANS ACP

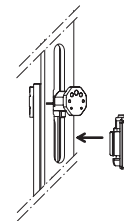
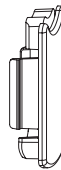

Item description	Item No.		VPA1 Qty./Type	VPA2 Qty./Type	VPA3 Qty./Type
AWDR SL	2308084	1	100 BL	1000 KK	8000 EK
ANS ACP	5009363	0	1000 BL	5000 KK	40000 EK

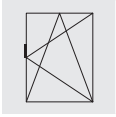
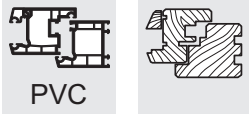

Opening limiter OBV

- For limiting the opening width independently of the control sequence
- Prevents the window from slamming shut
- Turn opening possible by two-hand control
- Protection against unintentional turn opening
- Automatic retainer: when the window is closed from the turn position, the opening limiter clicks back into place
- Limits opening width to approx. 50 mm when mounted on locking side; variable opening width possible if fitted horizontally
- Easy mounting due to height-adjustable frame parts
- Easy to maintain as the adjustment scope of the frame component is ± 3 mm
- For drilling and milling instructions see group 15, installation drawings B-10-2

Opening limiter OBVA

- Lockable version - Locking by means of Allen head screw
- Apart from that same construction as opening limiter OBV

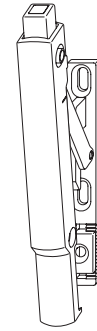

OBV

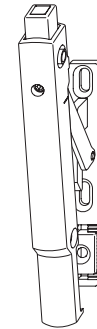

OBVA

Item description	Item No.		VPA1 Qty./Type	VPA2 Qty./Type	VPA3 Qty./Type
OBVWS	4929276	3	1 BL	100 KK	2400 EK
OBVBR	4929277	3	1 BL	100 KK	800 EK
OBV.SGB	4929755	3	1 BL	100 KK	800 EK
OBVA.WS	4929278	3	1 BL	100 KK	2400 EK
OBVA.BR	4929279	3	1 BL	100 KK	800 EK
OBVA.SGB	4929753	3	1 BL	100 KK	800 EK

WS = weiß, BR = braun, SGB = grau (ähnlich RAL 9006)

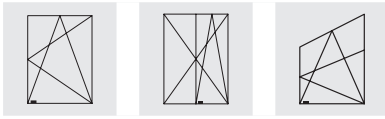
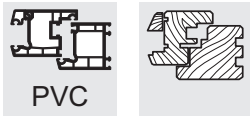

Window lock DS.24

- Lockable with special key
- Protection against unintentional turn opening
- Suitable for retrofit installation, independent of a arrangement of fittings
- Only usable with SBA. .. roller keep
- Required frame rebate depth >24 mm
- Can be used for sash overlap heights of 20 mm +2.5/-5 mm
- Consisting of:
 - 1 window lock
 - 2 screws DIN 965 M3 x 35
 - 4 packers FSV
- Rebate depth min. 22 mm in case of 9 mm groove centre position
- Rebate depth min. 26 mm in the case of 13 mm groove position
- For drilling and milling instructions see Group 15 installation drawings B-10-3
- The SLUE.DS.SL key must be ordered separately.
- We recommend you to order the jig for rotation stop device LE.DS.

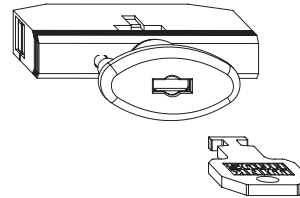

DS.24

SLUE.DS.SL

Rotation stop device DS.29

- Required frame rebate depth >29 mm
- Suitable for sash overlap heights of 25 mm +2.5/-5 mm

Key SLUE.DS.SL

- For activating the window lock

Jig for window lock FSV

- Drilling jig for pre-drilling the rotation stop device
- Passage drill hole on sash side

Item description	Item No.	VPA1 Qty./Type	VPA2 Qty./Type	VPA3 Qty./Type
DS.24.WS	5033454	10 BL	100 KK	800 EK
DS.24.BR	5033455	10 BL	100 KK	800 EK
DS.24.F9	5033456	10 BL	100 KK	800 EK
DS.29.WS	5033457	10 BL	100 KK	800 EK
DS.29.BR	5033458	10 BL	100 KK	800 EK
DS.29.F9	5033459	10 BL	100 KK	800 EK
SLUE FSV SL	2102246	10 BL	1000 KK	8000 EK
LE.FSV.ACTIVPILOT	4970409	10 KK	80 EK	

WS = white, BR = brown, SL = silver, F1 = silver coloured, F3 = gold coloured, F9 = titanium coloured

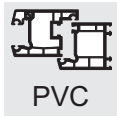

PVC



AL

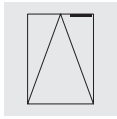
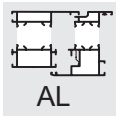

Rebate shear GRT FSR SL

- For tilt windows
- Sash weight max. 80 kg taking product liability in chapter "General Product Information" into account

Accessory: Packer UF BK WS

- Used as a mounting adapter between the sash eurogroove and the shear arm of the rebate shear
- Shade: white

Important:

- To secure the tilting sash in 90° opening position, or during cleaning, the window must also be fitted with standard cleaning or supporting shears.
- The sashes must be secured in cleaning position to prevent excessive force acting on the hinges.
- After cleaning the window, the rebate shear must be reinserted and secured.
- Close windows in case of wind and draft. Move the fitting to locking position.

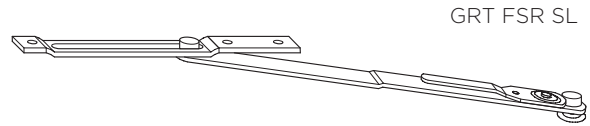

GRT FSR SL

UF BK WS



Item description	Item No.		VPA1 Qty./Type	VPA2 Qty./Type	VPA3 Qty./Type
GRT FSR SL	1811067	4	10 BD	150 KK	1200 EK
UF BK WS	1477943	2	100 BL	500 KK	4000 EK

WS = white, BR = brown, SL = silver

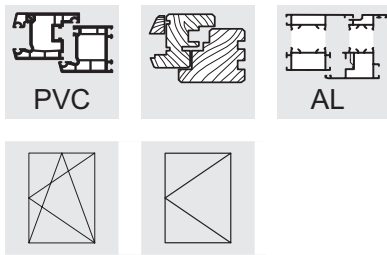

Connection rod VS R SL

- Used to connect two long parts with interlocking action

End plate ASP ER-A SL

- Serves as an end profile on corner drives or extensible interlocking rods to cover the connecting rod / the gearing

End plate ASP ER-A.F

- Design as described above, but clampable

Connecting plate SP.R SL

- For connecting a corner drive with a component that needs shortening, e.g. a drive rod or top rod
- Use only in case of repair, as a positive and non-positive fit is no longer guaranteed
- The element to be shortened can be cut straight

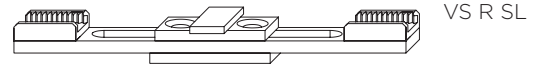

VS R SL

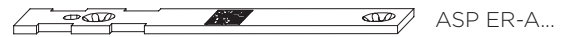

ASP ER-A...



SP R SL

Item description	Item No.		VPA1 Qty./Type	VPA2 Qty./Type	VPA3 Qty./Type
VS R SL	1882172	2	20 BL	100 KK	800 EK
ASP ER-A SL	1793209	2	500 KK	4000 EK	
ASP ER-A.F	4991062	2	500 KK	4000 EK	
SP.R SL	1934201	1	100 BL	1000 KK	8000 EK

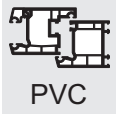

PVC

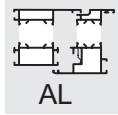

AL

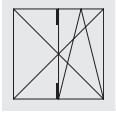

Shootbolt KR F 711

- For double-sash windows without a mullion
- Airgap 12 mm
- Locks into shootbolt keeps SA on top / bottom

Shootbolt KR 16/ ...

- Designed for 12 mm airgap
- Locks into shootbolt keeps SA on top / bottom
- Profile-dependent shootbolt keeps see chapter 11, Frame Parts
- Material: Steel

Shootbolt keep SA

- For wooden windows
- To hold the shootbolt interlock
- Depending on the profile
- Application scope see below

Shootbolt keep SA

- For PVC-U and aluminium windows
- To hold the shootbolt interlock
- Shootbolt keep SA see Group 11, Frame Parts

KR F 711



KR 16



10

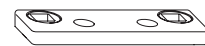

SA

Item description	Item No.	Scope of application		Length	VPA1 Qty./Type	VPA2 Qty./Type	VPA3 Qty./Type
KR F 711.C AGR	5026320		2		100 KK	800 EK	
KR F 711.C SL	5026321		2		100 KK	800 EK	
KR F 711.C SL/WS	5026322		2		100 KK	800 EK	
KR 16/200 SL	2070168		3	200	200 KK	1600 EK	
KR 16/500 SL	4941328		4	500	100 GK	400 EK	
SA VV 7 SL	1846913	EF 18	2		100 BL	500 KK	4000 EK
SA VV 80 SL	2921241	EN 7/8	2		100 BL	500 KK	4000 EK
SA VV 81 SL	2049801	EN 6/8	2		100 BL	500 KK	4000 EK

EF = standard rebate
EN = eurogroove

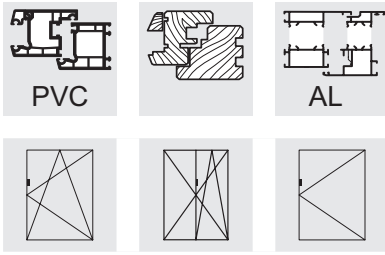

Faceplate fastener SNH.AGR

- For additional securing of the faceplate
- When short drive rods are used and in combination with corner drive E3.
- To screw on and retain the drive
- Profile-independent due to sash-side mounting.

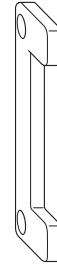

Item description	Item No.		VPA1 Qty./Type	VPA2 Qty./Type
SNH.AGR	4938874	2	400 KK	9600 EK

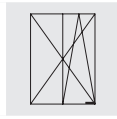
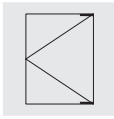
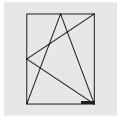
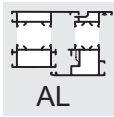
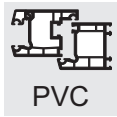

Turn limiter DB 11 SL

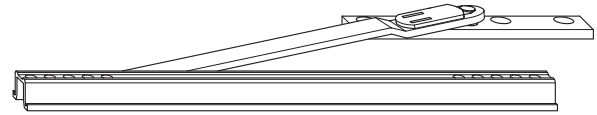

- Turn limiter to fit in existing fitting groove
- For additional sash hinge
- Friction adjustment with hexagonal span SW 4
- Screw-connect-type frame plate preadjusted for insertion of WSK part (profile-dependent, see Group 11)
- Also serves as an opening limiter
- The opening width of the sash can be adjusted on the turn limiter, according to the assembly position.
- Installation situation and adjustment of possible opening widths see group 15, installation drawings B-10-1

10

Turn limiter DB 11/1 SL

- For rebate sash hinges (FWV/FWSB/FL.HT)
- Installation situation see Group 15, installation drawings B-10-1

Turn limiter DB11-350 SL

- For screw-on sash hinges
- For sash rebate widths from 350 mm and more

Item description	Item No.	Scope of application		VPA1 Qty./Type	VPA2 Qty./Type
DB 11 SL	1848599	FFB > 460 mm	6	80 KK	640 EK
DB 11/1 SL	1848601	FFB > 640 mm	6	80 GK	320 EK
DB 11-350 SL	1848564	FFB > 350 mm	4	80 KK	640 EK

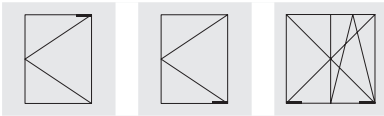
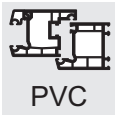

Window limiter FBP-11 650 SL

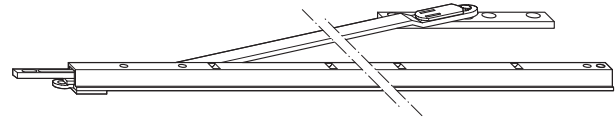

- FBP-11 650 SL for small sizes as of FFB > 480 mm
- For insertion into existing fitting groove
- Airgap 12 mm
- Various opening positions are achieved via the handle (in closed position) while the window is open, which is controlled via a rod connecting the FBP to the mechanism.
- Cannot be used in combination with a rebate sash hinge
- Screw-on frame plate, preadjusted for insertion of the WSK part (depending on profile)
- For assembly see chapter Mounting of Accessories
- Cannot be used with hinge parts (rebate sash hinge) assembled in the fitting groove

- Cannot be used for:
- Threshold solutions
- Tilt before turn
- activPilot Select - The fully concealed turn-tilt fitting.
- Resistance classes WK1, WK2, RC1, RC2
- Timber or aluminium profiles

Window Limiter FBP-11 SL

- See above
- FBP-11 SL only possible for sash rebate widths (FFB) > 630 mm

Spacer FT WSK

- Profile adaption using adapters FT - WSK see group Frame Parts

Item description	Item No.	Scope of application		VPA1 Qty./Type	VPA2 Qty./Type	VPA3 Qty./Type
FBP-11 650 SL	1997367	ab FFB 480 - 730	4	1 BL	50 GK	200 EK
FBP-11 SL	1997148	ab FFB 630 - ...	4	1 BL	50 GK	200 EK

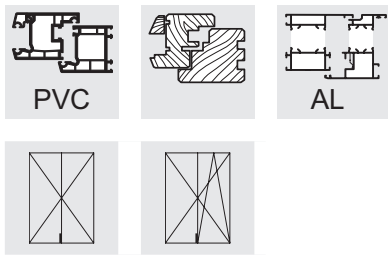

Catch bolt BK.KR

- Automatic catch bolt function with additional manual locking by means of a rod
- Used in combination with keep SA OF...
- Bolt can be locked and unlocked manually
- Can be used right/left and top/bottom
- Used on the inactive sash
- Positioning flush with the sash rebate edge
- Is activated when turn-tilt sash is opened
- The catch bolt retains the sash in the frame with light engagement forces, even if the rod is not locked.
- Length: 85 mm

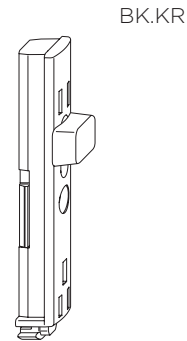

BK.KR

Keep SA OF H...

- For timber windows with 12 mm airgap
- Can be used left and right hand
- Pressure adjustment by turning the component (+ 0.5 mm)

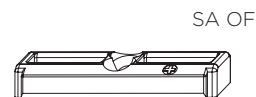

SA OF

Keep SA OF...

- As described above, but for PVC-U windows

Item description	Item No.		VPA1 Qty./Type	VPA2 Qty./Type	VPA3 Qty./Type
BK.KR.SGR	5008300	1	20 BL	100 KK	800 EK
BK.KR.WS	5008301	1	20 BL	100 KK	800 EK
SA OF H.9-18	5004589	2	300 KK	2400 EK	
SA OF H.13-22	5004588	2	300 KK	2400 EK	
SA OF 17 SL	4939996	2	50 BL	300 KK	2400 EK
SA OF 60 SL	2859521	2	50 BL	300 KK	2400 EK
SA OF 61 SL	4940007	2	50 BL	300 KK	2400 EK
SA OF 74 SL	4926924	2	300 KK	2400 EK	
SA OF 77 SL	4940953	2	300 KK	2400 EK	
SA OF 126 SL	2859513	2	50 BL	300 KK	2400 EK
SA OF 144 SL	2859530	2	50 BL	300 KK	2400 EK
SA OF 152 SL	2859505	2	50 BL	300 KK	2400 EK
SA OF 161 SL	5031823	2	50 BL	300 KK	2400 EK
SA OF 169 SL	5019156	2	50 BL	300 KK	2400 EK
SA OF 192 SL	4932035	2	50 BL	300 KK	2400 EK
SA OF H.7/8-9	5049091	2	300 KK	2400 EK	

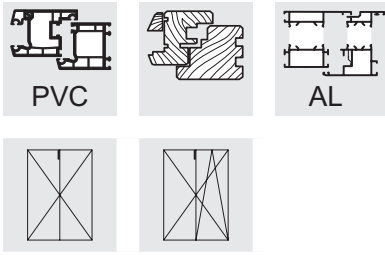

Automatic deadbolt AKR ...

- Used in combination with keep SA OF...
- The rod is extended by closing the active sash.
- Installation position upper fitting groove
- Unlocking by means of spring action when first-opening sash is opened

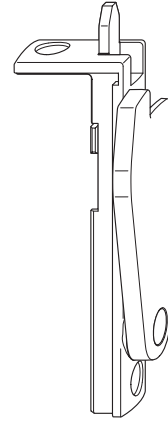

Item description	Item No.		VPA1 Qty./Type	VPA2 Qty./Type	VPA3 Qty./Type
AKR LS.WS	5008299	2	20 BL	100 KK	800 EK
AKR RS.WS	5008298	2	20 BL	100 KK	800 EK
AKR LS.SGR	5008297	2	20 BL	100 KK	800 EK
AKR RS.SGR	5008295	2	20 BL	100 KK	800 EK

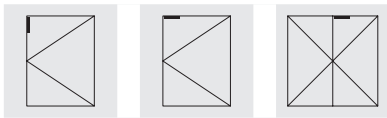
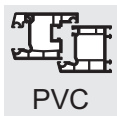

Mini ventilation unit AS DSL... (turn position)

- Mini ventilation for turn windows
- Mini ventilation position among others with standard activPilot corner drive
- Opening width approx. 70 mm, according to the profile
- Used in combination with the security keep SBS...
- Installation position on the drive side, horizontally at top or bottom
- Profile systems: currently suitable for Rehau Geneo and Brilliant Design; for use with other profile systems please contact your Winkhaus partner.

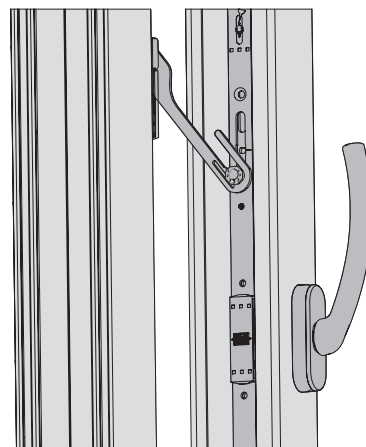
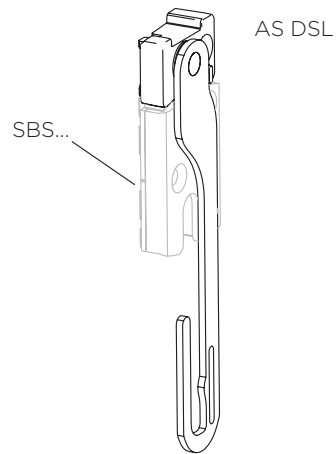

Item description	Item No.		VPA1 Qty./Type	VPA2 Qty./Type	VPA3 Qty./Type
AS DSL.60.LS	5056893	1	20 BL	100 KK	800 EK
AS DSL.60.RS	5056892	1	20 BL	100 KK	800 EK

RS = right, LS = left

General deployment instruction keeps

Description / Code / Schrauben



Keep / SBA... / 1



Pull-in device / ZV-RT / 2

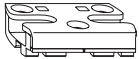

Security keep / SBS... / 3



Sash lifter / FH... / 2

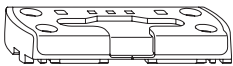

Security tilt keep / SBK... / 4

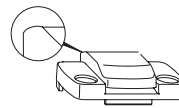

Sash lifter / FH.R. ... / 2
(Radius at rear edge)

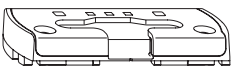

Security tilt keep / SBK... V
Screwed in the prechamber / 2



Sash lifter / FH.L. ... / 2
(Long version)

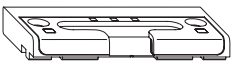

Security tilt keep / SBK... BS / 2
Ground sill

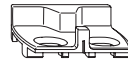

Mini vent keep / AS.SBA.K.T / 2



Keep for dual and triple function
element / SBA .. DFE-TFE / 1

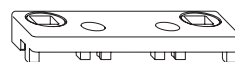

Run-up block / SA ... / 2

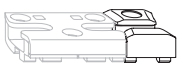

Tilt keep (tilt before turn) /
SBK...E / 1

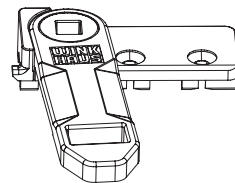

Mini vent keep / AS OF / 2

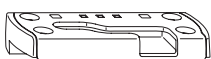

Security keep / SBS.K.PAD
(Parallel action / Tilt before Turn)

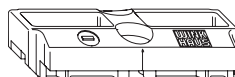

Run-up block / SA OF / 2

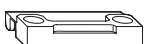









Adapter / FT WSK / 2

Aluplast

Ideal 2000 - 3000

NML 13 mm

UEB 20 mm







SBK 		SBS 		SBA 		AS SBA, ZV-RT, RT.MSL 	
SBK.K.61	2892209	SBS.K.61	2892129	SBA.K.61	2892073	AS SBA.K.T.13-3	4937780
SBK.K.61.V	2892170					RT.MSL.3	5007006
						ZV-RT 60 RC SL	2312155
SBK.K.E/PAD 		BK, FT 		FH 		SA, SA OF 	
SBK.K.E.3	4935945	BK 60 SL	1919553	FH.152	4949428	SA 152 SL	2366946
		BK 61 RC SL	5026717	FH.R.152	4995853	SA OF 61 SL	4940007
		FT WSK 61	1497653				

Aluplast

Ideal 4000 - 8000, Energeto

NML 13 mm

UEB 20 mm

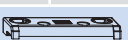
SBK 		SBS 		SBA 		AS SBA, ZV-RT, RT.MSL 	
SBK.K.161	2861621	SBS.K.161	2861672	SBA.K.161	2824071	AS SBA.K.T.13-5	4937782
SBK.K.161.V	4927435	SBS.K.161.M3	4927769	SBA.K.161.DFE-TFE.L.LS	4934013	RT.MSL.3	5007006
SBK.K.SP.161	5010275			SBA.K.161.DFE-TFE.L.RS	4934010	ZV-RT 161 RC SL	1213945
				SBA.K.161.DFE-TFE.LS	4935788		
				SBA.K.161.DFE-TFE.RS	4935789		
				SBA.K.161.S.40	5001559		
SBK.K.E/PAD 		BK, FT 		FH 		SA, SA OF 	
SBK.K.E.5	4935956	BK 61 RC SL	5026717	FH.161	4949431	SA 66 SL	2209887
SBS.K.PAD.161.LS	4995615	FT WSK 66	1530185	FH.R.161	4995855	SA OF 161 SL	5031823
SBS.K.PAD.161.RS	4995614						









11

Brüggmann / Salamander

System AD

NML 13 mm

UEB 20 mm









SBK 		SBS 		SBA 		AS SBA, ZV-RT, RT.MSL 	
SBK.K.94.P7	4927718	SBS.K.94.P7	4927717	SBA.K.94.P7	4927716	AS SBA.K.T.13-3	4937780
SBK.K.94.V.P7	4927719					RT.MSL.3	5007006
						ZV-RT 452/13 SL	2074732
SBK.K.E/PAD 		BK, FT 		FH 		SA, SA OF 	
SBK.K.E.3	4935945	BK 552 RC SL	2522321	FH.152	4949428	SA 152 SL	2366946
		FT WSK152	1787079	FH.R.152	4995853		

Brüggmann / Salamander

System MD

NML 13 mm

UEB 20 mm







SBK 		SBS 		SBA 		AS SBA, ZV-RT, RT.MSL 	
SBK.K.94.P7	4927718	SBS.K.94.P7	4927717	SBA.K.94.P7	4927716	AS SBA.K.T.13-3	4937780
SBK.K.94.V.P7	4927719					ZV-RT 452/13 SL	2074732
SBK.K.E/PAD 		BK, FT 		FH 		SA, SA OF 	
SBK.K.E.3	4935945	BK 552 RC SL	2522321	FH.152	4949428	SA 152 SL	2366946
		FT WSK152	1787079	FH.R.152	4995853		

Deceuninck

Zendow



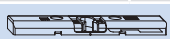

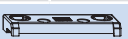

NML 13 mm

UEB 20 mm

SBK 		SBS 		SBA 		AS SBA, ZV-RT, RT.MSL 	
SBK.K.169	4926366	SBS.K.169	4926363	SBA.K.169	4926362	AS SBA.K.T.13-4	4937781
SBK.K.169.P7	4974642					RT.MSL.3	5007006
SBK.K.169/21.P7	5042728					ZV-RT 169 RC SL	5033656
SBK.K.SP.169.P7	5065629						
SBK.K.E/PAD 		BK, FT 		FH 		SA, SA OF 	
SBK.K.E.4	4935954	BKS 169 RC-V SL	2356852	FH.205	4949429	SA 169 SL	2359447
SBS.K.PAD.169.LS	4995621	FT WSK169	2356596	FH.L.205	5002710	SA OF 169 SL	5019156
SBS.K.PAD.169.RS	4995620			FH.R.205	4995854		



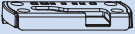

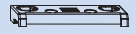



**Deceuninck
Zendow**

**NML 13 mm
UEB 20 mm**

SBK 		SBS 		SBA 		AS SBA, ZV-RT, RT.MSL 	
SBK.K.169	4926366	SBS.K.169	4926363	SBA.K.169	4926362	AS SBA.K.T.13-4	4937781
SBK.K.169.P7	4974642					RT.MSL.3	5007006
SBK.K.169/21.P7	5042728					ZV-RT 169 RC SL	5033656
SBK.K.SP.169.P7	5065629						
SBK.K.E/PAD 		BK, FT 		FH 		SA, SA OF 	
SBK.K.E.4	4935954	BKS 169 RC-V SL	2356852	FH.205	4949429	SA 169 SL	2359447
SBS.K.PAD.169.LS	4995621	FT WSK169	2356596	FH.L.205	5002710	SA OF 169 SL	5019156
SBS.K.PAD.169.RS	4995620			FH.R.205	4995854		







**Gealan
3000**

**NML 13 mm
UEB 20 mm**

SBK 		SBS 		SBA 		AS SBA, ZV-RT, RT.MSL 	
SBK.K.162	4929797	SBS.K.162	4929798	SBA.K.162	4929796	AS SBA.K.T.13-4	4937781
SBK.K.162.P7	4964887	SBS.K.162.M3	5040828	SBA.K.62	4926222	RT.MSL.3	5007006
SBK.K.162.S.P7	5056334	SBS.K.162.P7	4964886			ZV-RT 162 SL	2088350
SBK.K.162.V.P7	4964888	SBS.K.162.S.P7	5056333			ZV-RT 62 SL	2094258
SBK.K.62	4929831	SBS.K.169.P7	4974641				
SBK.K.E/PAD 		BK, FT 		FH 		SA, SA OF 	
SBK.K.E.4	4935954	BK 134 SL	2103935	FH.205	4949429	SA 62 SL6 SL	2749461
		BK 61 RC SL	5026717	FH.L.205	5002710		
		FT WSK 62	1348121	FH.R.205	4995854		





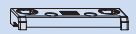

**Gealan
6000, 7000, 8000, 9000**

**NML 13 mm
UEB 20 mm**

SBK 		SBS 		SBA 		AS SBA, ZV-RT, RT.MSL 	
SBK.K.162	4929797	SBS.K.162	4929798	SBA.K.162	4929796	AS SBA.K.T.13-4	4937781
SBK.K.162.P7	4964887	SBS.K.162.M3	5040828			RT.MSL.3	5007006
SBK.K.162.S	4986548	SBS.K.162.P7	4964886			ZV-RT 162 SL	2088350
SBK.K.162.S.P7	5056334	SBS.K.162.S	4988102			ZV-RT 62 SL	2094258
SBK.K.162.V	4929799	SBS.K.162.S.P7	5056333				
SBK.K.162.V.P7	4964888						
SBK.K.SP.162	5030281						
SBK.K.E/PAD 		BK, FT 		FH 		SA, SA OF 	
SBK.K.E.4	4935954	BK 134 SL	2103935	FH.205	4949429	SA 62 SL6 SL	2749461
SBS.K.PAD.162.LS	4995617	FT WSK 62	1348121	FH.L.205	5002710		
SBS.K.PAD.162.RS	4995616			FH.R.205	4995854		

**Gealan
Kubus**

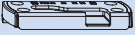
**NML 13 mm
UEB 20 mm**

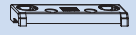





SBK 		SBS 		SBA 		AS SBA, ZV-RT, RT.MSL 	
SBK.K.262.P7	5050623	SBS.K.262.P7	5050622	SBA.K.562.P7 KT	5004126	ZV-RT 162 SL	2088350
SBK.K.E/PAD 		BK, FT 		FH 		SA, SA OF 	
		BK 134 SL	2103935				
		FT WSK162	1719578				

Inoutic

Arcade, Prestige, Deluxe, Elite, MD100, Eforte

NML 13 mm

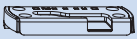
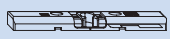
UEB 21 mm









SBK 		SBS 		SBA 		AS SBA, ZV-RT, RT.MSL 	
SBK.K.192	4932276	SBS.K.192	4932275	SBA.K.192	5002139	AS SBA.K.T.13-5	4937782
SBK.K.192.S12.ZN	4937573	SBS.K.192.S12.ZN	4937572	SBA.K.192.RWS	4932786	ZV-RT 192 RC SL	1261395
SBK.K.192.V	4932277			SBA.K.192.S12	4939192		
SBK.K.SP.192	5010276						
SBK.K.E/PAD 		BK, FT 		FH 		SA, SA OF 	
SBK.K.E.192	4942838	BK192 S12 RC	4939193	FH.192	4949434	SA 192 SL	1919932
SBS.K.PAD.192.LS	4995623			FH.L.192	5008876	SA OF 192 SL	4932035
SBS.K.PAD.192.RS	4995622			FH.R.192	4995858		

Internova

Internova 6000

NML 13 mm

UEB 20 mm









SBK 		SBS 		SBA 		AS SBA, ZV-RT, RT.MSL 	
SBK.K.16	4936032	SBS.K.16	4936031	SBA.K.16	4936437	AS SBA.K.T.13-3	4937780
						RT.MSL.3	5007006
SBK.K.E/PAD 		BK, FT 		FH 		SA, SA OF 	
SBK.K.E.3	4935945	BK SL	1793250	FH.152	4949428	SA SL	1895985
		FT WSK 76	1500787	FH.R.152	4995853		

KBE (Profine)

70 AD / 70 MD / 88+

NML 13 mm

UEB 20 mm







SBK 		SBS 		SBA 		AS SBA, ZV-RT, RT.MSL 	
SBK.K.205.P5	4996028	SBS.K.205	5039488	SBA.K.205.P5	2922210	AS SBA.K.T.13-4	4937781
SBK.K.205.S.P5	5046012	SBS.K.205.P5	4996029			RT.MSL.3	5007006
SBK.K.205.V.P5	4996027	SBS.K.205.S.P5	5046011			ZV-RT 169 RC SL	5033656
SBK.K.E/PAD 		BK, FT 		FH 		SA, SA OF 	
SBK.K.E.4	4935954	BKS 169 RC-V SL	2356852	FH.205	4949429	SA 169 SL	2359447
SBS.K.PAD.205.LS	4995625	FT WSK205	1809590	FH.L.205	5002710	SA OF 169 SL	5019156
SBS.K.PAD.205.RS	4995624			FH.R.205	4995854	SA SL	1895985

KBE (Profine)

76 AD, 76 MD

NML 13 mm

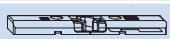
UEB 20 mm









SBK 		SBS 		SBA 		AS SBA, ZV-RT, RT.MSL 	
SBK.K.205.P5	4996028	SBS.K.205	5039488	SBA.K.205.P5	2922210	AS SBA.K.T.13-4	4937781
SBK.K.205.S.P5	5046012	SBS.K.205.P5	4996029			RT.MSL.3	5007006
SBK.K.205.V.P5	4996027	SBS.K.205.S.P5	5046011			ZV-RT 169 RC SL	5033656
SBK.K.E/PAD 		BK, FT 		FH 		SA, SA OF 	
SBK.K.E.4	4935954	BKS 169 RC-V SL	2356852	FH.205	4949429	SA 169 SL	2359447
SBS.K.PAD.205.LS	4995625	FT WSK205	1809590	FH.L.205	5002710	SA OF 169 SL	5019156
SBS.K.PAD.205.RS	4995624			FH.R.205	4995854	SA SL	1895985

Kömmerring (Profine)

76 AD, 76 MD

NML 13 mm

UEB 20 mm







SBK 		SBS 		SBA 		AS SBA, ZV-RT, RT.MSL 	
SBK.K.205.P5	4996028	SBS.K.205	5039488	SBA.K.205.P5	2922210	AS SBA.K.T.13-4	4937781
SBK.K.205.V.P5	4996027	SBS.K.205.P5	4996029			RT.MSL.3	5007006
		SBS.K.205.S.P5	5046011			ZV-RT 169 RC SL	5033656
SBK.K.E/PAD 		BK, FT 		FH 		SA, SA OF 	
SBK.K.E.4	4935954	BKS 169 RC-V SL	2356852	FH.205	4949429	SA 169 SL	2359447
SBS.K.PAD.205.LS	4995625	FT WSK205	1809590	FH.L.205	5002710	SA OF 169 SL	5019156
SBS.K.PAD.205.RS	4995624			FH.R.205	4995854		

Kömmerling (Profine)

Classic, Elegance, Avantgarde, 88+

NML 13 mm

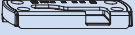
UEB 20 mm

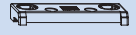







SBK 		SBS 		SBA 		AS SBA, ZV-RT, RT.MSL 	
SBK.K.144	5049010	SBS.K.144	2920661	SBA.K.144	2920652	AS SBA.K.T.13-5	4937782
SBK.K.144.S	2920687	SBS.K.144.M3	5013386	SBA.K.144.DFE-TFE.LS	4935785	RT.MSL.3	5007006
SBK.K.144.V	4927432	SBS.K.144.S	4969911	SBA.K.144.DFE-TFE.RS	4935786	ZV-RT 144 SL14	2020081
SBK.K.SP.144	5010272			SBA.K.144.V	4927431		
				SBA.K.244	4931453		
SBK.K.E/PAD 		BK, FT 		FH 		SA, SA OF 	
SBK.K.E.144	4995421	BK 144 SL	1919570	FH.144	4949433	SA 144 SL	2366911
SBS.K.PAD.144.LS	4995609	FT WSK144	1326221	FH.R.144	4995856	SA OF 144 SL	2859530
SBS.K.PAD.144.RS	4995608						

LB.Profile

PAD / PMD / PCD

NML 13 mm

UEB 20 mm







SBK 		SBS 		SBA 		AS SBA, ZV-RT, RT.MSL 	
SBK.K.12	4926374	SBS.K.12	4926373	SBA.K.12	4926372	AS SBA.K.T.13-3	4937780
SBK.K.12.V	4926375					RT.MSL.3	5007006
SBK.K.E/PAD 		BK, FT 		FH 		SA, SA OF 	
SBK.K.E.3	4935945	BK 60 SL	1919553	FH.152	4949428	SA SL	1895985
		FT WSK 76	1500787	FH.R.152	4995853		

Plustec

Plustec

NML 13 mm

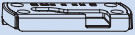
UEB 20 mm

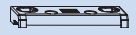







SBK 		SBS 		SBA 		AS SBA, ZV-RT, RT.MSL 	
SBK.K.76.M3	4926437	SBS.K.76.M3	4926436	SBA.K.76	4926432	AS SBA.K.T.13-4	4937781
SBK.K.76.V.M3	4926438					RT.MSL.3	5007006
						ZV-RT 169 RC SL	5033656
SBK.K.E/PAD 		BK, FT 		FH 		SA, SA OF 	
		BK 60 SL	1919553	FH.152	4949428	SA 60 SL	1929209
		BK 61 RC SL	5026717	FH.R.152	4995853		
		FT WSK 76	1500787				

Rehau

Geneo, Synego

NML 13 mm







UEB 20 mm

SBK 		SBS 		SBA 		AS SBA, ZV-RT, RT.MSL 	
SBK.K.160	4933118	SBS.K.160.S16.WK2	4941217	SBA.K.160	4933116	AS SBA.K.T.13-4	4937781
SBK.K.SP.60/260	5030280	SBS.K.160.WK2	4933803			RT.MSL.3	5007006
		SBS.K.60.M3	4927768			ZV-RT 160	4933117
SBK.K.E/PAD 		BK, FT 		FH 		SA, SA OF 	
SBK.K.E.4	4935954	BK 60 SL	1919553	FH.205	4949429	SA 60 SL	1929209
SBS.K.PAD.160.LS	4995613	FT WSK 60	1345393	FH.L.205	5002710		
SBS.K.PAD.160.RS	4995612			FH.R.205	4995854		

Rehau

S735, Brillant, Thermo-Design, Brillant-Design, Basic-Design

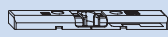





**NML 13 mm
UEB 20 mm**

SBK 		SBS 		SBA 		AS SBA, ZV-RT, RT.MSL 	
SBK.K.60	2861584	SBS.K.60	2861656	SBA.K.60	2824046	AS SBA.K.T.13-3	4937780
SBK.K.60.M3	4927850	SBS.K.60.M3	4927768	SBA.K.60 -0,3	4931375	RT.MSL.3	5007006
SBK.K.60.V	4927433					ZV-RT 60 SL	1975336
SBK.K.E/PAD 		BK, FT 		FH 		SA, SA OF 	
SBK.K.E.60	4942833	BK 60 SL	1919553	FH.60	4949432	SA 60 SL	1929209
		BK 61 RC SL	5026717	FH.R.60	4995857	SA OF 60 SL	2859521
		FT WSK 60	1345393				

Roplasto

7001 AD, 7001 MD

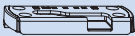

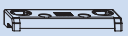



**NML 13 mm
UEB 22 mm**

SBK 		SBS 		SBA 		AS SBA, ZV-RT, RT.MSL 	
SBK.K.211	4931331	SBS.K.211	4931330	SBA.K.211	4931329	AS SBA.K.T.13-4	4937781
						RT.MSL.3	5007006
						ZV-RT 169 RC SL	5033656
SBK.K.E/PAD 		BK, FT 		FH 		SA, SA OF 	
SBK.K.E.4	4935954	BK SL	1793250	FH.205	4949429	SA 169 SL	2359447
		FT WSK205	1809590	FH.L.205	5002710	SA OF 169 SL	5019156
				FH.R.205	4995854	SA SL	1895985

Salamander

2D / 3D / MD / Streamline

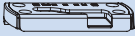
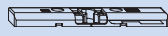

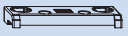



**NML 13 mm
UEB 20 mm**

SBK 		SBS 		SBA 		AS SBA, ZV-RT, RT.MSL 	
SBK.K.28	4926454	SBS.K.28	4926453	SBA.K.28	4926452	AS SBA.K.T.13-4	4937781
SBK.K.28.P5	5059940	SBS.K.28.P5	5059939	SBA.K.28.DFE-TFE. LS	4935783	RT.MSL.3	5007006
SBK.K.28.V	4926455			SBA.K.28.DFE-TFE. RS	4935784	ZV-RT 134 SL	2864478
SBK.K.SP.28	5031710			SBA.K.28.P5	5059941		
SBK.K.E/PAD 		BK, FT 		FH 		SA, SA OF 	
SBK.K.E.28	4942832	BK 134 SL	2103935	FH.144	4949433	SA 134 SL	2367181
SBS.K.PAD.28.LS	4995601	FT WSK134	1537651	FH.R.144	4995856		
SBS.K.PAD.28.RS	4995600						

Salamander



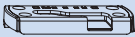
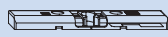



bluEvolution 82 / 92

**NML 13 mm
UEB 20 mm**

SBK 		SBS 		SBA 		AS SBA, ZV-RT, RT.MSL 	
SBK.K.128	4941002	SBS.K.128	4941001	SBA.K.28	4926452	AS SBA.K.T.13-4	4937781
SBK.K.128.V	4941004			SBA.K.28.DFE-TFE. LS	4935783	RT.MSL.3	5007006
				SBA.K.28.DFE-TFE. RS	4935784	ZV-RT 134 SL	2864478
				SBA.K.28.P5	5059941		
SBK.K.E/PAD 		BK, FT 		FH 		SA, SA OF 	
SBS.K.PAD.128.LS	4995607	BK 134 SL	2103935	FH.205	4949429	SA 134 SL	2367181
SBS.K.PAD.128.RS	4995606	FT WSK134	1537651	FH.L.205	5002710		
				FH.R.205	4995854		



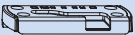

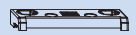

**Schüco
Corona 60**

**NML 13 mm
UEB 20 mm**

SBK 		SBS 		SBA 		AS SBA, ZV-RT, RT.MSL 	
SBK.K.66.P5	4936142	SBS.K.66.P5	4936140	SBA.K.166	4930272	AS SBA.K.T.13-5	4937782
SBK.K.66.P7	5027282			SBA.K.66	4932001	RT.MSL.3	5007006
SBK.K.66.V.P5	4936143					ZV-RT 60 SL	1975336
SBK.K.E/PAD 		BK, FT 		FH 		SA, SA OF 	
		BK 60 SL	1919553	FH.161	4949431	SA 66 SL	2209887
		BK 61 RC SL	5026717	FH.R.161	4995855	SA OF 60 SL	2859521
		FT WSK 61	1497653				
		FT WSK 66	1530185				



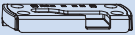

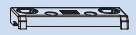



**Schüco
Corona 70 / Corona SI 82**

**NML 13 mm
UEB 20 mm**

SBK 		SBS 		SBA 		AS SBA, ZV-RT, RT.MSL 	
SBK.K.166	4930269	SBS.K.166	4930271	SBA.K.166	4930272	AS SBA.K.T.13-3	4937780
SBK.K.166.V	4930270					RT.MSL.3	5007006
SBK.K.SP.166	5018520					ZV-RT 60 SL	1975336
SBK.K.E/PAD 		BK, FT 		FH 		SA, SA OF 	
SBK.K.E.3	4935945	BK 60 SL	1919553	FH.152	4949428	SA 60 SL	1929209
SBS.K.PAD.166.LS	4995619	FT WSK 61	1497653	FH.R.152	4995853		
SBS.K.PAD.166.RS	4995618						

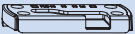





**Schüco
Living**

**NML 13 mm
UEB 20 mm**

SBK 		SBS 		SBA 		AS SBA, ZV-RT, RT.MSL 	
SBK.K.166	4930269	SBS.K.166	4930271	SBA.K.166	4930272	AS SBA.K.T.13-3	4937780
SBK.K.166.V	4930270					RT.MSL.3	5007006
						ZV-RT 60 SL	1975336
SBK.K.E/PAD 		BK, FT 		FH 		SA, SA OF 	
SBK.K.E.3	4935945	BK 60 SL	1919553	FH.152	4949428	SA 60 SL	1929209
SBS.K.PAD.166.LS	4995619	FT WSK 61	1497653	FH.R.152	4995853		
SBS.K.PAD.166.RS	4995618						

**Trocal (Profine)
76 AD, 76 MD**

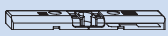
**NML 13 mm
UEB 20 mm**

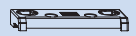
SBK 		SBS 		SBA 		AS SBA, ZV-RT, RT.MSL 	
SBK.K.205.P5	4996028	SBS.K.205	5039488	SBA.K.205.P5	2922210	AS SBA.K.T.13-4	4937781
SBK.K.205.S.P5	5046012	SBS.K.205.P5	4996029			RT.MSL.3	5007006
SBK.K.205.V.P5	4996027	SBS.K.205.S.P5	5046011			ZV-RT 169 RC SL	5033656
SBK.K.E/PAD 		BK, FT 		FH 		SA, SA OF 	
SBK.K.E.4	4935954	BKS 169 RC-V SL	2356852	FH.205	4949429	SA 169 SL	2359447
SBS.K.PAD.205.LS	4995625	FT WSK205	1809590	FH.L.205	5002710	SA OF 169 SL	5019156
SBS.K.PAD.205.RS	4995624			FH.R.205	4995854	SA SL	1895985

**Trocal (Profine)
InnoNova 2000 / 88+**

**NML 13 mm
UEB 20 mm**







SBK 		SBS 		SBA 		AS SBA, ZV-RT, RT.MSL 	
SBK.K.126.V.P3	4998434	SBS.K.126.ZN	4926198	SBA.K.126	4926196	ZV-RT 226 RC SL	2389494
SBK.K.E/PAD 		BK, FT 		FH 		SA, SA OF 	
		FT WSK 42	1320680			SA SL	1895985

Trocal (Profine)

InnoNova A5 / M5

NML 13 mm

UEB 20 mm

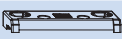





SBK 		SBS 		SBA 		AS SBA, ZV-RT, RT.MSL 	
SBK.K.226.P5	2921217	SBS.K.226.P5	2921137	SBA.K.226	2921090	AS SBA.K.T.13-3	4937780
SBK.K.226.V.P5	2921233					RT.MSL.3	5007006
SBK.K.E/PAD 		BK, FT 		FH 		SA, SA OF 	
SBK.K.E.3	4935945	BK 226 RC SL	2393055	FH.152	4949428	SA SL	1895985
SBS.K.PAD.226.LS	4995627			FH.R.152	4995853		
SBS.K.PAD.226.RS	4995626						

Veka

Softline 70 AD/MD, Topline AD, Softline 82 AD/MD, Artline

NML 13 mm

UEB 20 mm

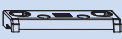





SBK 		SBS 		SBA 		AS SBA, ZV-RT, RT.MSL 	
SBK.K.152	4938546	SBS.K.152	4990061	SBA.K.152	5050727	AS SBA.K.T.13-3	4937780
SBK.K.152.P5	4939133	SBS.K.152.M3	4984031	SBA.K.152.DFE-TFE.LS	5050760	RT.MSL.3	5007006
SBK.K.152.V	4938547	SBS.K.152.P5	4938954	SBA.K.152.DFE-TFE.RS	5050729	ZV-RT 452/13 SL	2074732
SBK.K.152.V.P5	4939137	SBS.K152.S	4937038	SBA.K.152.P5.DFE-TFE.LS	4990374		
SBK.K.SP.152	5055019			SBA.K.152.P5.DFE-TFE.RS	4990373		
SBK.K.SP.152.P5	5055020			SBA.K.152+0,5	5050726		
				SBA.K.552+0,5	5050725		
SBK.K.E/PAD 		BK, FT 		FH 		SA, SA OF 	
SBK.K.E.3	4935945	BK 552 RC SL	2522321	FH.152	4949428	SA 152 SL	2366946
SBS.K.PAD.152.LS	4995611	FT WSK152	1787079	FH.R.152	4995853	SA OF 152 SL	2859505
SBS.K.PAD.152.RS	4995610						

Wymar

2500

NML 13 mm

UEB 20 mm

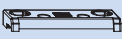





SBK 		SBS 		SBA 		AS SBA, ZV-RT, RT.MSL 	
SBK.K.14	4936198	SBS.K.14	4936197	SBA.K.14	4936196	AS SBA.K.T.13-3	4937780
						RT.MSL.3	5007006
						ZV-RT 162 SL	2088350
SBK.K.E/PAD 		BK, FT 		FH 		SA, SA OF 	
		BK 552 RC SL	2522321	FH.152	4949428	SA 62 SL6 SL	2749461
		FT WSK 61	1497653	FH.R.152	4995853		

Wymar

3000

NML 13 mm

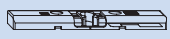
UEB 20 mm

SBK 		SBS 		SBA 		AS SBA, ZV-RT, RT.MSL 	
SBK.K.114	4936246	SBS.K.114	4936244	SBA.K.114	4936243	AS SBA.K.T.13-5	4937782
						RT.MSL.3	5007006
						ZV-RT 162 SL	2088350
SBK.K.E/PAD 		BK, FT 		FH 		SA, SA OF 	
		FT WSK 66	1530185	FH.161	4949431	SA 62 SL6 SL	2749461
				FH.R.161	4995855		

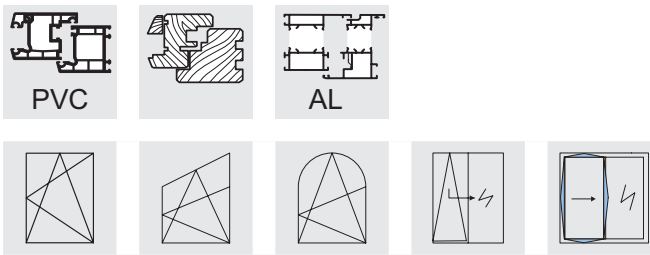

Punches for window fittings

Punch BST AP/FS

- Used to cut fitting elements
- Punch including footswitch
- Pedal operated
- Can be used together with fitting ruler
- Required operating pressure 6 bar

Ruler LIN AP/FS

- Dimensional positioning of the fitting elements to be cut
- Cutting of both central and constant parts

Fitting punch, lever AP.HH

- Used to cut fitting elements
- Manual operation
- Serves as repair punch – not suitable for permanent use

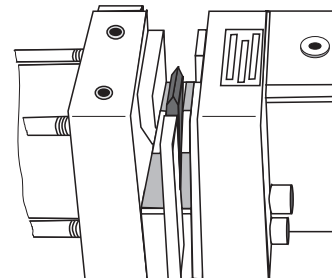

BST AP/FS

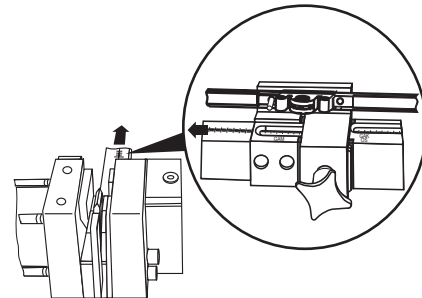

LIN AP/FS

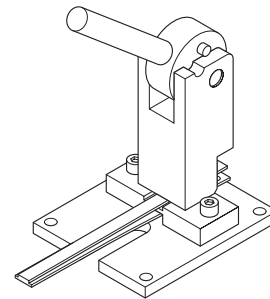

AP.HH

Item description	Item No.	VPA1 Qty./Type	VPA2 Qty./Type
BST AP/FS	1466339	1 GK	12 EK
LIN AP/FS LS	1466321	20 L2	
AP.HH	4970430	1 KT	48 EA

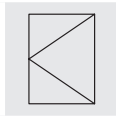
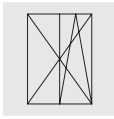
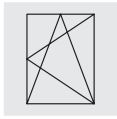
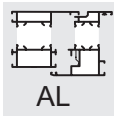
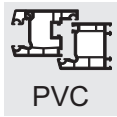

Drilling jig LE.B.EL-SL.K

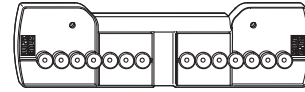

- Drilling jig to drill the pilot holes for corner and shear hinges
- Overlap dimension adjustable from 18 to 22 mm
- Preadjusted to a defined dimension

LE.B.EL-SL.K.3-3

- For hinge with 3 mm pin

LE.B.EL-SL.K.BR

- For 130 kg hinge

Item description	Item No.	Overlap
LE.B.EL-SL.K-18	4966329	18
LE.B.EL-SL.K-20	4966340	20
LE.B.EL-SL.K-21	4966341	21
LE.B.EL-SL.K-22	4966342	22
LE.B.EL.SL.K. 3-3-18	4966343	18
LE.B.EL.SL.K. 3-3-20	4966345	20
LE.B.EL.SL.K. 3-3-21	4966346	21
LE.B.EL.SL.K. 3-3-22	4966347	22
LE.B.EL.SL.K. BR-18	4966348	18
LE.B.EL.SL.K. BR-20	4966350	20
LE.B.EL.SL.K. BR-21	4966351	21
LE.B.EL.SL.K. BR-22	4966352	22

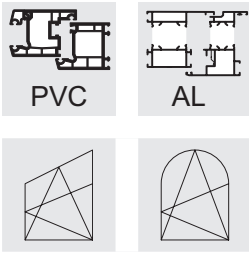

Drilling jig studio shear LE.B.SW-A

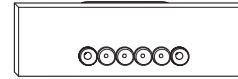

Drilling jig studio shear LE.B.SW-A

- For studio windows
- Drilling jig to make pilot holes
- Fixed overlap dimension

Drilling jig round arch LE.B.SWR

- (without figure)

Item description	Item No.	Overlap
LE.B.SW-A 18.3-3	4978111	18
LE.B.SW-A 18.6-3	4978097	18
LE.B.SW-A 20.3-3	4978112	20
LE.B.SW-A 20.6-3	4978098	20
LE.B.SW-A 22.6-3	4978110	22
LE.B.SWR	1467446	-

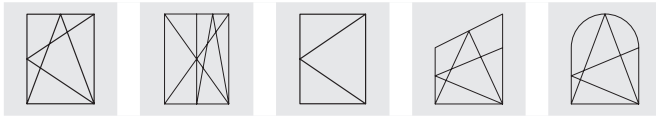
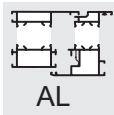
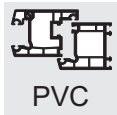

Jigs

- Used to position keeps in frame rebate
- Can be used left and right hand
- How to use please see mounting instructions

Different models:

- LE.N.K jig, constant handle position
- LE.N.T jig, central handle position (telescopic jig), locking drive GAM
- LE.N.T.ST jig, central handle position (telescopic jig), double-sash windows
- LE.N.T.GAVM jig, central handle position (telescopic jig), locking drive GAVM

Positioning aid LE.SB.N

- Serves the purpose of positioning the locking keeps within the frame rebate
- Can be used left and right hand
- Especially used for special window shapes (round or sloping head windows)
- How to use please see mounting instructions

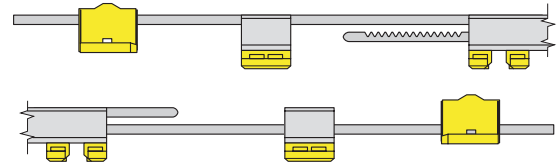

Item description	Item No.
LE.N.T.GAVM 300	4936773
LE.N.T.GAVM 420	4937047
LE.N.T.GAVM 620	4937061
LE.N.T.GAVM 920	4937063
LE.N.T.GAVM 1320	4937064
LE.N.T.GAVM 1850	4937065
LE.N.T.ST.0550-1200	4926548
LE.N.T.ST.1201-2170	4926549
LE.N.K.0290-0709	4926540
LE.N.K.0710-1100	4926541
LE.N.K.1101-1550	4926542
LE.N.K.1551-2225	4926543
LE.N.K.2225-4	4941065
LE.N.T.0710-1050	4926545
LE.N.T.1051-1800	4926546
LE.N.T.1801-2300	4926547
LE.SB.N	5039041

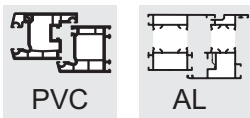

Drilling jig – Sash hinges LE.B. FL.K

- For sash hinges FL.K and FL.KB (except for FL.K...130)
- Drilling jig to pre-drill holes for sash hinge
- Fixed overlap dimension
- Fixed groove central position

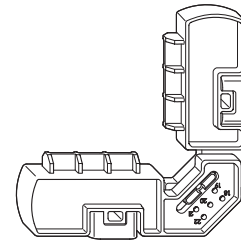

Drilling jig sash hinge LE.B.FL.FK

- For sash hinge FL.K...130
- Drilling jig to pre-drill holes for sash hinge
- Fixed overlap dimension
- Fixed groove central position

Item description	Item No.	Overlap	Groove centre position
LE.B.FL.K 20-9	4977449	20	9
LE.B.FL.K 21-9	4977450	21	9
LE.B.FL.FK 20-9	4977453	20	9
LE.B.FL.K 20-13	4926550	20	13
LE.B.FL.K 21-13	4940819	21	13
LE.B.FL.K 22-13	4977452	22	13
LE.B.FL.FK 20-13	4933842	20	13
LE.B.FL.FK 21-13	4940818	21	13
LE.B.FL.FK 22-13	4977456	22	13

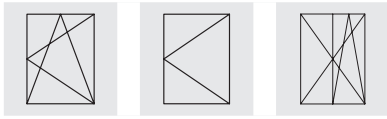
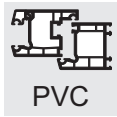

Various jigs

LE.N.T.SBS.K.160 WK2

- Jig for positioning SBS.K.160 WK2, central handle position (telescopic jig)

LE.N.K.SBS.160 WK2

- Jig for positioning SBS.K.160 WK2, constant handle position

LE.N.T.ST.SBS.K160WK2

- Jig for positioning SBS.K.160.WK2 on double-sash windows, central handle position

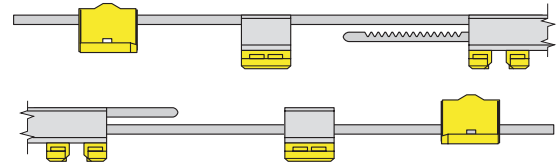

Item description	Item No.	Scope of application
LE.N.T.SBS.K.160 WK2 0710-1050	4952611	710 - 1050
LE.N.T.SBS.K.160 WK2 1051-1801	4952615	1051 - 1801
LE.N.T.SBS.K.160 WK2 1801-2300	4952617	1801 - 2300
LE.N.K.SBS.160 WK2 0209-0709	4952620	209 - 709
LE.N.K.SBS.160 WK2 0710-1100	4952622	710 - 1100
LE.N.K.SBS.160 WK2 1101-1550	4952623	1101 - 1550
LE.N.K.SBS.160 WK2 1551-2225	4952624	1551 - 2225
LE.N.K.SBS.160 WK2 2225-4	4952625	1975 - 2225
LE.N.T.ST.SBS.160WK2 550-1200	4952626	550 - 1200
LE.N.T.ST.SBS.160WK2 1201-2170	4952627	1201 - 2170

		Page	
13	Mounting Instructions	169 - 212	13
13.1	Notes on these assembly instructions	170	13.1
13.2	Shortening the fittings	171 - 174	13.2
13.3	Mounting of turn-tilt fittings	175 - 191	13.3
13.4	Mounting of studio fittings	192 - 199	13.4
13.5	Mounting of round-arch fittings	200 - 209	13.5
13.6	Function test / Operation	210 - 211	13.6
13.7	Mounting of accessories	212	13.7

Notes on these assembly instructions

Prerequisites

The mounting instructions are designed for mounting Winkhaus activPilot fittings for windows and glazed doors only. Fittings are designed for the following sash rebate sizes and sash weights:

- Min. sash rebate height 270 mm (see also Group 1)
- Max. sash rebate width 1725 mm
- From 1475 mm sash rebate width with additional shear ZSR
- Min. sash rebate height 230 mm
- Max. sash rebate height 2,800 mm
- Max. sash size 3 m²
- Max. sash weight 100/130 kg
- (1 mm glass thickness = 2.5 kg / m²)
- Ratio between sash rebate width : sash rebate height $\leq 2:1$



Note: In order to ascertain the permissible sash sizes and sash weights, please refer to the diagrams in the chapter "General Product Information".

Observe instructions on window profile

You must specifically take into account information provided by the profile manufacturer or system owner when determining the maximum sash sizes and sash weights!

Persons involved in mounting fittings must have read and understood this fitting guide. For all work with fittings, always follow Winkhaus' Product Liability Information. The manufacturer will accept no liability in case of failure to comply with this guide, deployment of insufficiently qualified staff and unauthorised alterations.

The respective fitting may only consist of the original Winkhaus proPilot fitting parts. We do not assume any liability in case third-party or non-approved system components are used.

Standard profile dimensions

See figure: Profile cross-section

The fitting is suitable for all PVC-U windows with standard fitting groove (eurogroove position 9 or 13 mm) and designed for an airgap of 12 mm and overlaps of 18 to 22 mm.

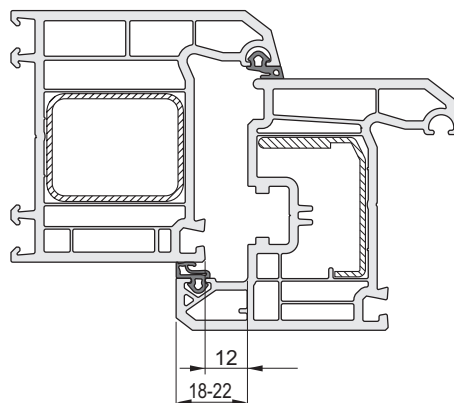

Profile cross-section

Please observe screwing advice!



Important: The load-bearing fitting components, such as corner, shear and sash hinges, must be designed according to the TBDK guidelines. Please adapt the drill diameter of the fixing screws, the screw diameter and the screw length to the load situation.



Important: Frame and hinge parts in water-bearing profile levels must be screwed in a way to avoid water entering into profile levels that cannot be drained afterwards. Please observe the information given by your system supplier.



Attention! Winkhaus does not provide fastening screws for fittings assembly. Always use fastening screws suitable for the window type and window dimensions.

Shortening the fittings

A detailed description on shortening of fittings is available here. This description will be referred to in these assembly instructions.

See figure: Fittings prior to punching

- Always insert the face plate (1) and drive rod (2) perpendicularly from the top with the face plate (1) pointing to the pressure cylinder.

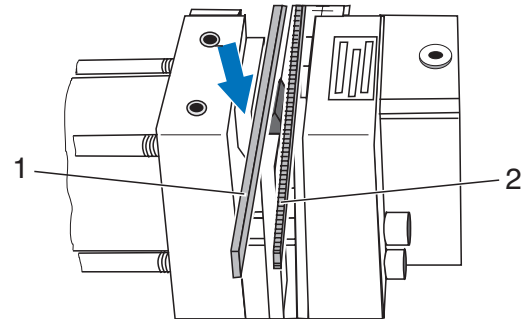

Fittings prior to punching

See figure: Fittings after punching

- After punching, always remove the face plate (1) and drive rod (2) perpendicularly in an upwards direction.

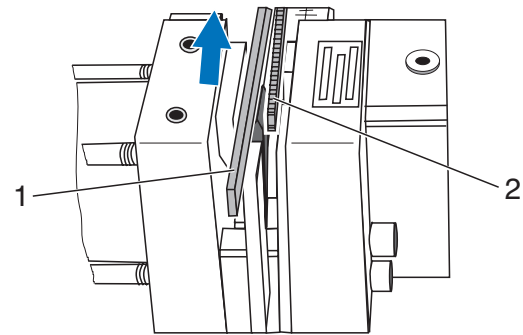

Fittings after punching

See figure: Cleaning the supporting surfaces

- Keep the supporting surfaces (3 and 4) clean.

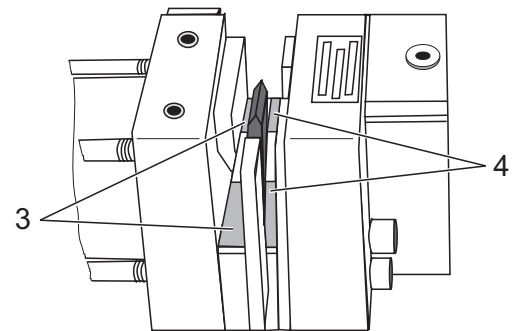

Cleaning the supporting surfaces

Shorten the drive rod GAM (central handle position)

See figure: Marking GAM

- Set measuring value FFH on the measuring device to the GAM mark.



Attention! If the GAM scale is displaced by one submarking, this corresponds to a longitudinal shift of 2 mm.

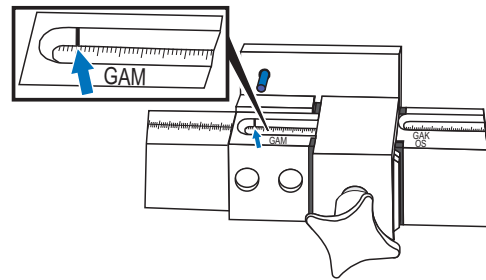

Marking GAM

See figure: Position for shortening drive rod

- Position the GAM drive rod at the scale; slot drill hole (2) onto bolt (1).
- Turn the GAM drive rod around, and slot the drill hole (3) onto the bolt (1), then trim the other side.
- Shorten the drive rod using the fitting punch.

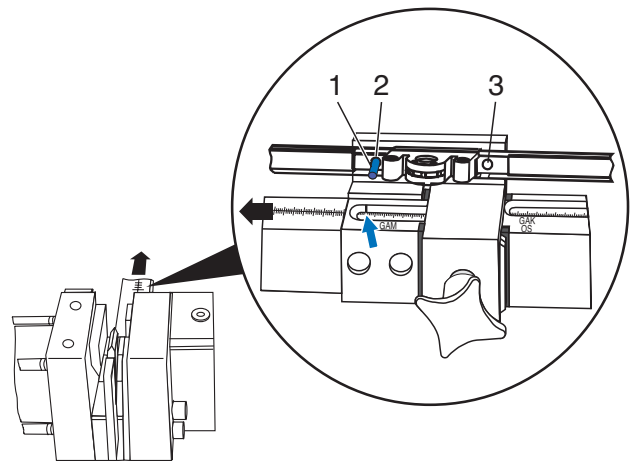

Position for shortening drive rod

Cutting of double sash drive rods GASM

GASM.800

See figure: Cutting instructions GASM

- Adjust the ruler to FFH + 400 mm (example: measured FFH = 567; adjust ruler to 567mm + 400 mm = 967 mm).
- Connect the drive to the marked hole on the ruler (arrows pointing to cutter).
- Cut off the element.

GASM.1050 - GASM.2300

See figure: Cutting instructions GASM

- Adjust the ruler to FFH (sash rebate height).
- Connect the drive to the marked hole on the ruler (arrows pointing to cutter).
- In case of GASM.1050 please make sure that the bolt in the elongated hole is positioned as indicated (red arrow).
- Cut off the element.
- GASM.1050 is always used in combination with corner drive E3.



Note: The double-sash drive rod must be trimmed before delivery.

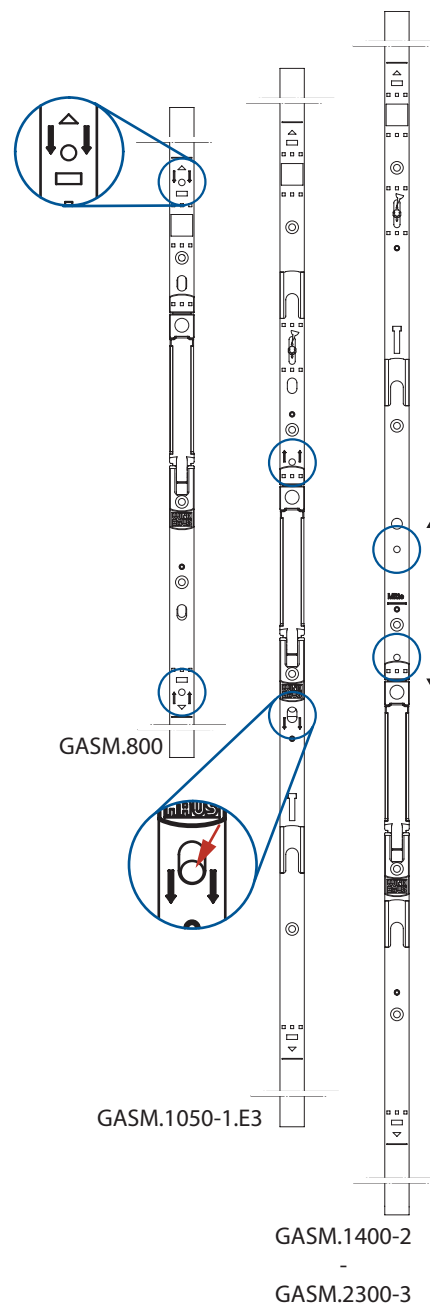

Cutting instructions GASM

Shorten the GAK / GASK drive rod (constant handle position) and top rod OS

i Note: The double-sash drive rod must be trimmed before delivery.

See figure: Markings GAK and OS

- Set the measuring value FFH (GAK/GASK) or FFB (OS) on the measuring device to the GAK/OS mark.

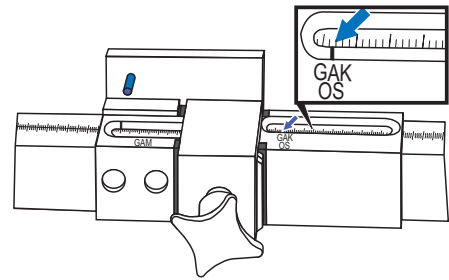

Markings GAK and OS

See figure: Position for shortening drive rod and/or top rod

- Cutting the top rod OS...
- Position the drive rod GAK/GASK (fixed handle position) (1) or the top rod OS (1) at the bolt (2).
- Shorten the drive rod (1) or the top rod (1).

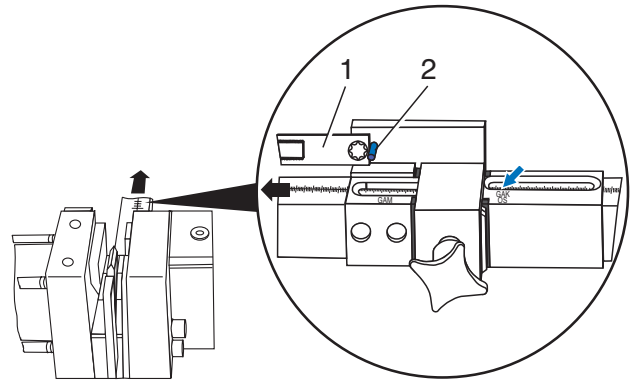

Position for shortening drive rod and/or top rod

Only applies to top rod OS1.600 (OS1.PA.600/OS.XL):

See figure: Position for shortening top rod

- Position the top rod (1) with square holes at bolt (2). Press the offset (see arrow) against the bolt (2).
- Shorten the top rod (1).

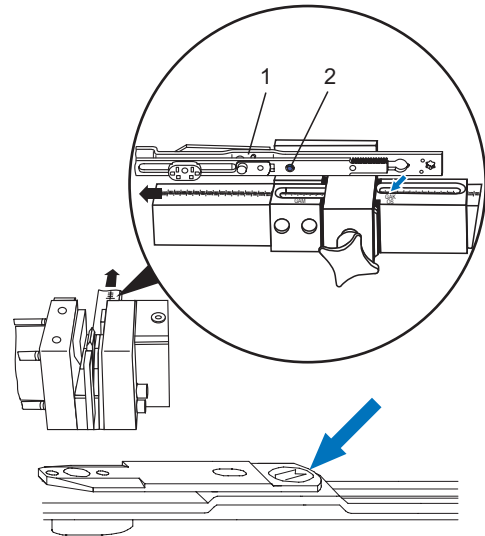

Position for shortening top rod

Mounting of fittings on sash

Turn-tilt type – Rectangular window

Prepare the window for fitting. Then proceed as follows:

i Please note: The following figures refer to a window for right-hand use. When fitting a window for left-hand use, the figures will be mirror-inverted.

The following also applies:

- When viewing the window from the inside, the symbol is depicted as a full line.
- When viewing the window from the outside, the symbol is depicted as a dotted line.

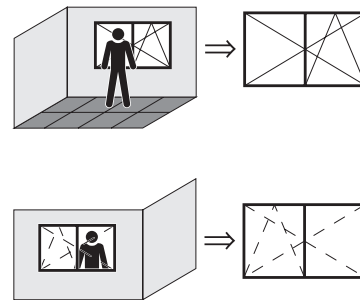

Determine the handle height:

Handle height for drive rod GAM

See figure: Sash rebate height FFH with central handle height GM

If you use a GAM drive rod ... (central handle position), the dimension GM is half the sash rebate height FFH.

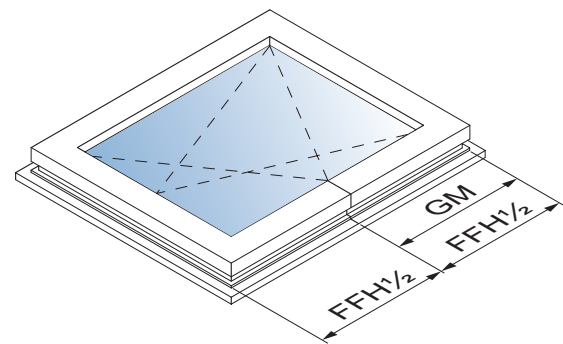

Sash rebate height FFH with central handle height GM

Handle height for drive rod GAK

See figure: Sash rebate height FFH with constant handle position GK

If you use a GAK drive rod ... (constant handle position), dimension GK changes to reflect the sash rebate height FFH. The exact dimensions are specified in the following table.

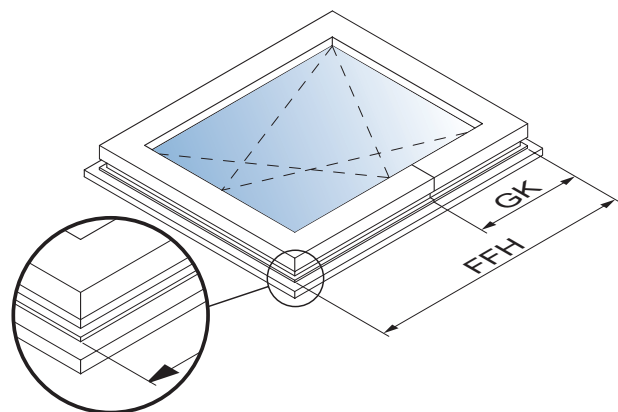

Sash rebate height FFH with constant handle position GK

See figure: Synoptical table: sash rebate height (FFH) / handle position (GK)

The table on the right gives a survey on the handle height (GK) of GAK with regard to the sash rebate height (FFH).

FFH	GK
230 – 324	GK = 114 *
325 – 420	GK = 114 *
421 – 460	GK = 210
461 – 700	GK = 210
701 – 850	GK = 260
851 – 1100	GK = 375
1101 – 1325	GK = 550
1326 – 1525	GK = 550
1526 – 1775	GK = 550
1776 – 2000	GK = 1050
2001 – 2225	GK = 1050

Synoptical table: sash rebate height (FFH) / handle position (GK)
* Requires the use of E3 corner drive

See figure: Scale drawing “Gear lock”

- Drill holes for gear case (ø 12 mm) as per scale drawing.

Mill the gear housing from the rebate side.

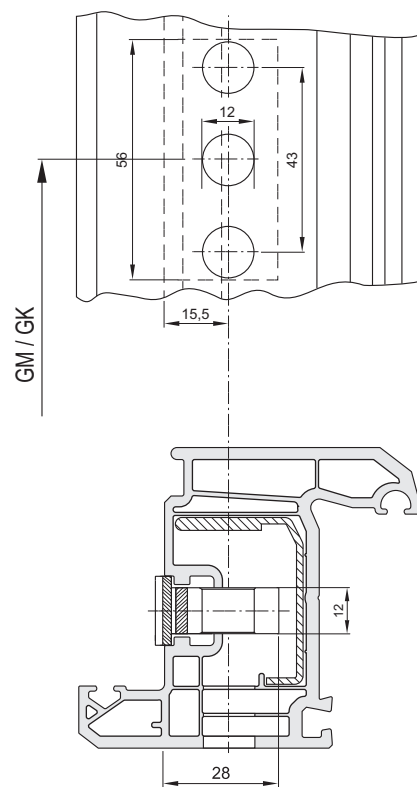

Scale drawing “Gear lock”

See figure: Corner drive E1

- Mounting of interlocking rods:
 - Fit the corner drive (2) into the fitting groove at the top of the sash so that the octagonal bolt is on the top side.
 - Fit the corner drive (1) into the fitting groove at the bottom of the sash so that the octagonal bolt is on the underside.
 - Fix both corner drives (1, 2) on the drive side with a single screw each.
 - Measure the sash rebate height (FFH).

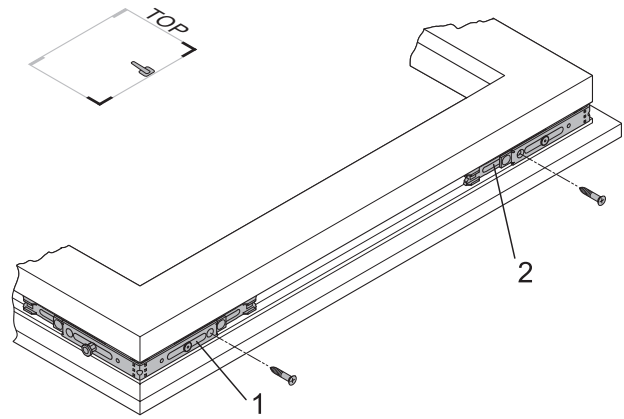

Corner drive E1

See figure: Drive rod GAM/GAK

- Cut the drive rod according to the instructions.
- Mount the drive rod:
 - Abut the drive rod (2) flush against the corner drive (3).
 - Allow the teeth on the drive rod to click into position on the gear rack on the corner drive.
 - Clip the drive rod into the corner drive (1) in the same way.
 - Press the drive rod into the eurogroove.
 - Screw the drive rod from the bottom up.

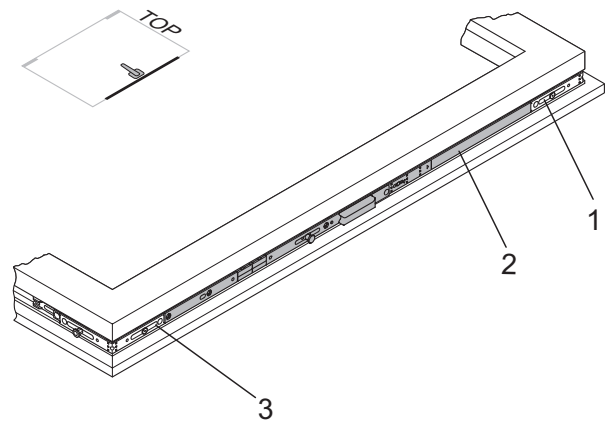

Drive rod GAM/GAK



Remark: Please make sure that the installation position of the drive rod is correct!

See figure: Corner drive E2

- Mounting of E2 corner drive:
 - Fit the corner drive (1) into the fitting groove at the top of the sash so that the octagonal bolt is on the hinge side.
 - Fasten the corner drive on the sash using a screw (2).
 - Measure the sash rebate width (FFB).



Please note: If you use an OS1.600 top rod, replace corner drive E2 with corner drive E3.

- Cut the top rod (see chapter 'Shortening the fittings').



Please note: For FFH < approx. 600 mm (depending on profile), place tilt limiter on top rod OS... (2).

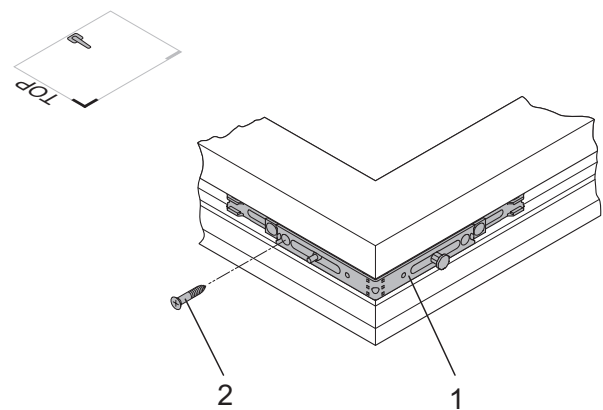

Corner drive E2

See figure: Top rod OS

- Insert the top rod and screw into position.
- Fit the top rod flush against the corner drive (1).
- Allow the gear teeth to click into place on the rack in the corner drive.
- Clip the top rod into the corner drive (3) in the same way.
- Press the top rod into the fitting groove.
- Screw the top rod from the hinge side to the drive side.

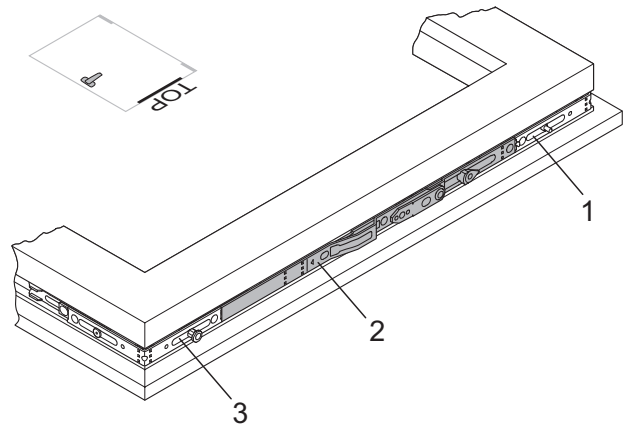

Top rod OS

See figure: Shears

- Mounting the shear:
 - Swivel out the hold-up shore (2) (see arrow).
 - Clip shear into the top rod (3) using mushroom bolt (4).
 - Press the shear bolt (5) into the spring on the hold-up shore.
 - Swivel the hold-up shore and shear to home position.
 - Press the shear onto the bolt (1).



Warning! Risk of Injury. The sash can fall out and cause injuries if the shear and top rod are not securely fastened.

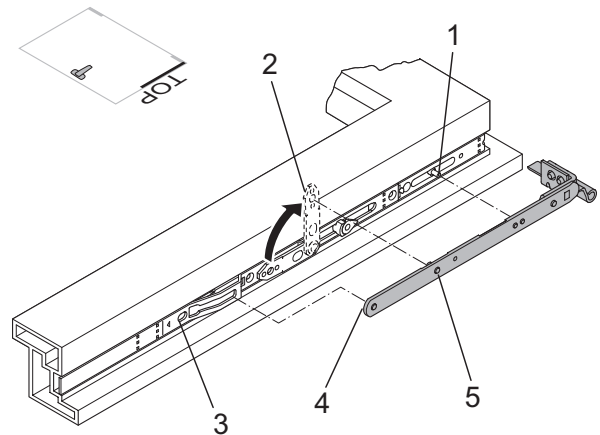

Shears

See figure: Interlocking rod M/MK (hinge side)

- Install Interlocking Rod on the hinge side.
- Fit the interlocking rod (1) flush against the corner drive (2).
- Click the interlocking rod gears into the teeth of the corner drive.
- Press the interlocking rod into the fitting groove.
- Screw the interlocking rod from the top down.
- Tighten the screw (3) fully to release the central fastening.



Please note: For a sash rebate height (FFH) and/or sash rebate width (FFB) of approx 800 mm (depending on the profile) an interlocking rod should also be fitted hinge-side and/or horizontally at the bottom / top.



Attention! Damage to fittings. If the central fastening is not released, the gearing cannot be actuated. Use of force will lead to torsion of the fittings. Always insert the screw fully up to the stop.

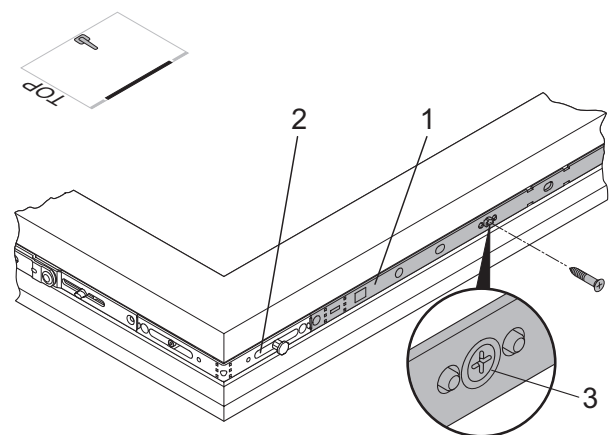

Interlocking rod M/MK (hinge side)

See figure: Corner drive E1

- Screw the corner drive (1) in place.



Please note: The following step is not needed, if you do not fit an interlocking rod to the corner drive.

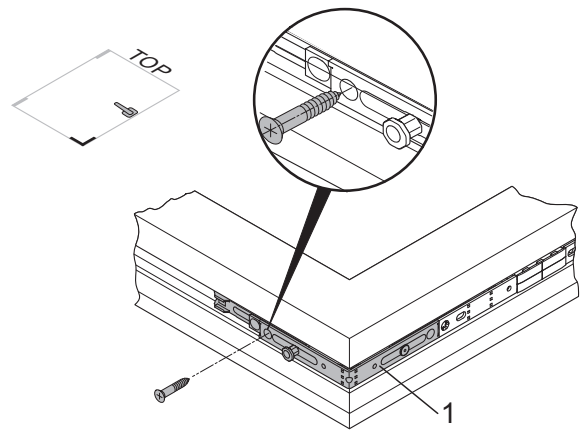

Corner drive E1

See figure: Interlocking rod M/MK (horizontal)

- Mount interlocking rod on the underside:
 - Abut the interlocking rod (2) flush against the corner drive (1).
 - Click the interlocking rod gears into the teeth of the corner drive.
 - Press the interlocking rod into the fitting groove.
 - Screw the interlocking rod from the corner drive to the centre of the window.
 - Tighten the screw (3) fully to release the central fastening.



Attention! Damage to fittings. If the central fastening is not released, the gearing cannot be actuated. Use of force will lead to torsion of the fittings. Always insert the screw fully up to the stop.

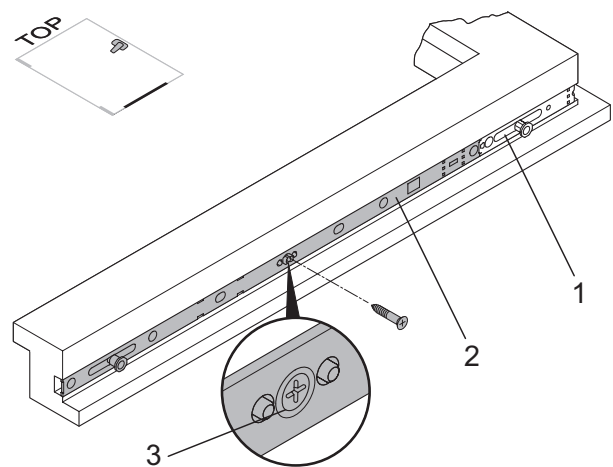

Interlocking rod M/MK (horizontal)

See figure: Sash hinge FL... / Mounting jig LE.B.FL...

- Fitting the sash hinge:
 - Position the mounting jig (1), clamp into the fitting groove and drill \varnothing 6 mm holes for the hinge plugs.
 - Pre-drill the screw holes through the first wall.
 - Insert the sash hinge (2) and fix it in place.
 - Make sure the sash hinge is fitted correctly into position.



Attention! Check if all screws are fixed into place on the fitting parts.

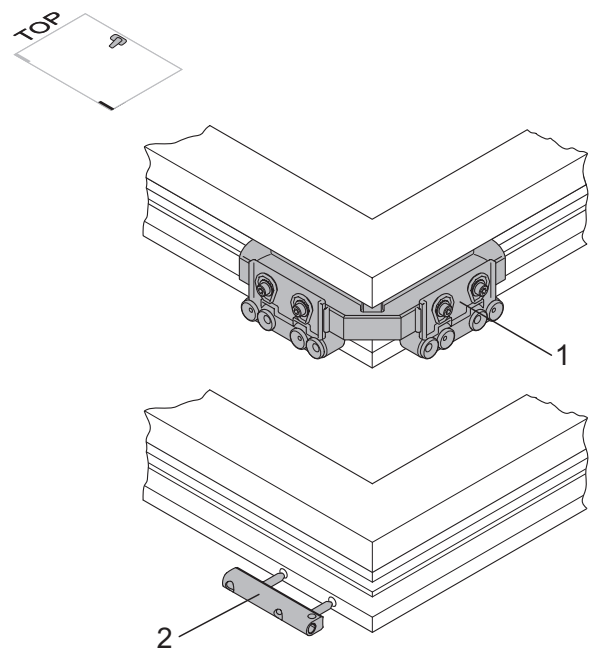

Sash hinge FL... / Mounting jig LE.B.FL...

Turn double sash type – Rectangular window



Please note: The following figures refer to a window for left-hand use. When fitting a window for right hand use, the figures will be mirror-inverted.

See figure: Corner drive E1

- Mounting of interlocking rods:
 - Fit the corner drive (2) into the fitting groove at the top of the sash so that the octagonal bolt is on the top side.
 - Fit the corner drive (1) into the fitting groove at the bottom of the sash so that the octagonal bolt is on the underside.
 - Fix both corner drives (1, 2) on the drive side with a single screw each.
 - Measure the sash rebate height (FFH).

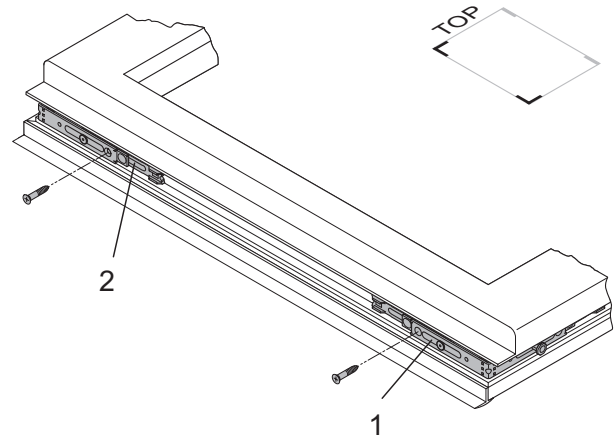

Corner drives E1

- Shorten the drive rod:
 - Shorten drive rod GASM or drive rod GASK in line with description "Shortening the fittings".



Please note: Make sure you shorten the drive rod in closed state (as delivered).

See figure: Drive rod GASM/GASK

- Mount the drive rod:
 - Abut the drive rod (2) flush against the corner drive (3).
 - Allow the teeth on the drive rod to click into position on the gear rack on the corner drive.
 - Clip the drive rod into the corner drive (1) in the same way.
 - Press the drive rod into the eurogroove.
 - Screw the drive rod from the bottom up.

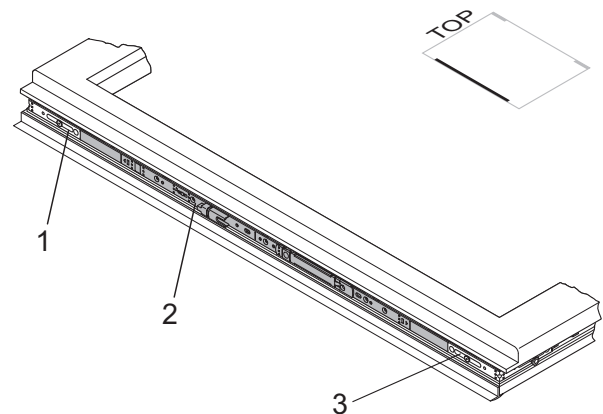

Drive rod GASM/GASK



Please note: To keep a neutral position, do not perform a function test until all fittings are in place.

See figure: Turn hinge bracket ERW/Turn hinge DL

- Mount the top hinge bracket and top hinge:
 - Fit the turn hinge bracket (1) into the eurogroove at the top of the sash so that the connecting bolt is on the top side.
 - Make sure the turn hinge bracket is flush.
 - Screw the turn hinge bracket onto the sash.
 - Insert the turn hinge (2) into the turn hinge bracket (1).

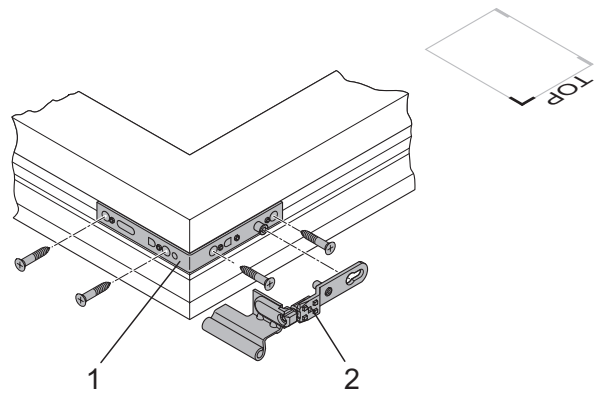

Turn hinge bracket ERW/Turn hinge DL



Please note: For a sash rebate height (FFH) and/or sash rebate width (FFB) of approx 800 mm (depending on the profile) an interlocking rod should also be fitted hinge-side and/or horizontally at the bottom / top. Observe the profile system supplier's processing guidelines in this respect.

See figure: Interlocking rod M (top)

- Mount the interlocking rod on the top side:
 - Fit the interlocking rod (1) flush against the corner drive (2).
 - Click the interlocking rod gears into the teeth of the corner drive.
 - Press the interlocking rod into the fitting groove.
 - Screw the interlocking rod tight from the hinge side to the gear side.
 - Tighten the screw (3) fully to release the central fastening.

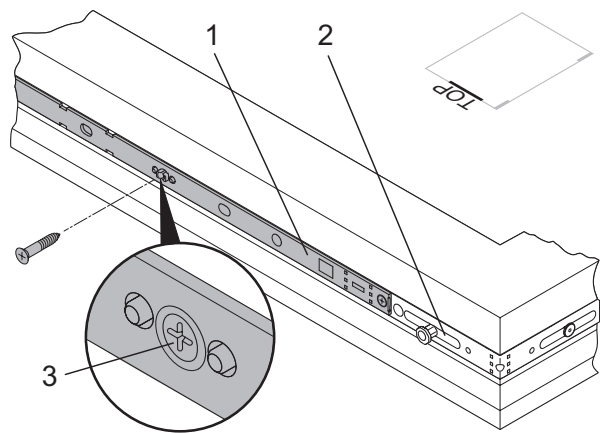

Interlocking rod M (top)



Attention! Damage to fittings. If the central fastening is not released, the gearing cannot be actuated. Use of force will lead to torsion of the fittings. Always insert the screw fully up to the stop.

See figure: Interlocking rod M (bottom)

- Mount interlocking rod on the underside:
 - See above

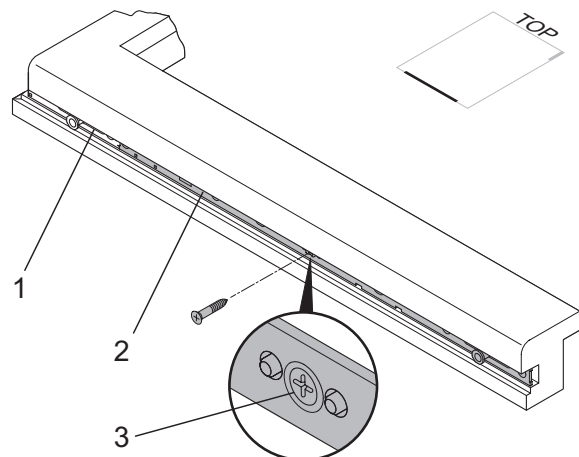

Interlocking rod M (bottom)

See figure: Pull-in device ZV-FT (hinge side)

- Position the pull-in device (1):
- S (ZV-FT) = sash rebate edge to centre of keep ZV-FT
- Press the pull-in device into the eurogroove and screw in place.

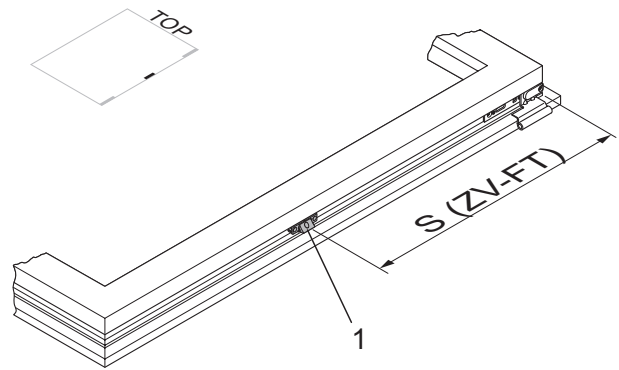

Pull-in device ZV-FT (hinge side)

See figure: Sash hinge FL... / Mounting jig LE.B.FL...

- Fitting the sash hinge:
- Position the mounting jig (1), clamp into the fitting groove and drill \varnothing 6 mm holes for the hinge plugs.
- Pre-drill the screw holes through the first wall.
- Insert the sash hinge (2) and fix it in place.
- Make sure the sash hinge is fitted correctly into position.

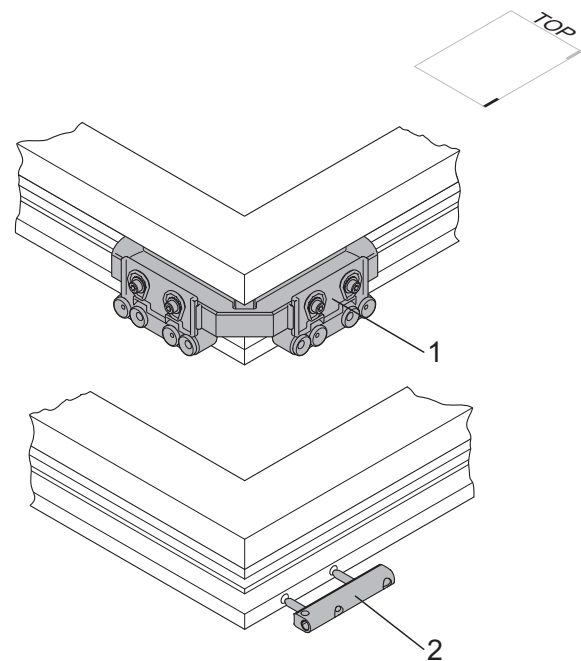

Sash hinge FL... / Mounting jig LE.B.FL...

Mounting of fittings on the window frame

Turn-tilt type – Rectangular window

See figure: Holes for corner and shear hinges

- Pre-drill the holes for shear and corner hinges and pre-drill the pin positions with \varnothing 6 mm.
- Use the template (1) to drill holes for corner hinge (3) and shear hinge (2). Distance between drill holes for shear and corner hinges is the same.



Note: Fit the shear and corner hinges after fitting the keeps!



Important: The load-bearing fitting components, such as corner, shear and sash hinges, must be designed according to the TBDK guidelines. Please adapt the drill diameter of the fixing screws, the screw diameter and the screw length to the load situation.

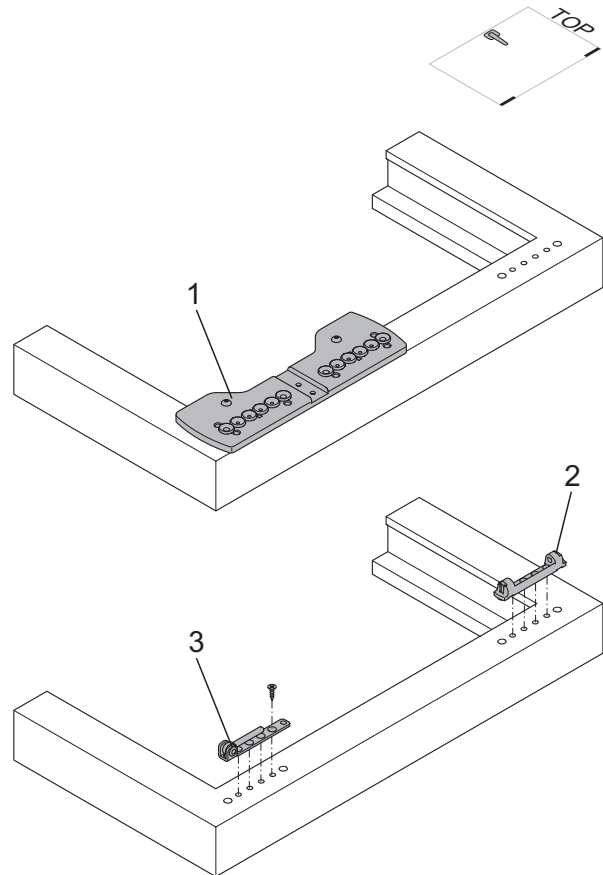

Holes for corner and shear hinges

Turn-tilt window

The illustration GAM.../GAK... shows the keep positions for backsets D15.5, D7.5 and D25-50. They also apply to GAMA/GAKA drive rods.

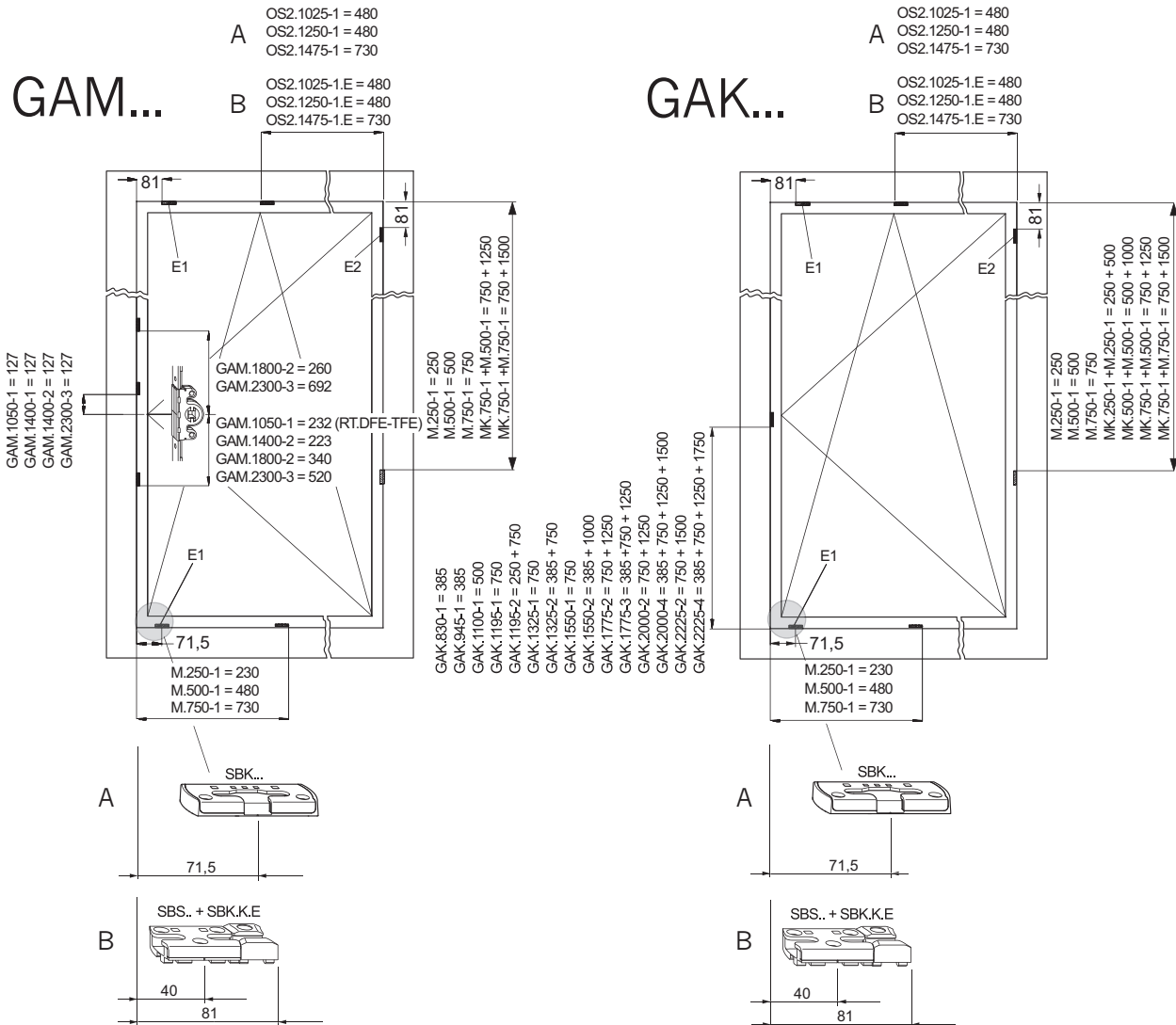

A = standard operating sequence turn tilt
B = operating sequence tilt before turn

Turn double sash type

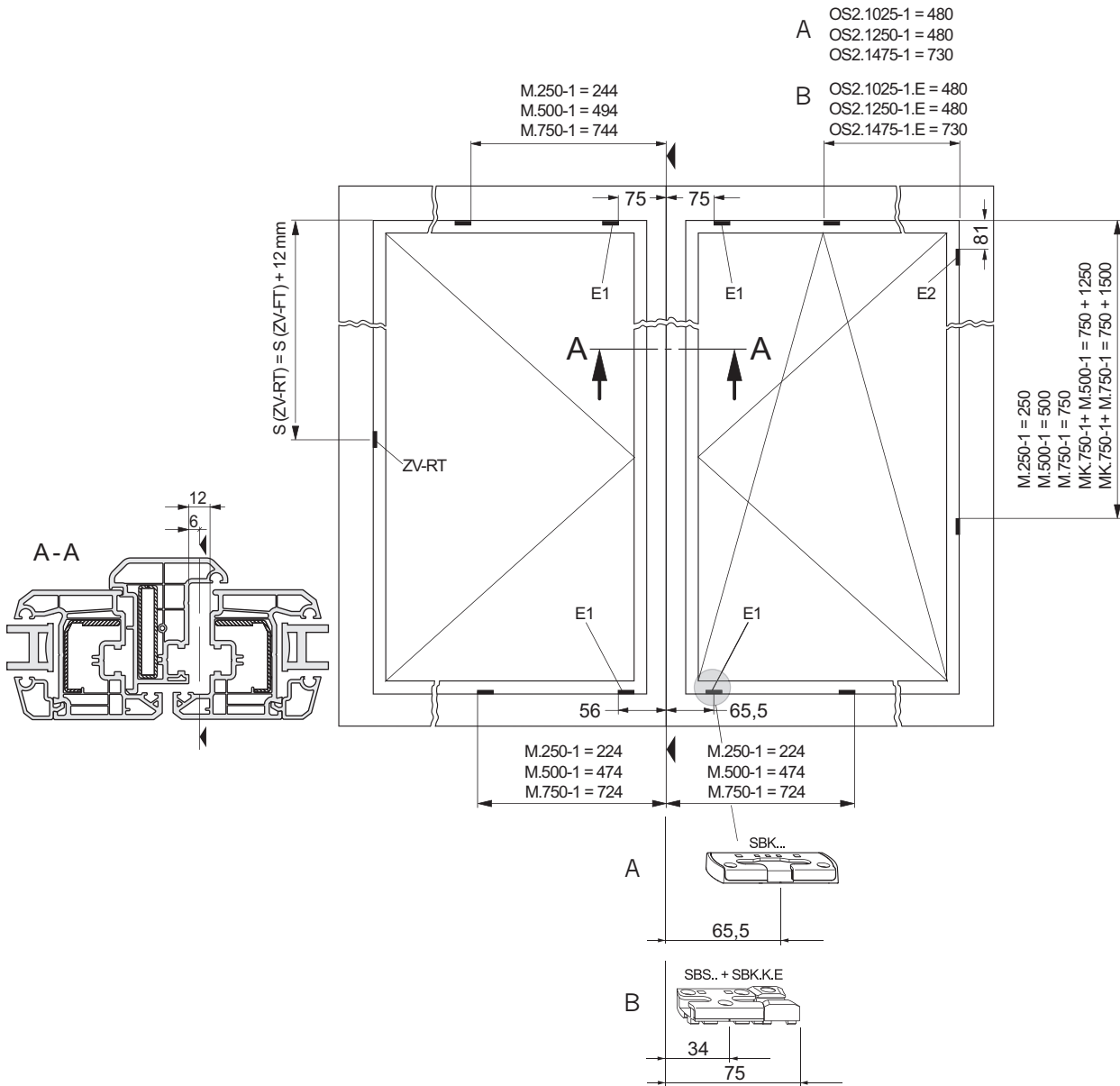

Keep positions, double sash window D/DK
 A = standard operating sequence turn tilt
 B = operating sequence tilt before turn
 S (ZV-FT) = sash rebate edge to centre of keep ZV-FT
 S (ZV-RT) = frame rebate edge to centre of pull-in device ZV-FT

Turn double sash type with D-6 drives

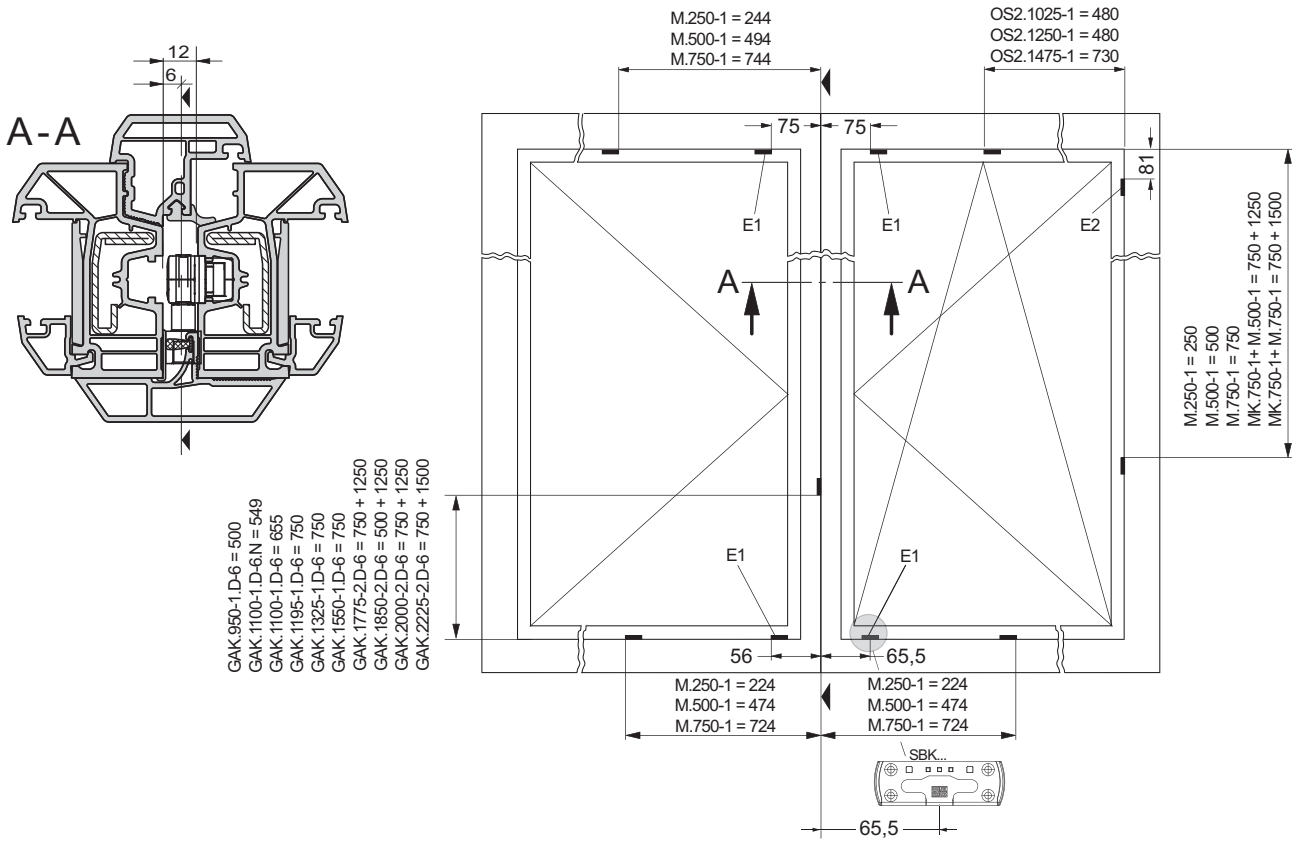

Keep positions of double-sash window (turn/turn-tilt) with D-6 drive

Turn type window with GAVM

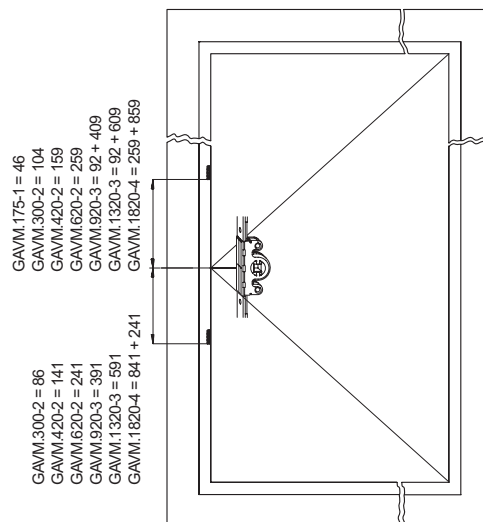





Keep positions turn window with drive rod GAVM

Fitting the keeps

Handling of mounting jigs is explained by reference to the L.E.N.K. 710-1100 mounting jig in the following. Other mounting jigs are handled in the same way. To position keeps, place the mounting jig on the frame rebate edge.

Labelling of mounting jigs

	Horizontal attachment = red element (for top rod and interlocking rod)
	Vertical attachment = yellow element (for drive rods and interlocking rods)
	Vertical / horizontal attachment = blue element (for corner drives)
	= Keep run-in

Keep top horizontal

- Align the mounting jig with the yellow element in the top corner.
- Place the SBA keep on the blue element labelled "E1" and "E2".

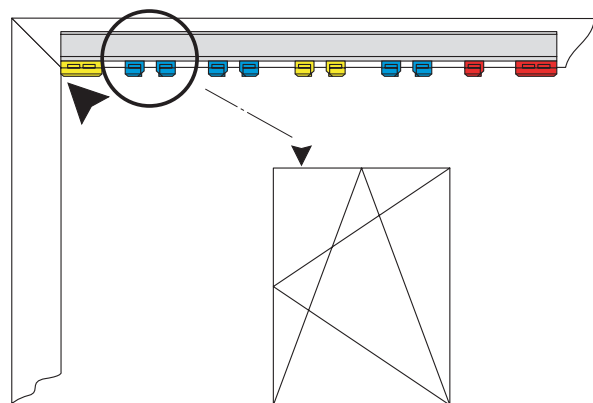

Keep top horizontal

Keep for top rod OS...

- Align the mounting jig with the red element in the top corner.
- Place the keep SBA on the blue element labelled "OS. ...".

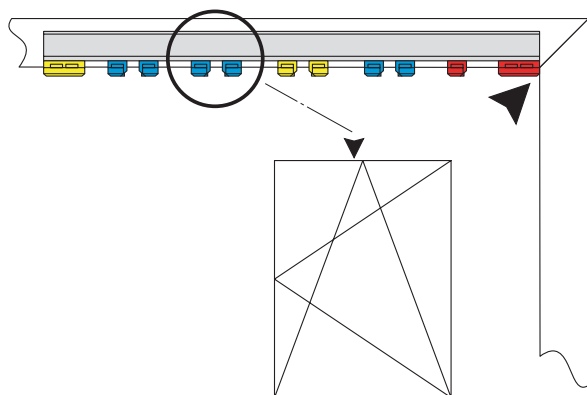

Keep for top rod OS...

Keeps hinge side

- Align the mounting jig with the yellow element in the top corner.
- Position the keep for the corner drive on the blue element.
- Position the keep for interlocking rod on the yellow element.



Note: The markings on the interlocking rod must match the marking on the yellow element.

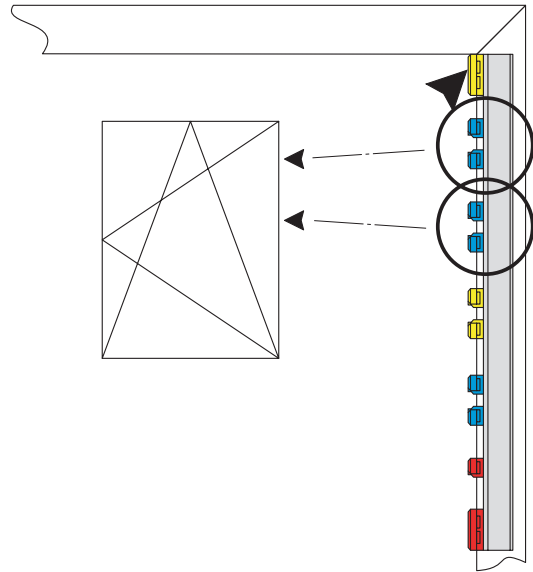

Keeps hinge side

Tilt keep SBK... bottom horizontal

- Align the mounting jig with the red element in the lower corner.
- Place the SBK... keep on the red element marked "Kippblech SBK".

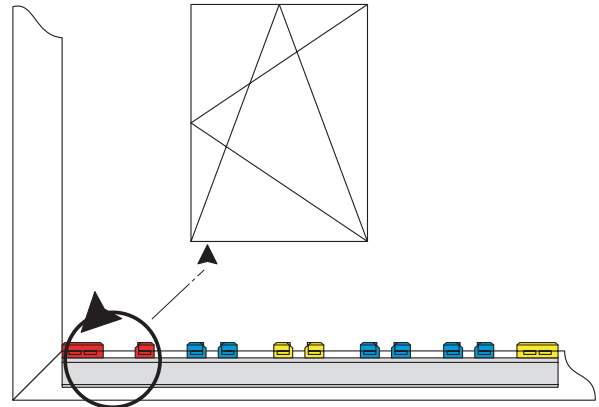

Tilt keep SBK... bottom horizontal

Interlocking Rod M..., bottom, horizontal

See figure: M bottom horizontal

- Align the mounting jig with the red element in the lower corner.
- Position the keep on the blue element marked "M" or "MK".

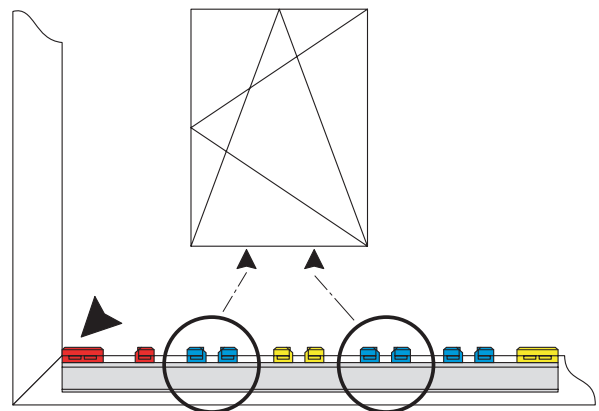

M bottom horizontal

13.3

Keeps SBA... for vertical GAK

- Align the mounting jig with the yellow element in the bottom corner.
- Place the SBA. ... keeps on the yellow and blue elements marked "GAK. ...".

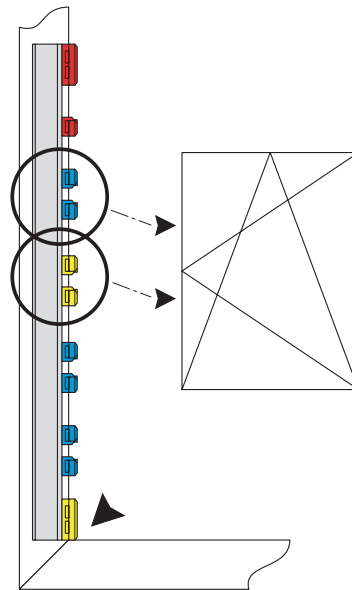

SBA... for vertical GAK

Keeps for GAM

- Attach the corresponding mounting jig labelled "top" or "bottom".
- Fit keeps in line with the labelling on the mounting template.

There are three telescopic jigs depending on the window height:

- LE.N.T. 0710-1050 for drive rod GAM 1050-1
- LE.N.T. 1051-1800 for drive rod GAM 1400-1/2 / 1800-2
- LE.N.T. 1801-2300 for drive rod GAM 2300-3

i Please note: The labelling on the drive rod must match the labelling on the yellow templates.

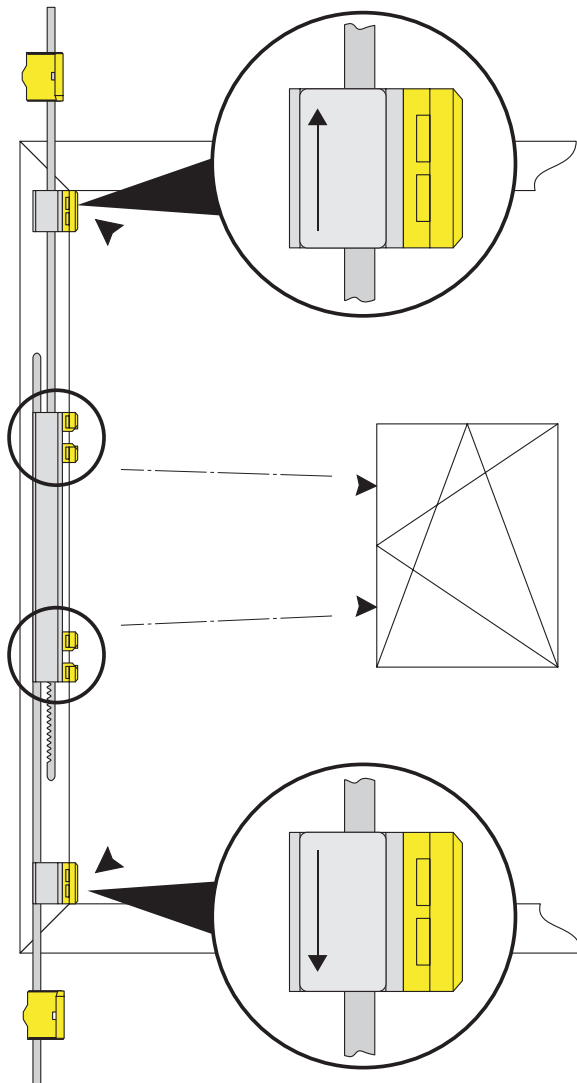

Keeps for GAM

Mounting shear and corner hinges

See figure: Shear and corner hinges

- Fix the shear hinge (2) and corner hinge (1) with screws.



Please note: Window builders must ensure that hinges and their anchorings are designed to support the expected loads and are professionally mounted.



Important: The load-bearing fitting components, such as corner, shear and sash hinges, must be designed according to the TDK guidelines. Please adapt the drill diameter of the fixing screws, the screw diameter and the screw length to the load situation.

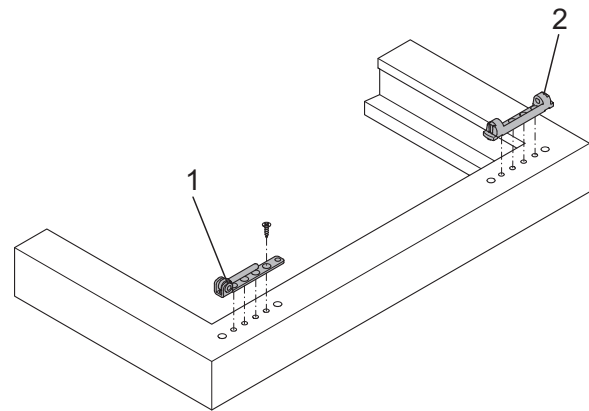

Shear and corner hinges

Fitting the sash

- Mount the sash, adjust for a good seal and fit the pin to secure against the shear hinge.
- Push all end caps and sealing caps onto the shear and corner hinges.

i Note: Insert pin from bottom (see arrow).

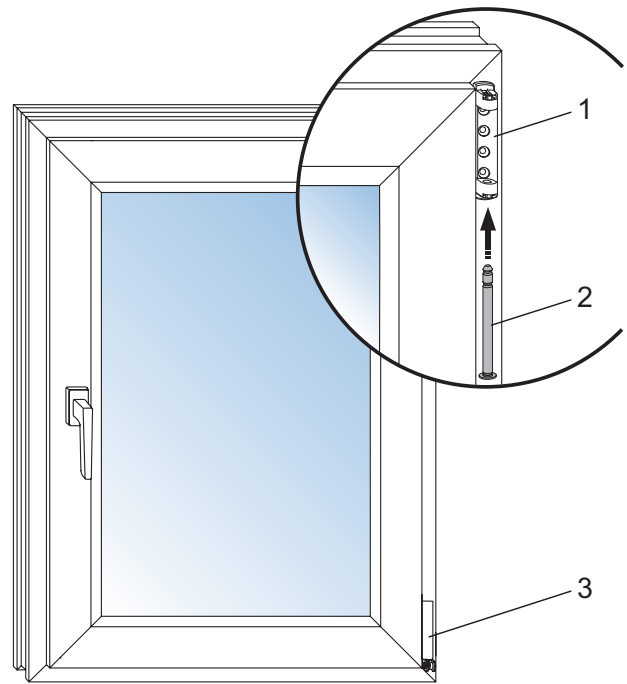

Shear and corner hinge

Removal of the sash

- Close the sash.
- Release the pin from the shear hinge.
- Remove the sash.

! Attention! Damage to shear hinge. In case of improper use and if you attempt to drive out the pin forcibly, the shear hinge will be damaged. Use only a screwdriver to release the pin as shown in the figure.

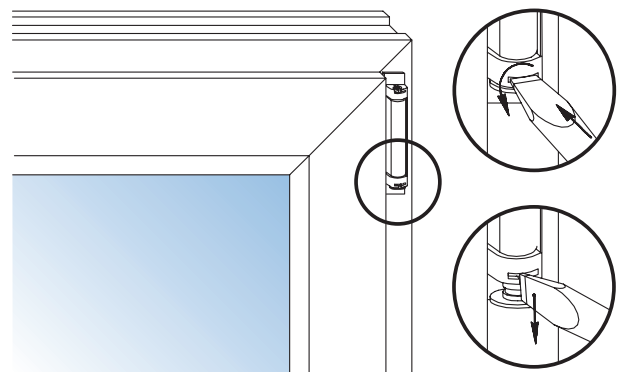

Release the pin in the shear hinge

Support the sash!

! In order to save the sash hinge and corner hinge from damage, sagging of the sash during assembly must be prevented (give horizontal support)!

! Caution: Secure the window sash from falling. Take the heavy sash weight into account!

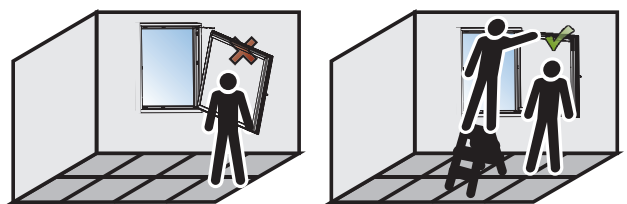

Mounting of fittings on sash

Turn-tilt type – studio window

Prepare the window for fitting. Then proceed as follows:



Please note: The following figures refer to a window for right-hand use. When fitting a window for left-hand use, the figures will be mirror-inverted.

The following also applies:

- When viewing the window from the inside, the symbol is depicted as a full line.
- When viewing the window from the outside, the symbol is depicted as a dotted line.

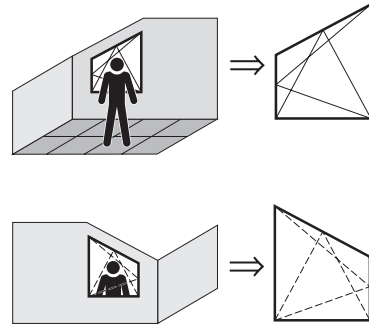

Studio variants

Studio components can be used for window elements with the following frame geometry.

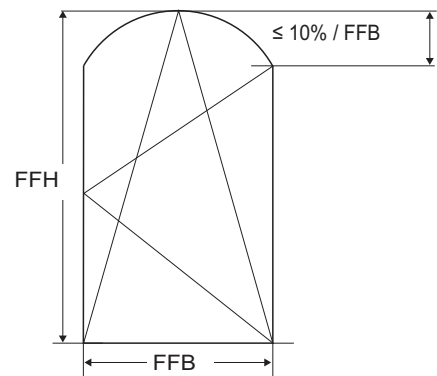
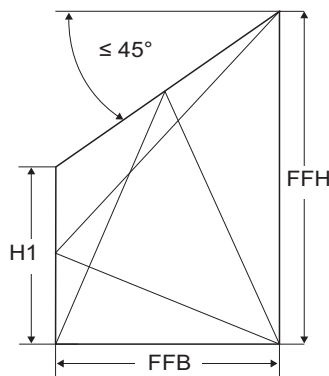
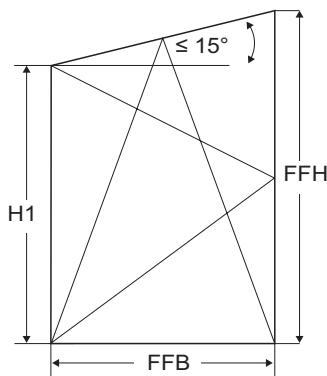

13.4

Determine the handle height:

Handle height for drive rod GAM

See figure: Sash rebate height FFH with central handle height GM

If you use a GAM drive rod ... (central handle position), the dimension GM is half the sash rebate height FFH.

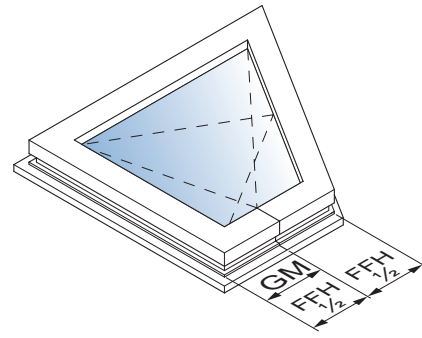

Sash rebate height FFH with central handle height GM

Handle height for drive rod GAK

If you use a GAK drive rod ... (constant handle position), dimension GK changes to reflect the sash rebate height FFH. The exact dimensions are specified in the following table.

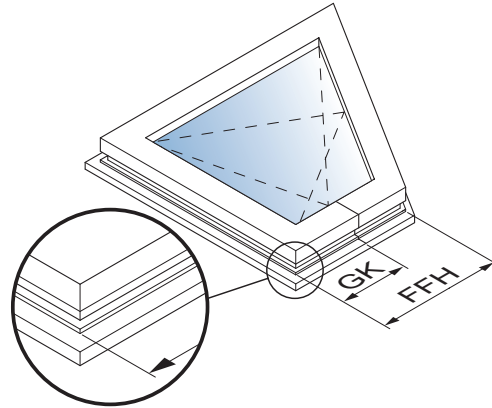

Sash rebate height FFH with constant handle position GK

See figure: Synoptical table: sash rebate height (FFH) / handle position (GK)

The table on the right gives a survey on the handle height (GK) of GAK with regard to the sash rebate height (FFH).

FFH	GK
230 – 324	GK = 114 *
325 – 420	GK = 114 *
421 – 460	GK = 210
461 – 700	GK = 210
701 – 850	GK = 260
851 – 1100	GK = 375
1101 – 1325	GK = 550
1326 – 1525	GK = 550
1526 – 1775	GK = 550
1776 – 2000	GK = 1050
2001 – 2225	GK = 1050

Synoptical table: sash rebate height (FFH) / handle position (GK)
* Requires the use of E3 corner drive

See figure: Scale drawing "Gear lock"

- Mill the gear housing from the rebate side.
- Drill holes for gear case (ø 12 mm) as per scale drawing.

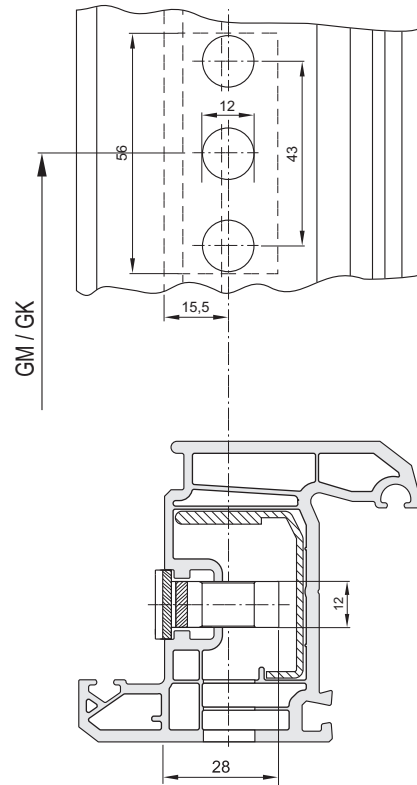

Scale drawing "Gear lock"

See figure: Corner drives E1 (1), E1.A (2)

- Mounting of interlocking rods:
 - Fit the corner drive (2) into the fitting groove at the top of the sash so that the octagonal bolt is on the top side.
 - Prior to insertion, bend the corner drive E1.A to rectangular shape.
 - Fit the corner drive (1) into the fitting groove at the bottom of the sash so that the octagonal bolt is on the underside.
 - Fix both corner drives (1, 2) on the drive side with a single screw each.

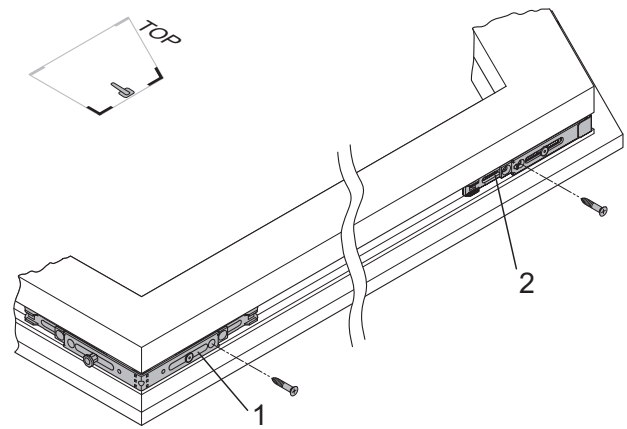

Corner drives E1 (1), E1.A (2)

13.4

See figure: Drive rod GAM/GAK

- Mount the drive rod:
 - Press the drive rod into the eurogroove.
 - Fit the handle to position the drive rod.
 - Mark the length of the drive rod on the flush edges of the corner drives.
 - Remove the handle and take the drive rod out of the fitting groove.
 - Mark and trim the drive rod using a punching press.
 - Mount the drive rod:
 - Abut the drive rod (3) flush against the corner drive (1).
 - Allow the teeth on the drive rod to click into position on the gear rack on the corner drive.
 - Clip the drive rod into the corner drive (4) in the same

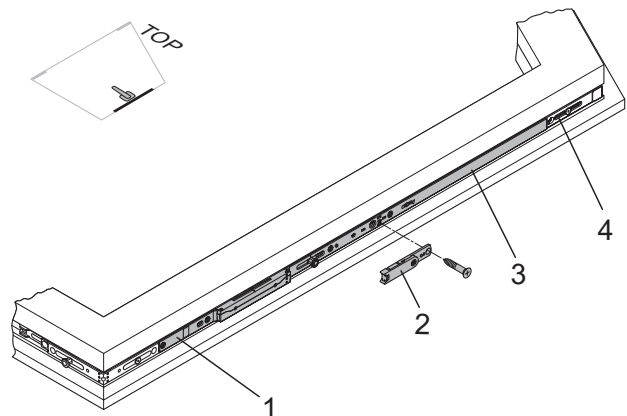

Drive rod GAM/GAK

way.

- Screw the drive rod from the bottom up.
- Insert the optional dual function element (2) and screw into place.

See figure: Top rod OS..., shear S...-A

- Connect shear and top rod:
 - Swivel out the hold-up shore (2) (see arrow).
 - Clip shear into the top rod (3) using mushroom bolt (4).
 - Press the shear bolt (5) into the spring on the hold-up shore.
 - Swivel the hold-up shore and shear to home position.

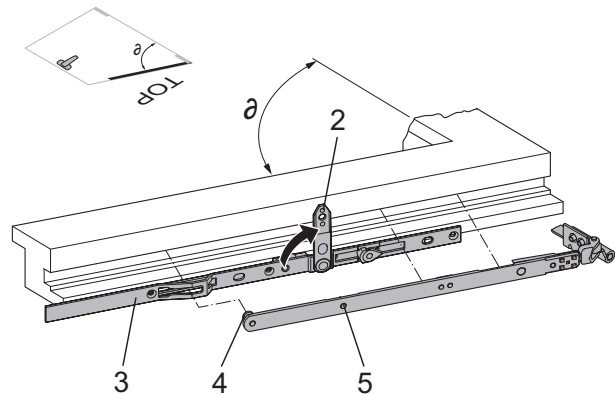

Top rod OS..., shear S...-A

See figure: Top rod OS..., shear S...-A

- Insert top rod OS... (1) and shear S...A into the eurogroove:
 - Insert a glazing block (d = 3 mm) between the shear hinge and sash to position the top rod.
 - Mark the length of the connecting rod at the joint edge of the corner drive.
 - Remove the top rod from the eurogroove.
 - Mark and trim the top rod using a punching press.



Note: The mark "X" determines the position of the connecting rail ASS AR7/OR-A (for top rod OS.2).

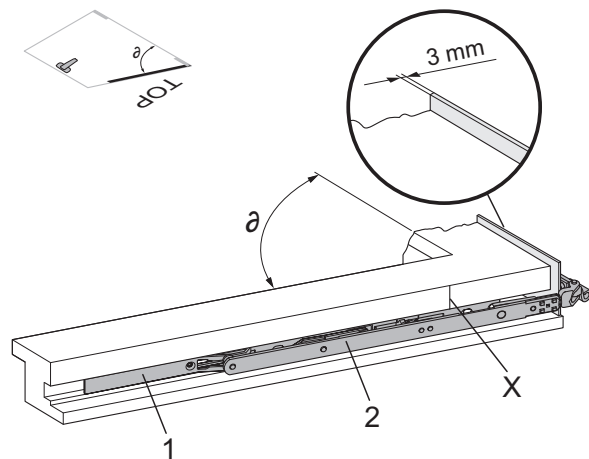

Top rod OS..., shear S...-A

See figure: Connecting rail ASS AR7/OR-A

- Mounting of the connecting rail:
 - Fit the connecting rail (1) into the fitting groove at the joint edge (X).
 - Screw-tight the corner drive at the top side.
 - Bend over the metal lug (2) and screw on.



Attention! Damage to sash frame. If you set the outer screw at too sharp an angle "alpha", there is a danger of the screw protruding hinge side and damaging the profile. You may need to fix the connecting rod at the top with just one screw.

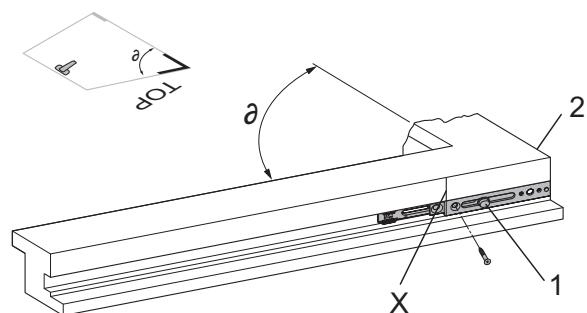

Connecting rail ASS AR7/OR-A

See figure: Top rod OS..., shear S...-A

- Screw on the top rod OS:
- Swivel out the shear (3).
- Fit the top rod (2) into the eurogroove and press flush against the connecting rail (4).
- Click the top rod gears into the teeth in the connecting rail.
- Clip the top rod (2) into the corner drive (1) in the same way.
- Screw the top rod towards the drive side.
- Swivel the shear (3) back into home position.

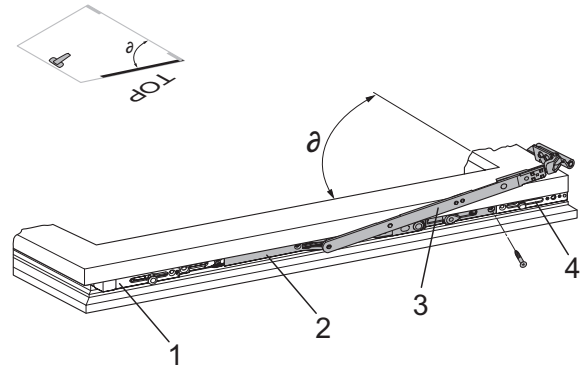

Top rod OS..., shear S...-A



Please note: When using the top rod OS1.600 please also insert an OS.A screw clip.

See figure: Sash hinge FL... / Mounting jig LE.B.FL...

- Fitting the sash hinge:
- Position the mounting jig (1), clamp into the fitting groove and drill \varnothing 6 mm holes for the hinge plugs.
- Pre-drill the screw holes through the first wall.
- Insert the sash hinge (2) and fix it in place.
- Make sure the sash hinge is fitted correctly into position.

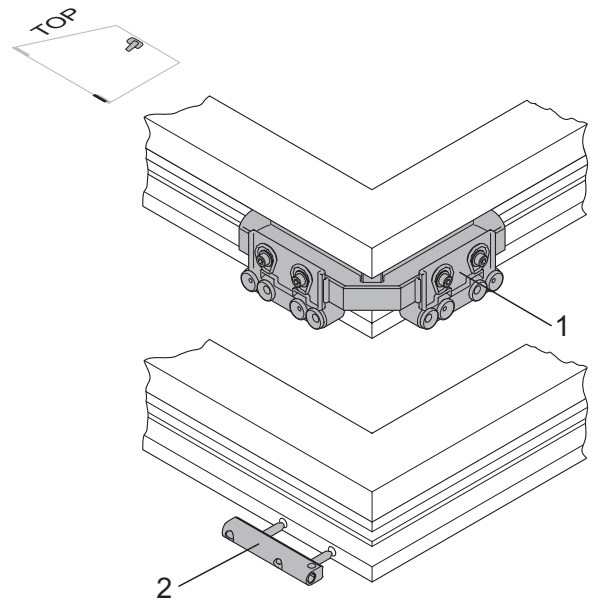

Sash hinge FL... / Mounting jig LE.B.FL...

See figure: Corner drive E1

- Fix the corner drive into place on the bottom side.
- Fit the corner drive (1) into the fitting groove at the bottom of the sash so that the octagonal bolt is on the underside.
- Fasten the corner drive into place with a screw.
- Measure the sash rebate width (FFB).

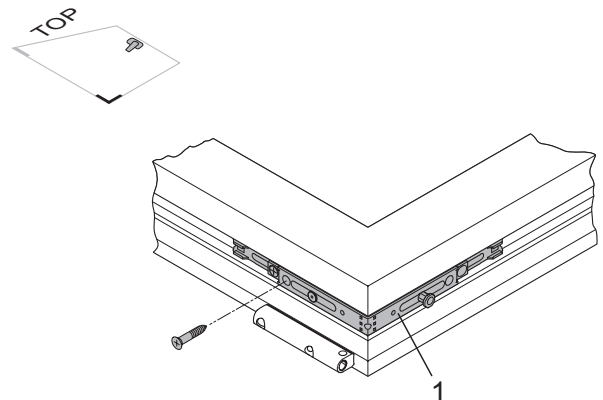

Corner drive E1

See figure: Interlocking rod MK (horizontal)

- Fit the interlocking rod at the bottom:
- Abut the interlocking rod (2) flush against the corner drive (1).
- Click the interlocking rod gears into the teeth of the corner drive.
- Press the interlocking rod into the fitting groove.
- Screw the interlocking rod in place.
- Tighten the screw (3) fully to release the central fastening.

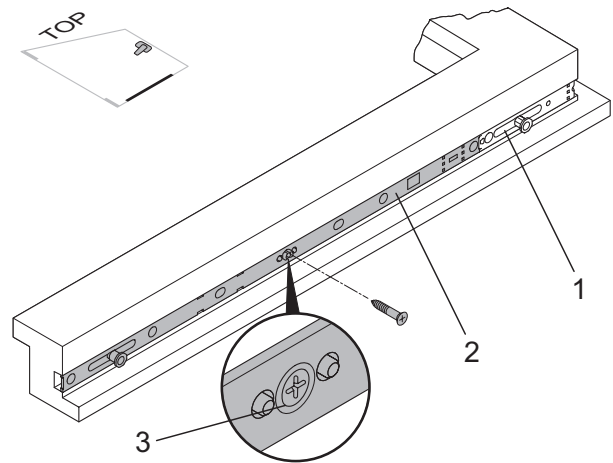

Interlocking rod MK (horizontal)

See figure: Coupling element KE (horizontal)

- Mount coupling element on the underside:
- Abut the coupling element (2) flush against the corner drive (1) and slot into eurogroove.
- Mark the length of the coupling element at the joint edge of the interlocking rod (3).
- Remove the coupling element from the eurogroove.
- Mark and trim the coupling element using a punching press.
- Abut the coupling element (2) flush against the corner drive (1).
- Click the coupling element into the teeth in the corner drive.
- Slot the coupling element into the gearing of the interlocking rod (3) in the same way.
- Press the coupling element into the eurogroove.
- Screw the coupling element in place.

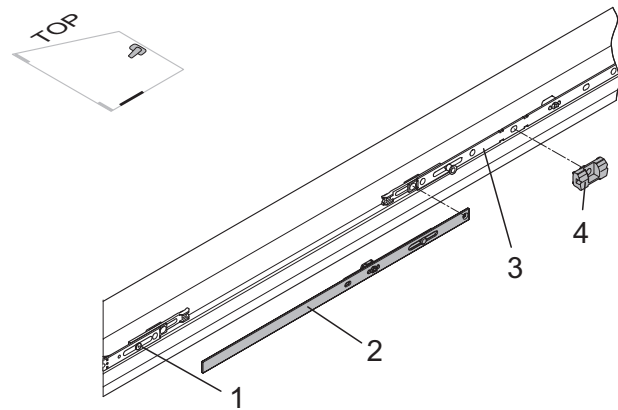

Coupling element KE (horizontal)

See figure: Interlocking rod M/MK (hinge side)

- Install Interlocking Rod on the hinge side.
- Fit the interlocking rod (1) flush against the corner drive (2).
- Click the interlocking rod gears into the teeth of the corner drive.
- Press the interlocking rod into the fitting groove.
- Screw the interlocking rod from the bottom up.
- Tighten the screw (3) fully to release the central fastening.



Attention! Damage to fittings. If the central fastening is not released, the gearing cannot be actuated. Use of force will lead to torsion of the fittings. Always insert the screw fully up to the stop.



Please note: The last locking point should be as close to the top as possible. You may need to fit multiple interlocking rods on hinge side for this reason.

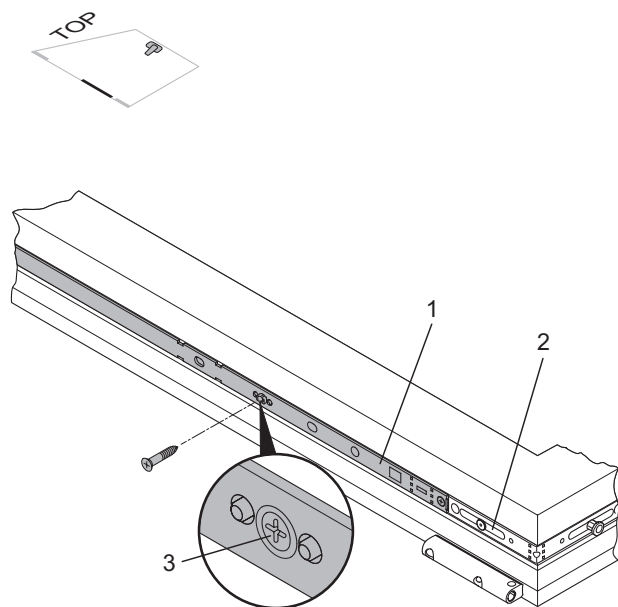

Interlocking rod M/MK (hinge side)

Mounting of fittings on the window frame

Turn-tilt type – studio window

See figure: Holes for corner and shear hinges

- Pre-drill the holes for the corner hinge as well as the pin positions (\varnothing 6 mm).
- Drill holes for the corner hinge (4) using the mounting jig LE.B.EL-SL.K (1) and for the shear hinge (3) using mounting jig SW-A (2). Distance between drill holes for shear and corner hinges is the same.



Please note: Do not fit shear hinges and corner hinges until after milling off the frame rebate edge and fitting the keeps.

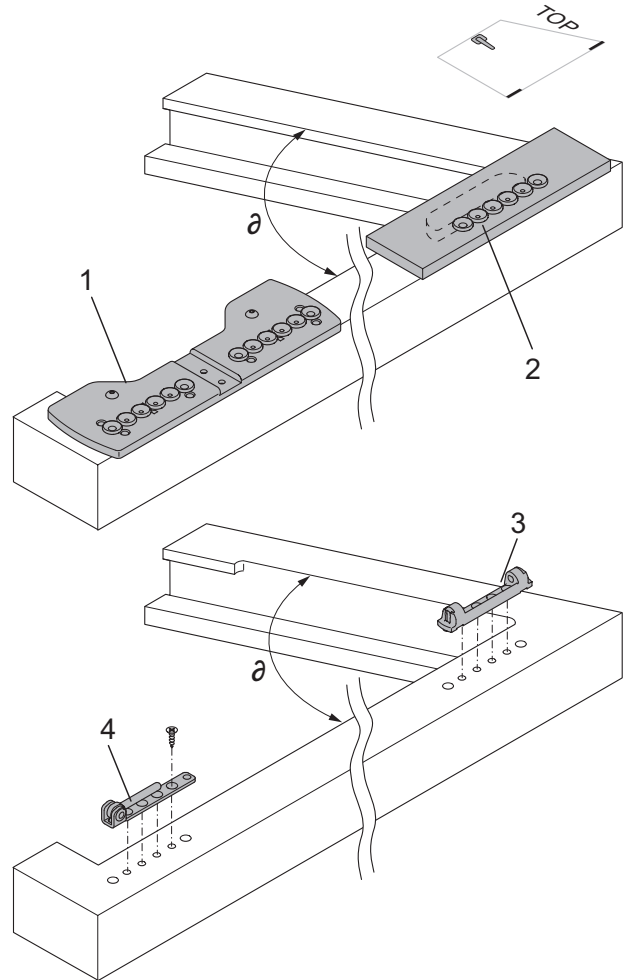

Holes for corner and shear hinges

See figure: Cut-out for shear arm

- Mill off the frame rebate edge to a length of approx. 250 mm using a router.



Attention! Damage to frame. To avoid the shear arm touching the frame when opening / closing the window, the frame rebate edge in the upper acute-angled area (1) of the profile must be bevelled or milled down. The length and slope of the routing depend on the angle of the upper corner.

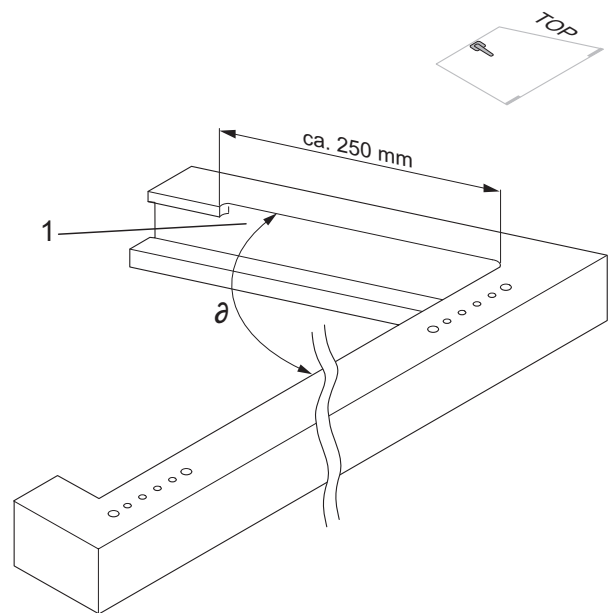

Cut-out for shear arm

Keep positions

The figures show the keep position options. The number of keeps depends on the size of the window.



Please note: The dimensions in the figures are from frame rebate edge to keep profile edge! Due to the top part of the frame not being right-angled for studio windows, it is impossible to use a mounting template to fit the keeps. This is why you need to mark the keep positions manually on the frame.

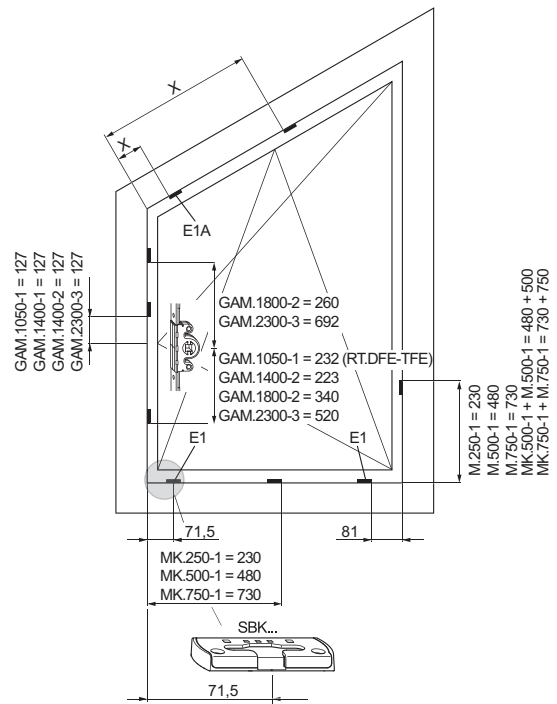

Keep positions "central handle position"
X = Dimension in elevation

See figure: Keep positions "constant handle position"

- Keep position X on slopes:
 - Mount the sash.
 - The handle is in horizontal position; the window is unlocked so that the mushroom heads are in a central position.
 - Abut the sash so that you can mark the outer edge of the mushroom bolt on the frame.
 - Position the keep:
 - The gap between the outer edge of the mushroom bolt and the profile edge of the keep is 3 to 4 mm.

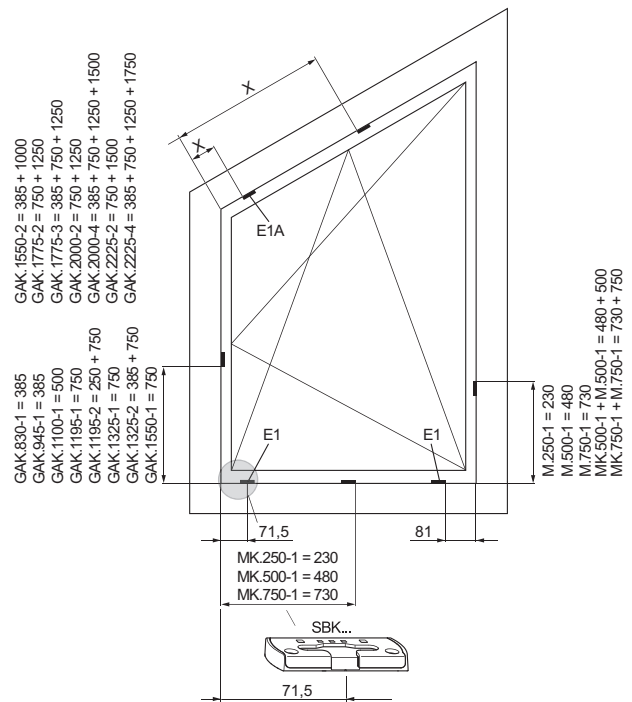

Keep positions "constant handle position"
X = Dimension in elevation



Please note: When marking, note the run-in sides of the keeps.

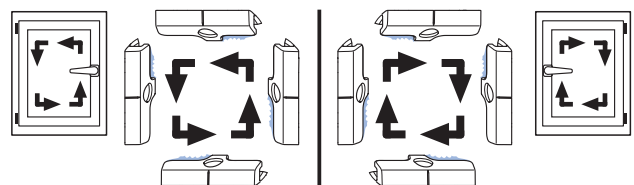

Run-in sides

Mounting of fittings on sash

Turn-tilt type – Round-arch window

Prepare the window for fitting. Then proceed as follows:



Please note: The following figures refer to a window for right-hand use. When fitting a window for left-hand use, the figures will be mirror-inverted.

The following also applies:

- When viewing the window from the inside, the symbol is depicted as a full line.
- When viewing the window from the outside, the symbol is depicted as a dotted line.

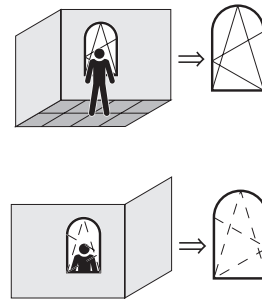

Determine the handle height:

Handle height for drive rod GAM

See figure: Sash rebate height FFH-R with central handle position GM

If you use a GAM drive rod (central handle position), dimension GM is half the sash rebate height FFH-R.

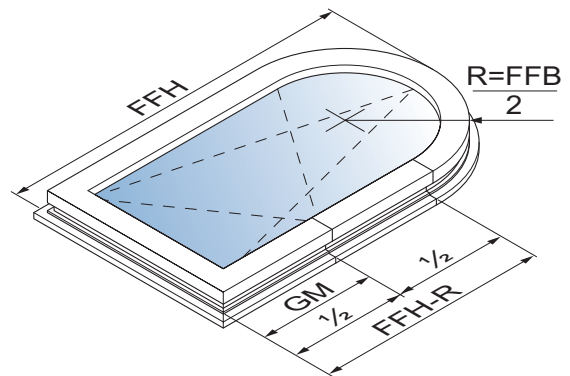

Sash rebate height FFH-R with central handle position GM

Handle height for drive rod GAK

See figure: Sash rebate height FFH-R with constant handle height GK

If you use a GAK drive rod ... (constant handle position), dimension GK changes to reflect the sash rebate height FFH-R. The exact dimensions are specified in the following table.

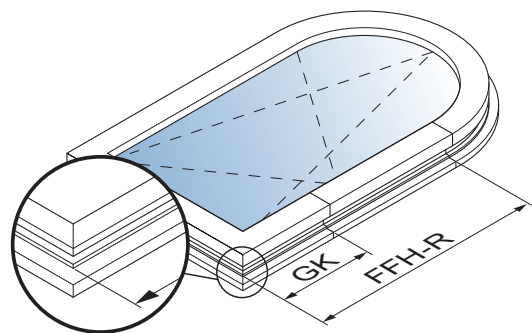

Sash rebate height FFH-R with constant handle height GK

See figure: Synoptical table sash rebate height (FFH-R) / handle position

The table on the right gives a survey on the handle height (GK) of GAK with regard to the sash rebate height (FFH).

FFH	
230 – 324	GK = 114 *
325 – 420	GK = 114 *
421 – 460	GK = 210
461 – 700	GK = 210
701 – 850	GK = 260
851 – 1100	GK = 375
1101 – 1325	GK = 550
1326 – 1525	GK = 550
1526 – 1775	GK = 550
1776 – 2000	GK = 1050
2001 – 2225	GK = 1050

Synoptical table sash rebate height (FFH-R) / handle position
* Requires the use of E3 corner drive

See figure: Scale drawing "Gear lock"

- Drill holes for gear case (ø 12 mm) as per scale drawing.
- Mill the gear housing from the rebate side.

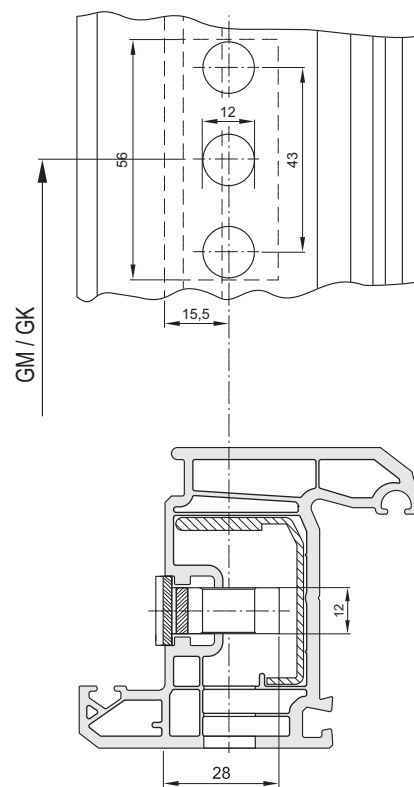

Scale drawing "Gear lock"

See figure: Corner drive E1

- Fix the bottom corner drive into place.
- Fit the corner drive (1) into the fitting groove at the bottom of the sash so that the octagonal bolt is on the underside.
- Attach the corner drive (1) hinge side with a single screw.

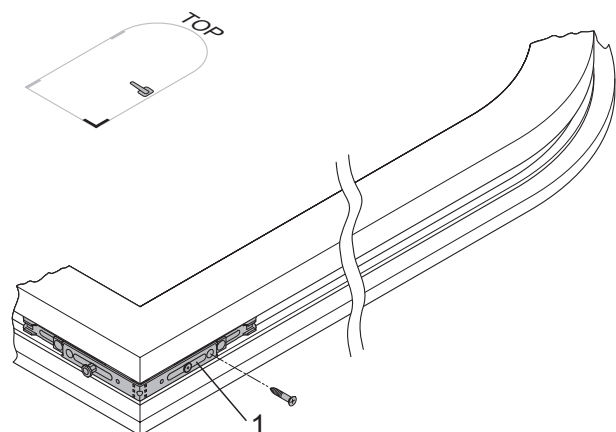

Corner drive E1



Please note: If sash rebate width $FFB < 750$ mm, the connecting rail AARB (1) must be shortened behind the drill hole for the second locking bolt.

Only for sash rebate width $FFB < 750$ mm:

See figure: Connecting rail AARB for $FFB < 750$ mm

- Before shortening, push the locking bolt (4) into locking position (see arrow) to make sure the spring (2) is cut at the right position.
- Saw through the connecting rail (3) at the notch (1).

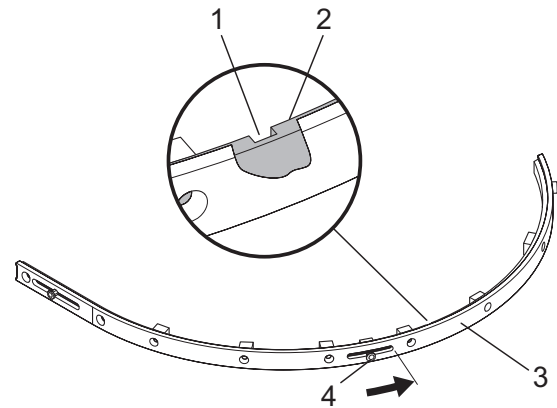

Connecting rail AARB for $FFB < 750$ mm

See figure: Connecting rail AARB

- Mounting of the connecting rail:
 - Make mark "FFH-R" on the sash.
 - Place the connecting rail (1) into the eurogroove, aligning the notch mark with the "FFH-R" mark.
 - Screw the connecting rail from the "FFH-R" mark in the direction of the bend.



Attention! Damage to connecting rail. You must not bend out the connecting rail (1) as it may otherwise buckle at drill hole positions. The connecting rail would not perfectly match the contour of the arch when screwed into place.

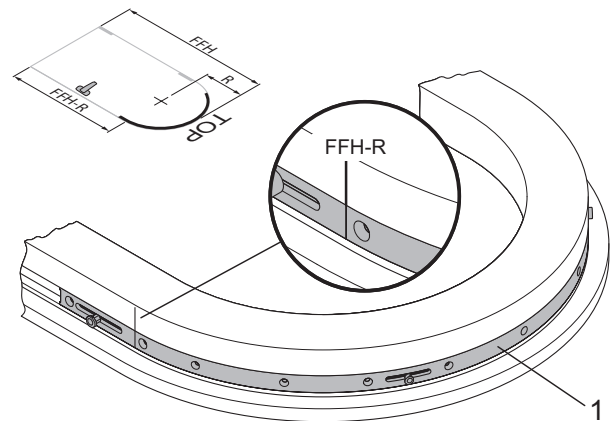

Connecting rail AARB

See figure: Drive rod GAM/GAK

- Mount the drive rod:
 - Press the drive rod into the eurogroove.
 - Fit the handle to position the drive rod.
 - Mark the length of the drive rod on the butt joint with the corner drive (1) and on the butt joint with the connecting rail (4).
 - Remove the handle and take the drive rod out of the fitting groove.
 - Mark and trim the drive rod using a punching press.
 - Mount the drive rod:
 - Abut the drive rod (2) flush against the corner drive (1).
 - Allow the teeth on the drive rod to click into position on the gear rack on the corner drive.
 - Clip the drive rod into the connecting rail (4) in the same way.
 - Screw the drive rod from the bottom up.
 - Insert the optional dual function element (3) and screw into place.

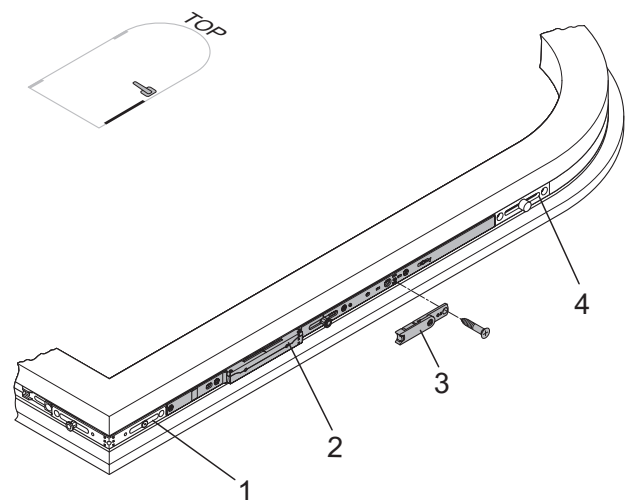

Drive rod GAM/GAK

See figure: Sash hinge FL... / Mounting jig LE.B.FL...

- Fitting the sash hinge:
 - Position the mounting jig LE.B.FL (1) and drill \varnothing 6 mm holes hinge side for the hinge plugs. Drilling depth min. 20 mm.
 - Pre-drill the screw holes through the first wall.
 - Insert the sash hinge (2) and fix it in place.
 - Make sure the sash hinge is fitted correctly into position.

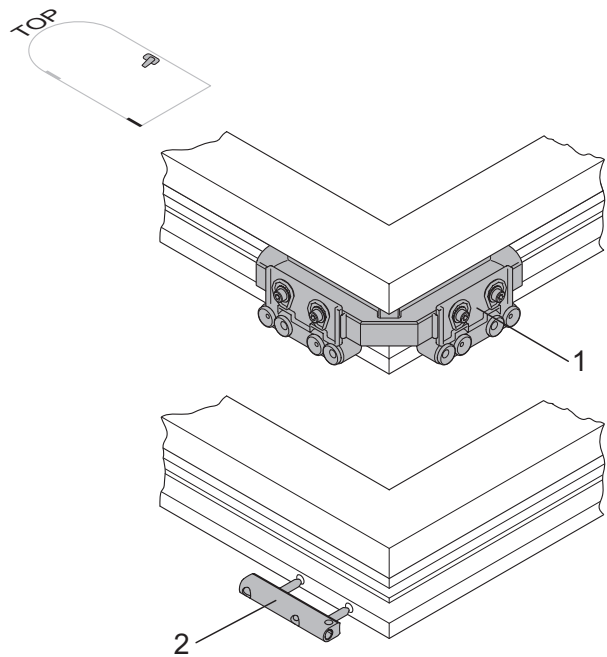

Sash hinge FL... / Mounting jig LE.B.FL...

See figure: Corner drive E1

- Fix the bottom corner drive into place.
 - Fit the corner drive (1) into the fitting groove at the bottom of the sash so that the octagonal bolt is on the underside.
 - Fix the corner drive in place with a single screw hinge side.
 - Measure the sash rebate width (FFB).

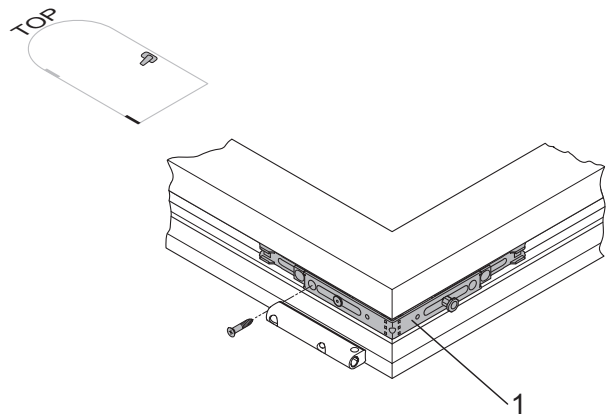

Corner drive E1

See figure: Interlocking rod MK (horizontal)

- Mount interlocking rod on the underside:
 - Abut the interlocking rod (2) flush against the corner drive (1).
 - Click the interlocking rod gears into the teeth of the corner drive.
 - Press the interlocking rod into the fitting groove.
 - Screw the interlocking rod in place.
 - Tighten the screw (3) fully to release the central fastening.



Attention! Damage to fittings. If the central fastening is not released, the gearing cannot be actuated. Use of force will lead to torsion of the fittings. Always insert the screw fully up to the stop.

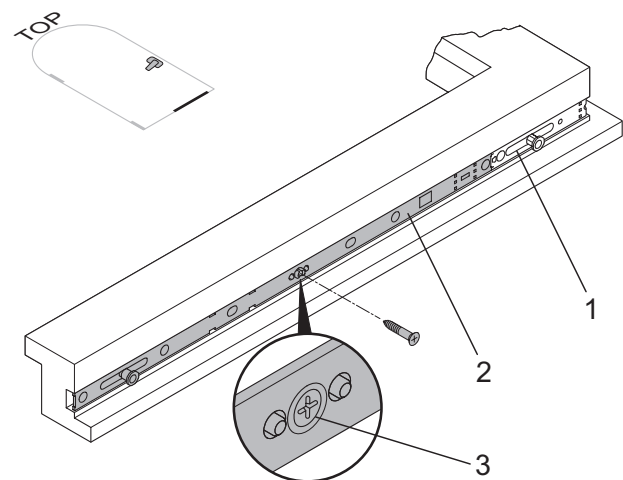

Interlocking rod MK (horizontal)

See figure: Coupling element KE (horizontal)

- Mount coupling element on the underside:
 - Abut the coupling element (2) flush against the corner drive (1) and slot into eurogroove.
 - Mark the length of the coupling element at the joint edge of the interlocking rod (3).
 - Remove the coupling element from the eurogroove.
 - Mark and trim the coupling element using a punching press.
 - Abut the coupling element (2) flush against the corner drive (1).
 - Click the coupling element into the teeth in the corner drive.
 - Slot the coupling element into the gearing of the interlocking rod (3) in the same way.
 - Press the coupling element into the eurogroove.
 - Screw the coupling element in place.

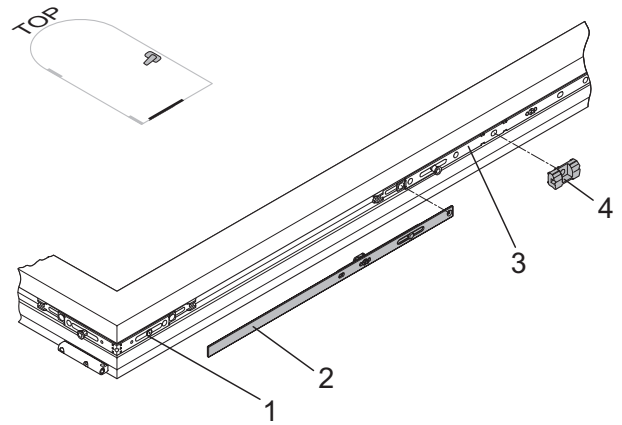

Coupling element KE (horizontal)



Attention! Check if all screws are fixed into place on the fitting parts.

- Clip the run-up block (4) into the interlocking rod (3) and screw into place.

See figure: Shear GRT.SWR

- Mounting the shear:
 - Make mark "FFH-R" on the sash.
 - Place the shear (2) into the fitting groove, aligning the notch mark with the "FFH-R" mark.
 - Fix the shear (2) in place with a single screw.

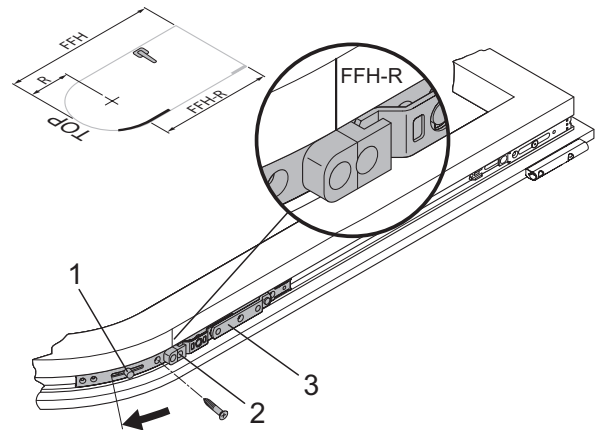

Shear GRT.SWR

See figure: Shears

- Screw the shear into position.
 - To swivel out the shear arm (2), push the locking bolt (1) to tilt position (see arrow).
 - Swivel out the shear arm (2).
 - Screw the shear into position.

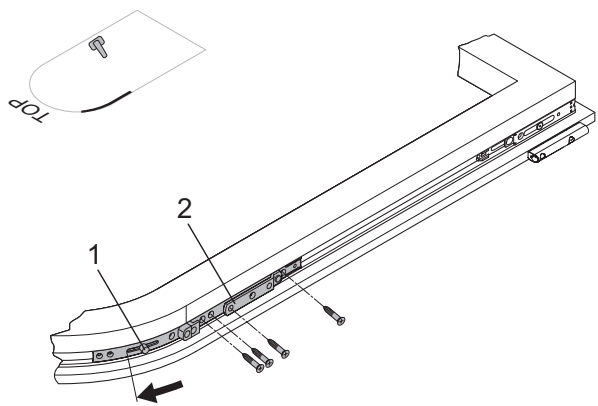

Shears

13.5

See figure: Shear hinge

- Insert the shear hinge (3) into the shear arm (4):
- The shear hinge must point towards the sash overlap.
- After mounting the shear hinge, turn the hammerhead (1) through 90° using a T20 (Torx) tool.
- Swivel the shear arm (4) back in.
- Push the locking bolt (2) back to the centre position (see arrow) to allow a correct combination of the shear with the connecting rod RB.

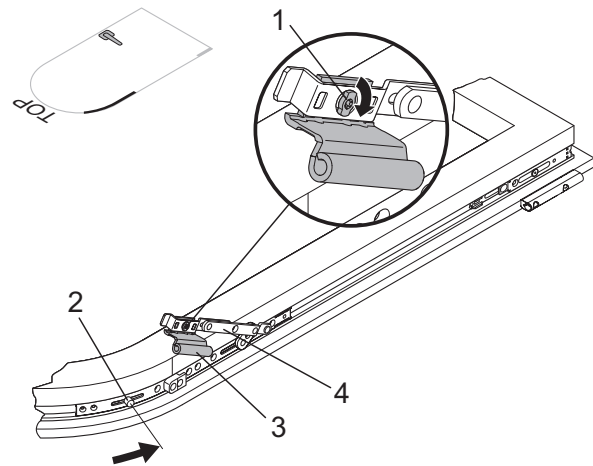

Shear hinge

See figure: Interlocking rod MK

- Mount the interlocking rod MK hinge side depending on the height of FFH-R:
- Select an interlocking rod to match the sash rebate height FFH-R and the length of connecting rod RB.
- Fit the interlocking rod (1) flush against the corner drive (3).
- Click the interlocking rod gears into the teeth of the corner drive.
- Press the interlocking rod into the fitting groove.
- Screw the interlocking rod from the bottom up.
- Tighten the screw (2) fully to release the central fastening.

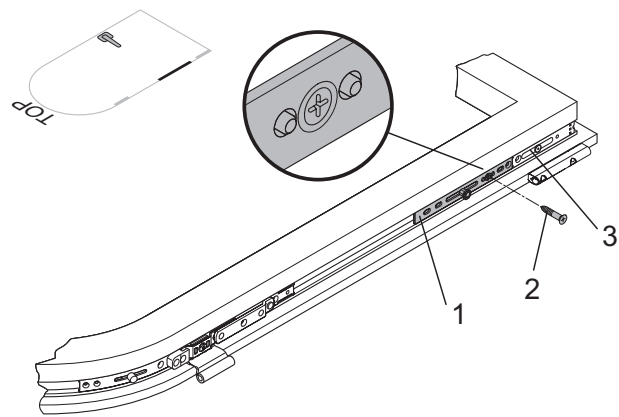

Interlocking rod MK



Attention! Damage to fittings. If the central fastening is not released, the gearing cannot be actuated. Use of force will lead to torsion of the fittings. Always insert the screw fully up to the stop.

See figure: Connecting rod RB / RB-K

- Abut the connecting rod (2) with the shear (1) and slot into the eurogroove.
- Mark the length of the connecting rod at the joint edge of the interlocking rod (3).
- Remove the connecting rod from the eurogroove.
- Mark and trim the connection rod using a punching press.
- Abut the connecting rod (2) flush against the shear (1).
- Click the connecting rod gears into the teeth of the shear.
- Slot the connecting rod into the gearing of the interlocking rod (3) in the same way.
- Press connection rod into the fitting groove.
- Screw the connection rod into position.

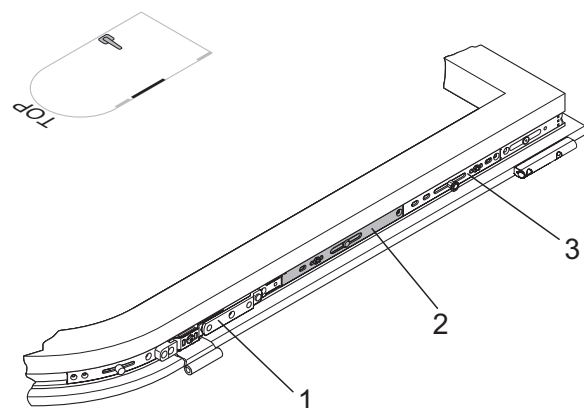

Connecting rod RB / RB-K



Attention! Check if all screws are fixed into place on the fitting parts.

See figure: Connecting plate

- Place the connecting plate (2) in the shear (1) and connecting rod (3) notch and screw tight.

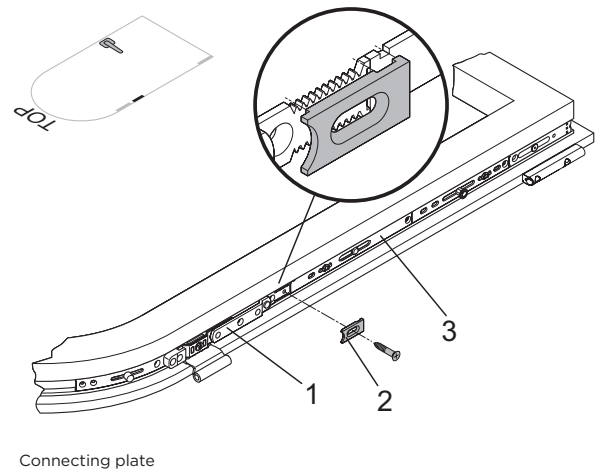

Connecting plate

Mounting of fittings on the window frame

Turn-tilt type – Round-arch window

See figure: Corner hinge EL.../ drilling jig LE.B.EL...

- Mounting the corner hinge.
- Pre-drill the holes for the corner hinge as well as the pin positions (\varnothing 6 mm).
- Drill holes for corner hinge (2) in line with mounting jig (1).
- Fit the corner hinge (2) and use screws to fasten in place in line with product instructions.

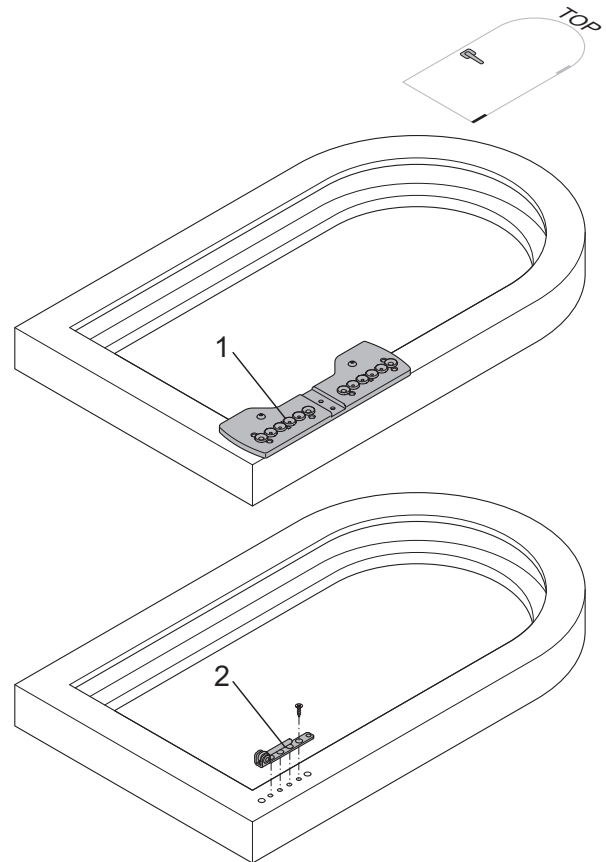

Corner hinge / drilling jig

See figure: Shear hinge SWR ... for round arch

- Mount the shear hinge.
- Mount the shear hinge (3) on the shear band (2) using the pin (4).
- Mount the sash.
- Place the sash on the corner hinge (5).
- Place the sash on the frame.
- Press the sash and shear hinge as far out as possible (see arrow) against the frame edge.
- Pre-drill the screw positions (4x) through the shear hinge holes (1).
- Screw the shear hinge into place (screws in line with details in Product Liability Information).

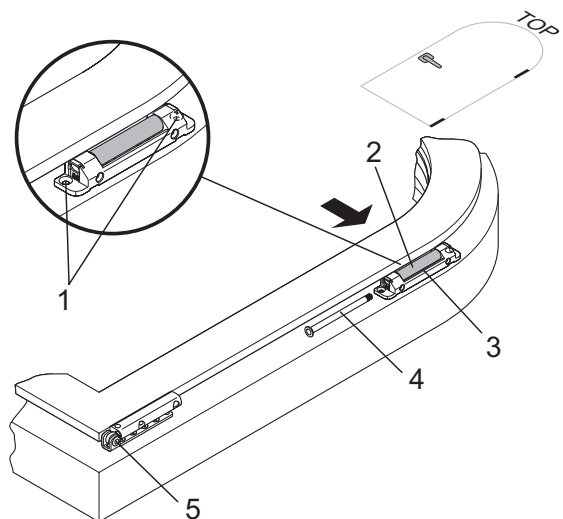

Shear hinge SWR ... for round arch

Keep positions

The figures show the keep position options. The number of keeps depends on the size of the window.



Please note: The dimensions in the figures are for frame rebate edge to keep profile edge! Due to the top part of the frame not being right-angled in round-arch windows, it is impossible to use a mounting template to fit the keeps. This is why you need to mark the keep positions manually on the frame.

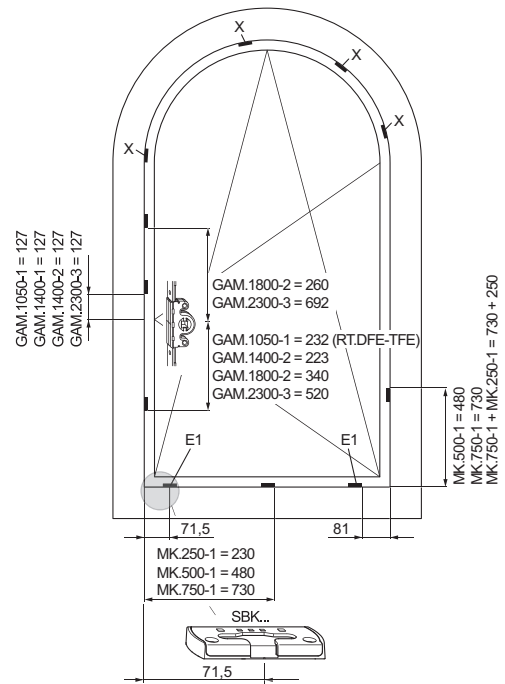

Keep positions "central handle position"
X = Dimension in elevation

- Keep position x on the round arch:

Initial situation:

- Mount the sash.
- The handle is in horizontal position; the window is unlocked so that the mushroom heads are in a central position.
- Abut the sash so that you can mark the outer edge of the mushroom bolt on the frame.
- The gap between the outer edge of the mushroom bolt and the profile edge of the keep is 3 to 4 mm.

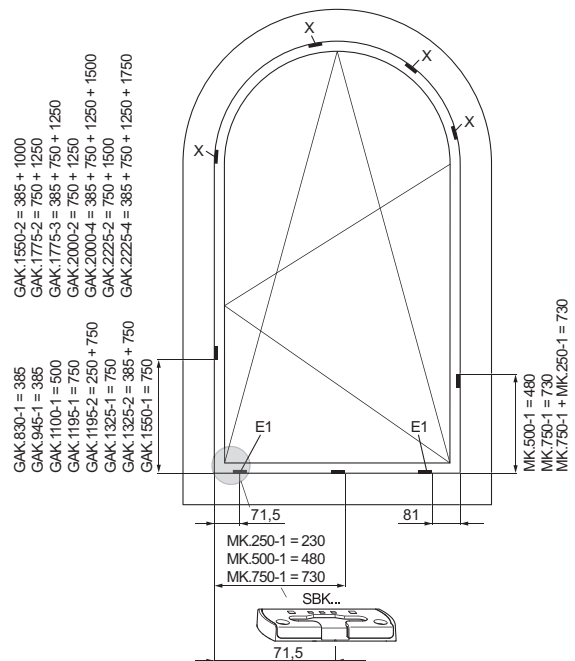

Keep position "constant handle position"
X = Dimension in elevation

Position the keep:

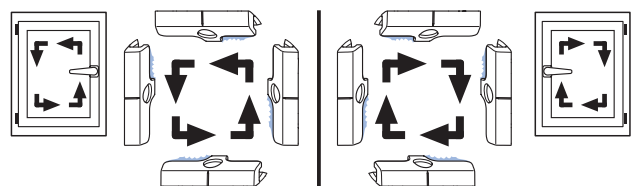

Run-in sides

Fitting the sash

See figure: Removing the retaining screw

- Remove the retaining screw (1) before mounting the sash.
- Set the shear arm (2) parallel to the shear casing.
- Mount the sash, move it into the sealing plane and secure in the shear hinge using the pin.

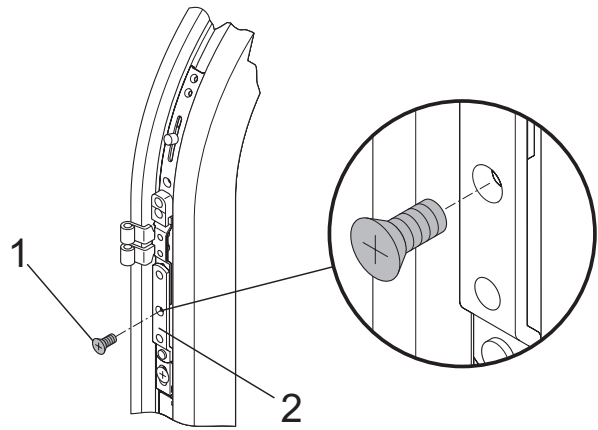

Removing the retaining screw

Security tilt keep SBK... and limiter K-SEF-1

See figure: Position of limiter K-SEF

For round-arch windows you need a security tilt keep SBK... and additionally a "Limiter K-SEF".

- Position the limiter (3) on the profile edge of the keep (1).
- Label the screw hole (2).
- Drill pilot holes into the tilt keep (1).
- Screw the shootbolt keep into the tilt keep.

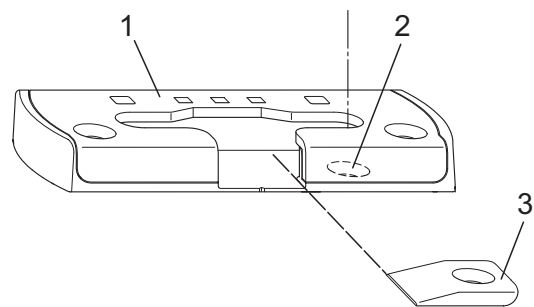

Position of limiter K-SEF

Function test / Operation

Turn-tilt type

See figure: Function test turn-tilt window

- Place the handle and operate once as follows to release the central fastening.
- Push the handle down (c). The window is closed.
- Move the handle to the central position (a). The window is unlocked; the sash can now be opened fully.
- Close sash. Push the handle up (b). The window is unlocked; the sash can now be tilted.



Please note: Initial actuation is not as easy as actuation in normal operations. A clicking noise will be heard during actuation. Keep the window closed during actuation.

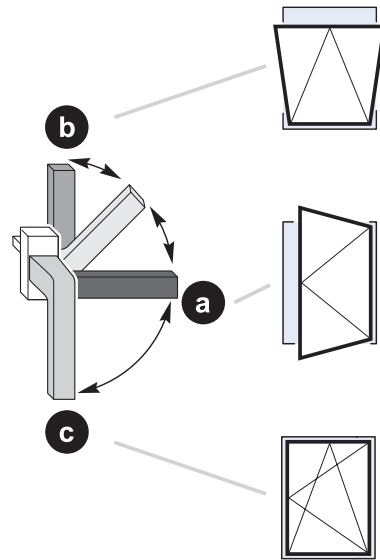

Function test turn-tilt window

Turn double sash type

See figure: Function test turn double sash window

- Actuate the handle as follows to release the central fastening.
- Press the unlocking button (1) and press the lever down to its limit position.
- The window is unlocked; the sash can now be opened fully.



Please note: When you lift the lever for the first time, the gearing is “unblocked” and coupling to the connected fittings is established. Thus, the initial actuation is not as smooth as in normal operations. A clicking noise will be heard during initial actuation. Keep the window closed during actuation.

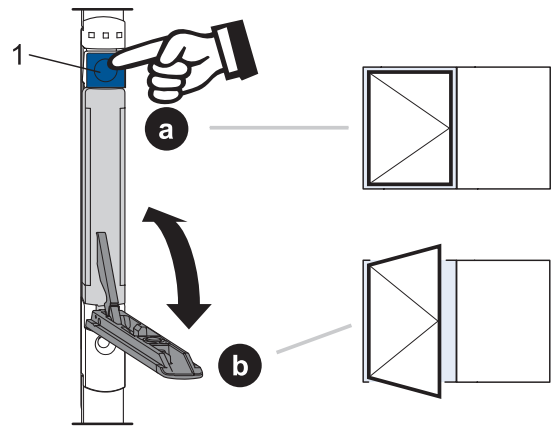

Function test turn double sash window

Notes on professional fitting and removing of sashes

For professional mounting and removal of the window sash please refer to our mounting advice. We recommend to place this mounting advice on the window sash.

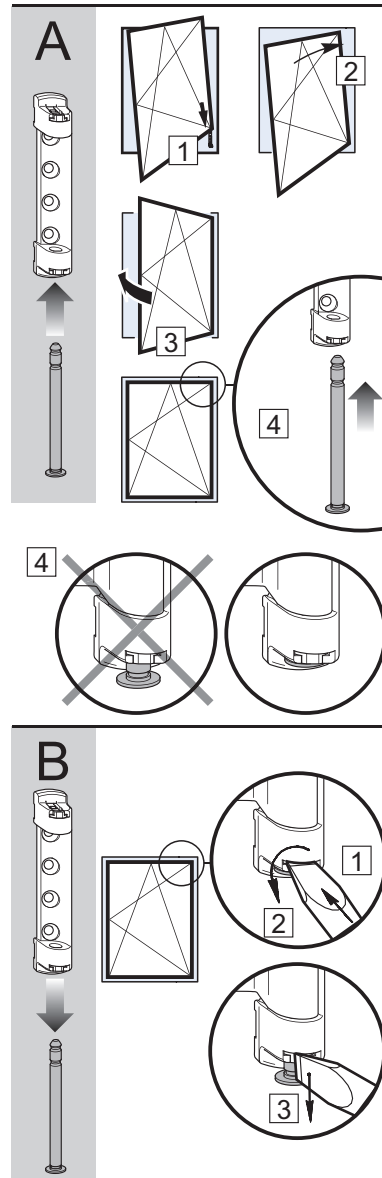
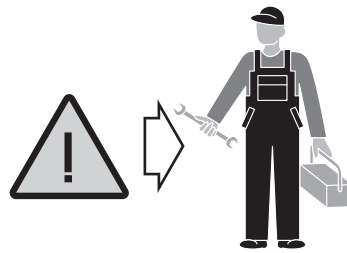

Mounting of accessories

Window Limiter FBP-11 SL

Window Limiter FBP-11-650 SL

Installation on the frame

The frame plate must be positioned according to the drawing and it must be screwed flush with the inner edge of the frame.

In case of profiled frames it is important to use spacers FT WSK ... for adaption.

Number of spacers FT WSK: 2 pcs per frame plate

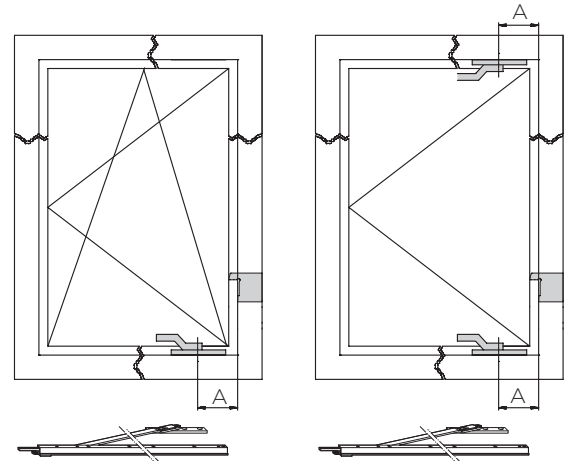

FBP-11 A = 113 mm
FBP-11-650 A = 50 mm

Assembly on the upper sash

Turn sash (D)

- Insert the window limiter into the eurogroove, then screw into place flush with the sash rebate edge on the hinge side.
- Handle position "open"
- When installing the window limiter "top" please make sure that the connection rod is compression mounted.
- Observe the marks on the control rail.
- Mark and trim the connection rod using a punching press.
- Screw the connection rod into position.

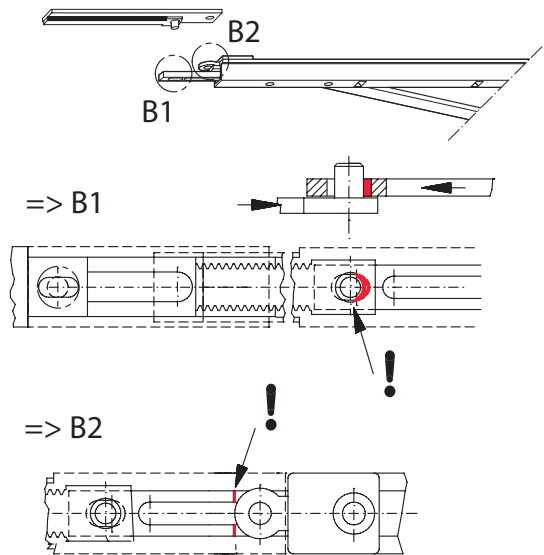

i Note: The braking force can be adjusted by inserting the connection rod gears into the tothing system in an offset manner.

Assembly on the bottom sash

Turn-tilt sash (DK)

- Insert the window limiter into the eurogroove, then screw into place flush with the sash rebate edge on the hinge side.
- Handle position "open"
- When mounting the window limiter "bottom" please make sure that the connection rod is installed "to tension".
- Observe the marks on the control rail.
- Mark and trim the connection rod using a punching press.
- Screw the connection rod into position.

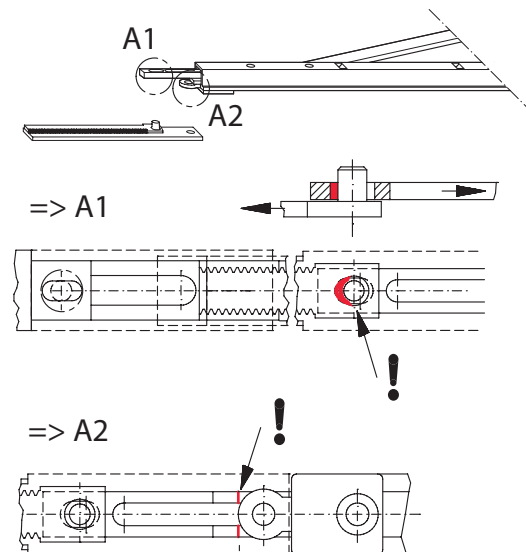

i Note: The braking force can be adjusted by inserting the connection rod gears into the tothing system in an offset manner.

Adjustment options

Corner hinge/sash hinge

Sash hinge height adjustment (± 3 mm) and corner hinge side adjustment (± 2 mm).

For sash hinge adjustment of the contact pressure between sash and frame (± 1.2 mm) using a 2.5 mm Allen key.

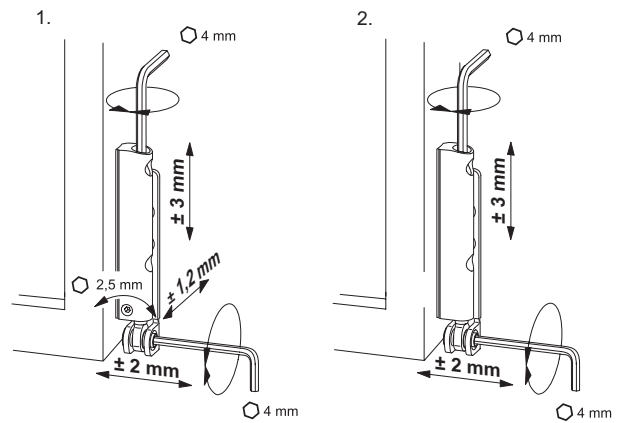

1. with contact pressure adjustment
2. without contact pressure adjustment

Octagonal bolt

Regulate the contact pressure between the sash and the frame (± 0.8 mm) by turning the octagonal bolt. The adjustment can be carried out by means of the Winkhaus adjustment key (V.ST.SCH.HV-11).

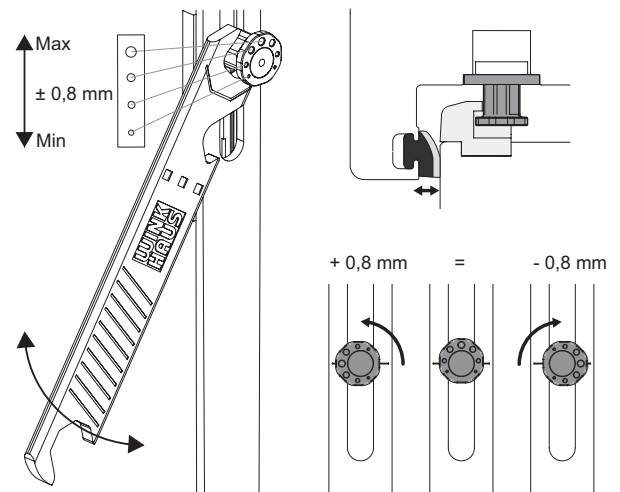

Octagonal bolt

Shear retraction

The progressive shear pull-in is adjustable from 18 to 28 mm. Release the catch by pulling up on the adjustment latch then pivot the adjustment latch away from the overlap. A variable tilt device, MSL.OS, can be used as an alternative to the progressive shear pull-in.

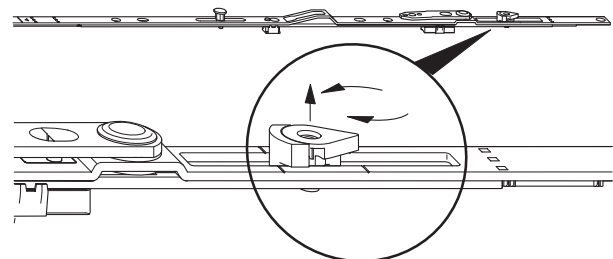

Shear retraction

Shear - rectangular window

Lifting and lowering the sash (from -2 to +3.5 mm) by means of a 4 mm Allen key.

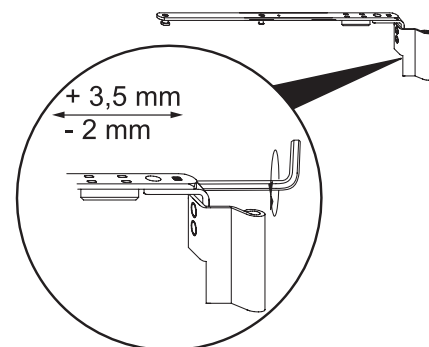

Shear - Rectangular window

Shear - studio window

Lifting and lowering the sash and adjustment of contact pressure by means of a 4 mm Allen key.

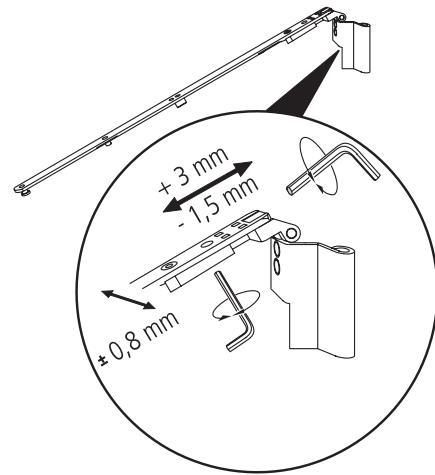

Shear - studio window

Shear - round-arch window

Lifting and lowering the sash and adjustment of contact pressure by means of a 4 mm Allen key.

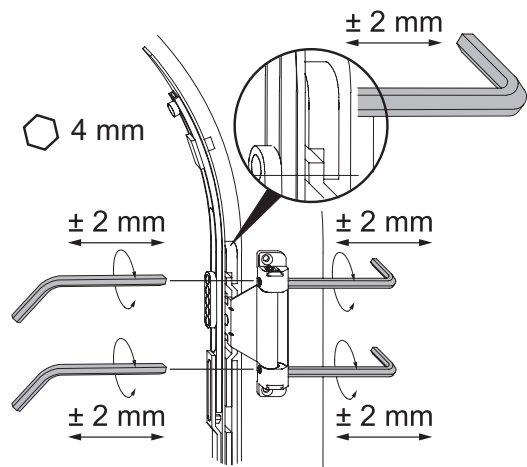

Shear - round-arch window

Fail safe device FSF

After installation the tip of the pressure piece must be directed towards the frame! For airgaps smaller or larger than 12 mm an adjustment is possible by turning the plastic part to the left or to the right!

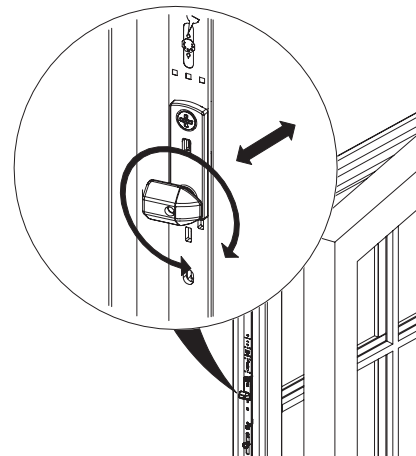

Fail safe device FSF

Adjustment and maintenance

Dual/triple function element

DFE/TFE activation

The DFE/TFE element is supplied in the neutral position. Please proceed as follows:
 Drive in the protruding pin to fix in place (1).
 Can be used left/right by swivelling out the lever once only.
 Dribble a few drops of oil (free of resin and acid) onto lubrication points.

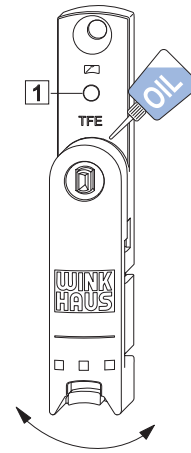

DFE/TFE activation

TFE – Retaining force of balcony door catch

Adjusting the holding force by re-setting the eccentric cam with a 4 mm Allen key. Dribble a few drops of oil (free of resin and acid) onto lubrication points.

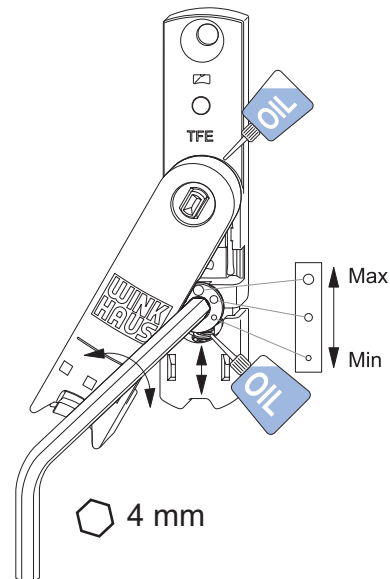

TFE – Retaining force of balcony door catch

Frame part DFE/TFE

Height adjustment (+/- 3 mm) for sash support plate. Each time fittings are adjusted, the DFE/TFE height setting should also be checked using a 2.5 mm Allen key.

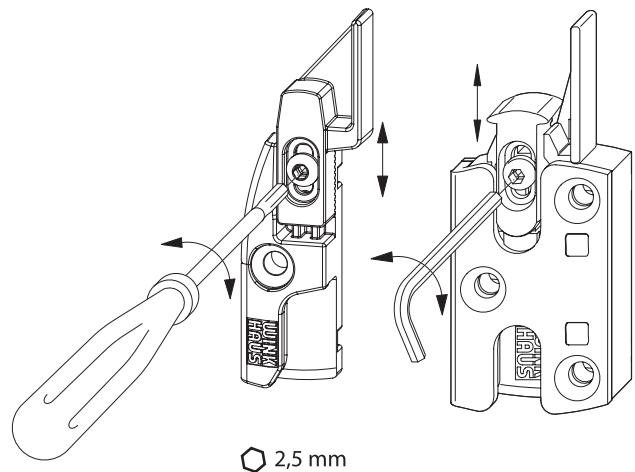

Frame part DFE/TFE

Maintenance

Lubrication points

See figure: Overview of lubrication points

The figure shows the location of possible lubrication points which should be lubricated at least once a year.

Positions A, C, D = lubrication points relevant to function.



Please note: The fitting schematic shown adjacent does not necessarily match the existing fitting. The number of locking positions will vary depending on size and type of the window sash.



Attention! Risk of injury. The window could fall on removal and thus injure persons. Do not remove the window for maintenance.

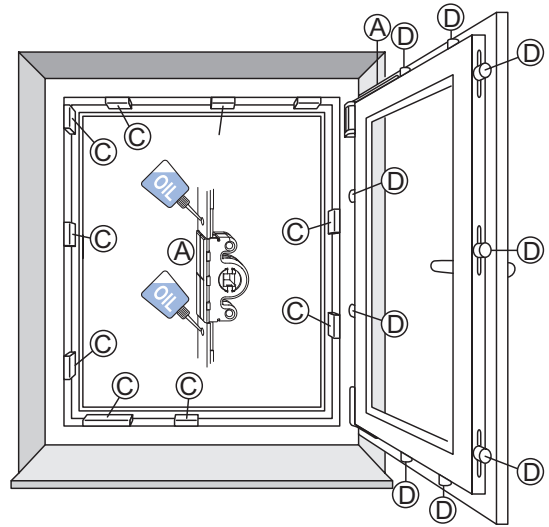

Overview of lubrication points

Keeps

See figure: Lubrication points

To keep fittings running smoothly, you must lubricate the keeps at least once a year.

- Lubricate the keeps (C) at the run-in side with technical Vaseline or any other suitable grease.
- Coat the running surfaces of the locking bolts (D) with an oil that is free of resins and acids.

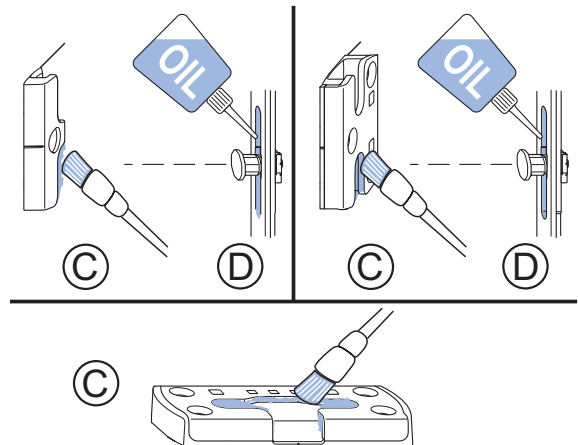

Lubrication points

Ascertaining the run-in sides

See figure: Run-in sides

- Left-handed window; handle right
- Right-handed window; handle left

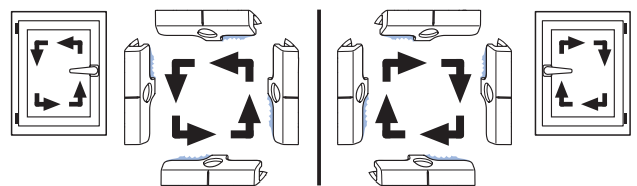

Run-in sides

Shears

See figure: Shears

All of the shear's contact points with the top rod should be oiled at least once annually.



Note: The shear hinge must not be oiled or greased.

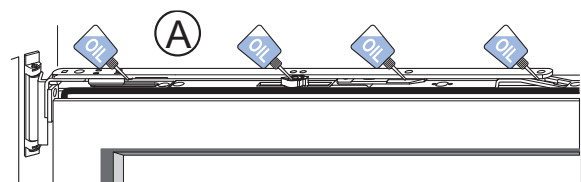

Shears

Installation drawings

Drive rods

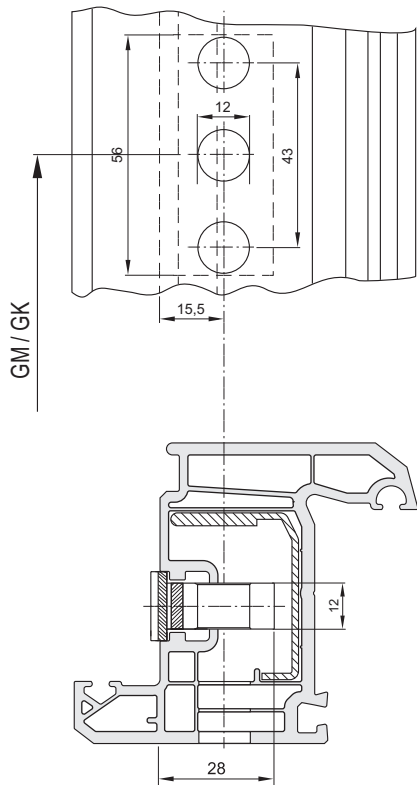

B-3-1: Drilling and milling instructions GAK/GAM ... D = 15.5 mm

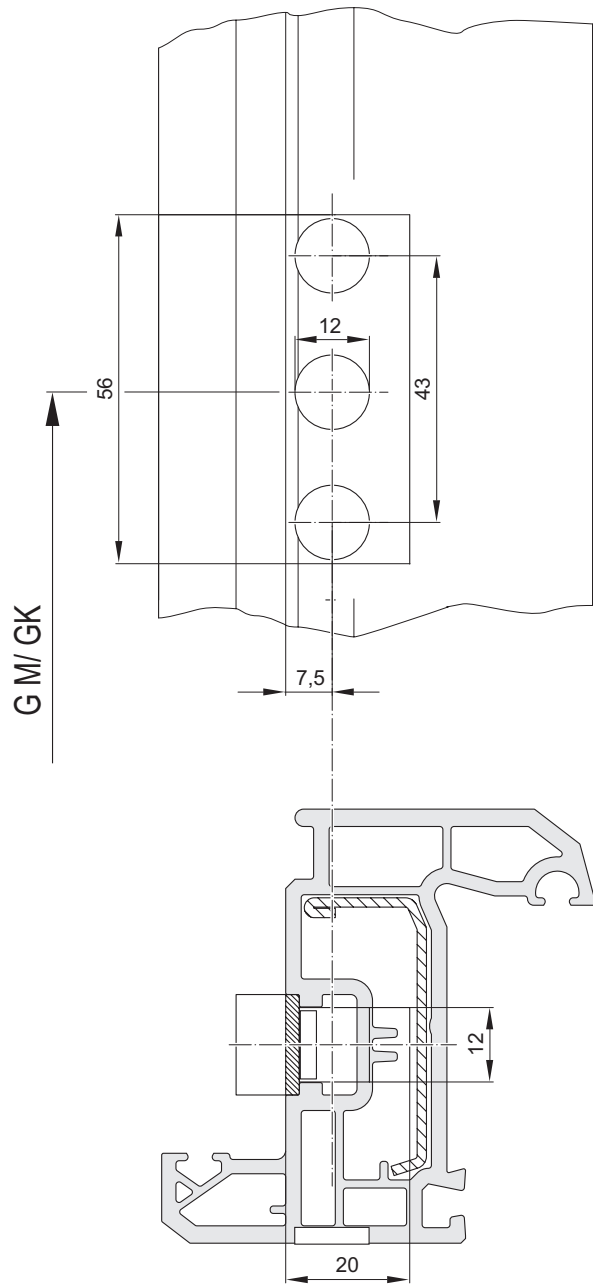

B-3-2: Drilling and milling instructions GAK/GAM ... D = 7.5 mm

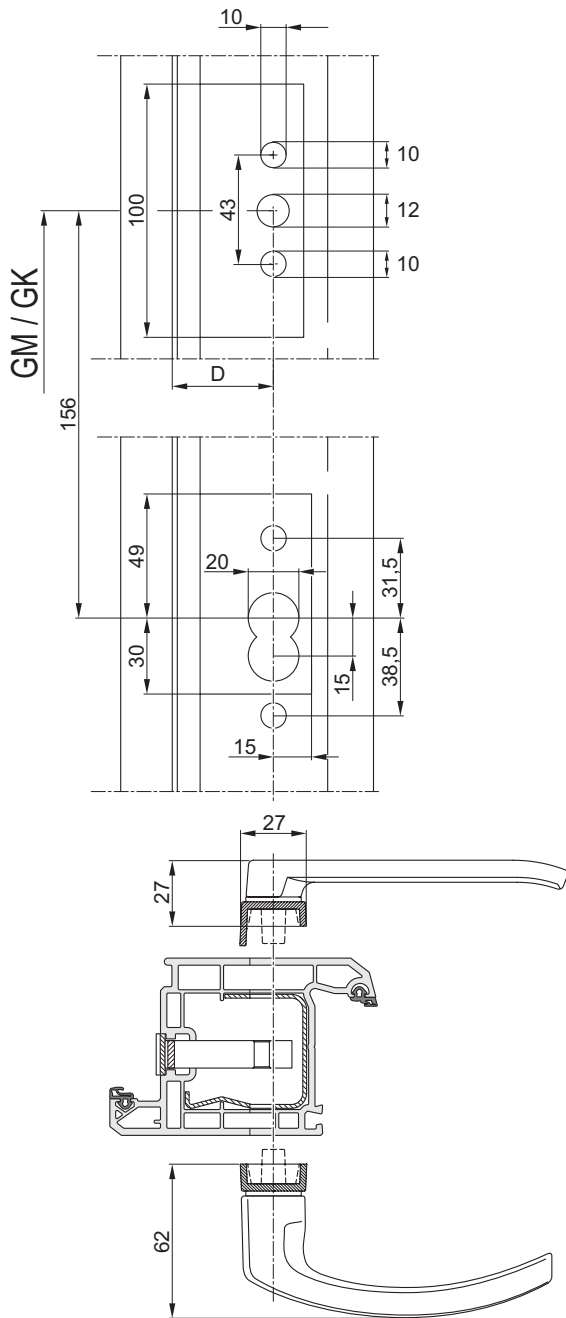

B-3-3: Drilling and milling instructions GAKA/GAMA D ...
D = Backset

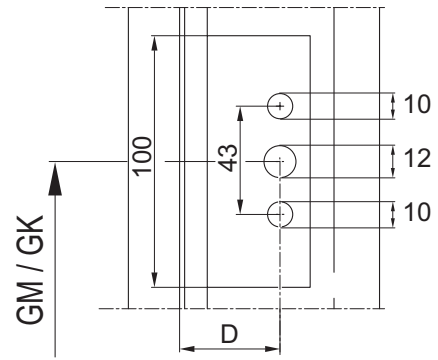

B-3-4: Drilling and milling instructions GAK/GAM ... D 25 ... 50
D = Backset

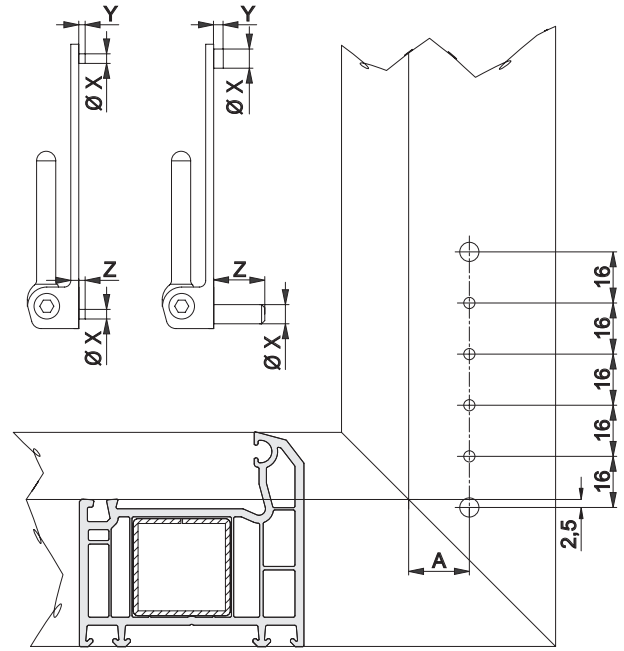
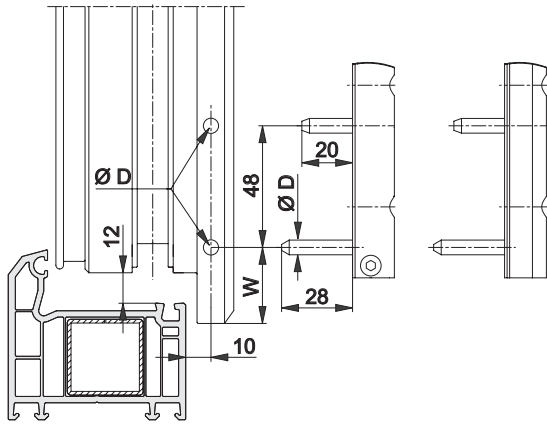

	UEB	SK...	Ø D	W
FL.K.20-6-20	20	...20-9	6	30
FL.KA.20-6-20				
FL.K.20-6-28				
FL.KA.20-6-28				
FL.K.20-6-20	20	...20-13	6	30
FL.KA.20-6-20				
FL.K.20-6-28				
FL.KA.20-6-28				
FL.K.20-6-20	21	...21-13	6	31
FL.KA.20-6-20				
FL.K.20-6-28				
FL.KA.20-6-28				
FL.K.20-6-28.130	20	...20-9	6	38
FL.K.20-6-28.130	20	...20-13	6	38
FL.K.20-6-28.130	21	...21-13	6	39
FK-F 20-6/20	20	...20-9	6	38
FK-F 20-6/20	20	...20-13	6	38
FK-F 20-6/20	21	...21-13	6	39
FK-F 20-6/28	20	...20-9	6	38
FK-F 20-6/28	20	...20-13	6	38
FK-F 20-6/28	21	...21-13	6	39

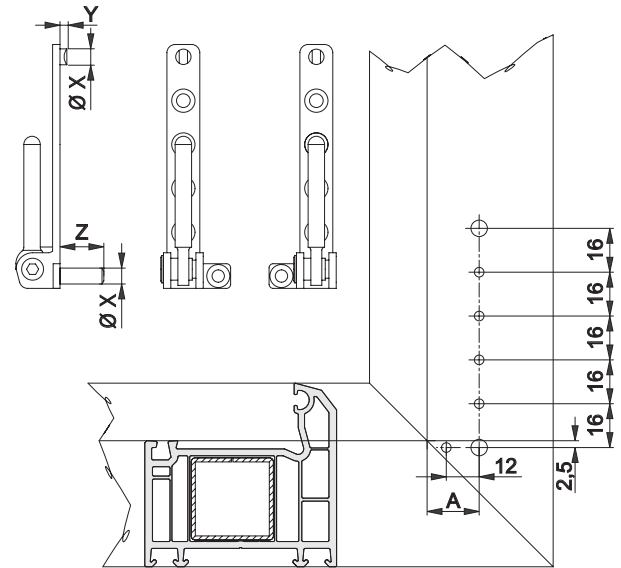

B-6-2: Drilling and milling instructions FL.K./FL.KA. ...
UEB = overlap

UEB	A
20	19
21	20

ELK. X - Y - Z
 EL.KB. X - Y - Z
 ESV X - Y - Z
 ESVW X - Y - Z

X=6
 Y=3
 Z=16
ELK6-3-16

B-6-3: Drilling template corner hinge EL.K./ESV... (top) / EL.KB.../ESVW... (bottom)
UEB = overlap

Shears / shear hinges

SL.KS... / SL.KS...130

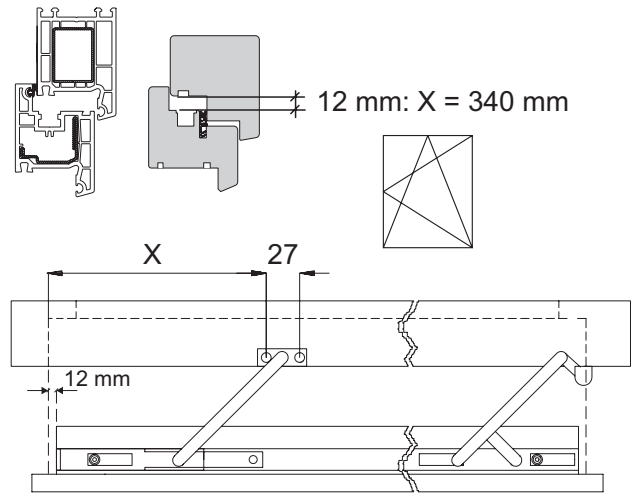
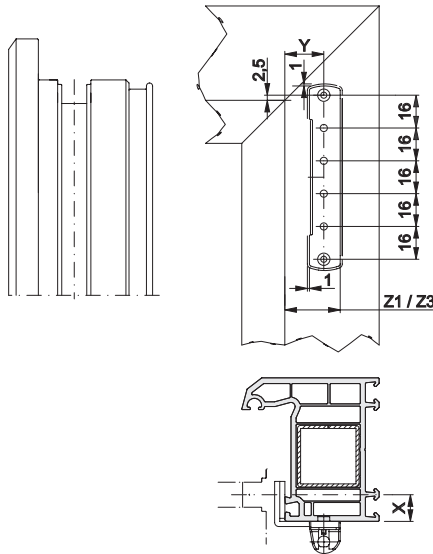

B-7-4: Installation drawing additional shear ZSR (X with regard to frame rebate edge)

SL.KB...

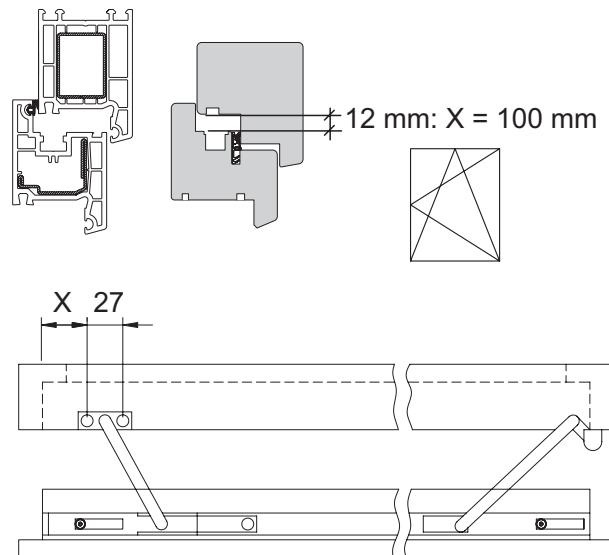
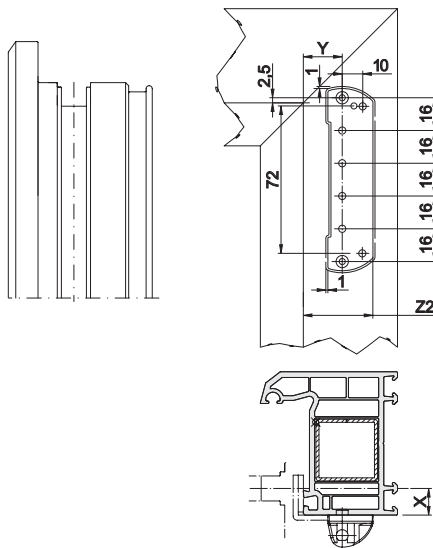

B-7-5: Installation drawing additional shear ZSRE (for fitting type "Tilt before turn")

	X	Y	SL.KS... Z1	SL.KB... Z2	SL.KS...130 Z3
SK... 20 - 9	9	19	27	34	29
SK... 20 - 13	13	19	27	34	29
SK... 21 - 13	13	20	28	35	30

- B-7-1: Drilling template shear hinge SL.KS. ...
- Drilling template shear hinge SL.KB. ...
- Drilling template shear hinge SL.K.3-6.130

Additional shear

Accessories

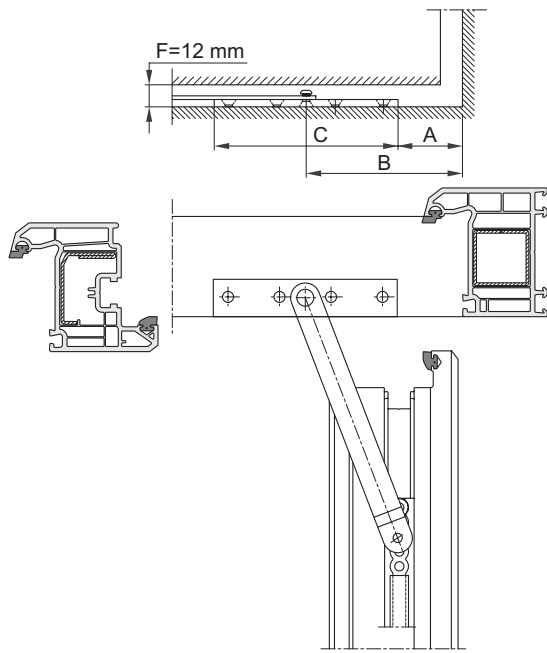

	A	B	C
DB 11	0	50	100
DB 11/1	85	135	100
DB 11-350	0	9	59

B-10-1: Drilling template turn limiter DB 11 ...
 F = airgap
 A = distance frame plate, lateral
 B = distance pivot point, lateral
 C = length frame plate

Opening limiter

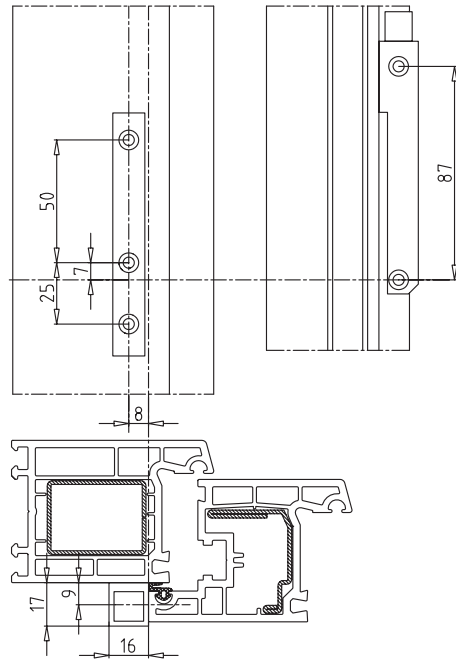

B-10-2: Drilling template opening limiter OBV

Rotation stop device DS

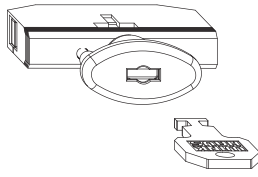

UEB* [mm]	X [mm]	Y [mm]
18	194	12
20	196	14
21	197	15
22	198	16

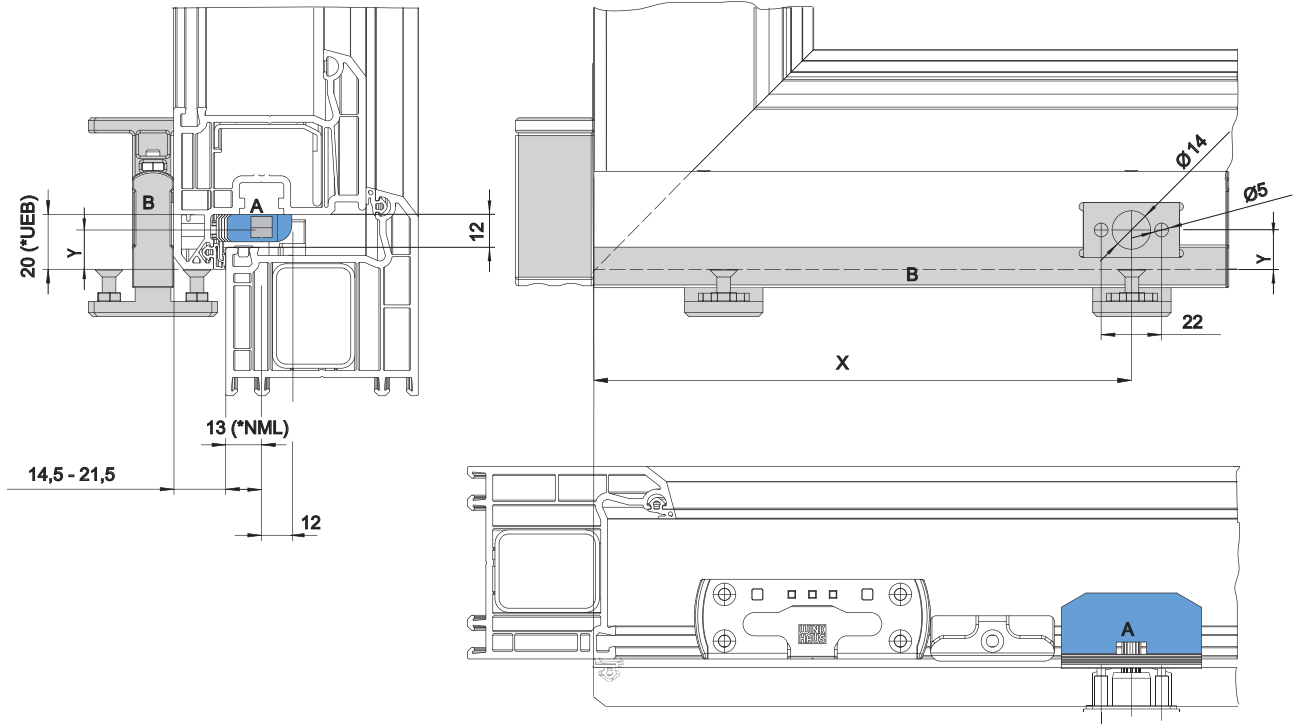

B-10-3: Drilling template window lock DS

- A = component of window lock DS
- B = Jig for window lock LE.DS
- UEB = overlap
- NML = groove centre position
- * = Example dimension

Aug. Winkhaus GmbH & Co. KG

August-Winkhaus-Straße 31
D-48291 Telgte
T +49 2504 921-0
F +49 2504 921-340

winkhaus.de
fenstertechnik@winkhaus.de